

SIEMENS

SITRANS L

Ultrasonic level transmitters SITRANS Probe LU240 with mA/HART

Operating Instructions

7ML51 (SITRANS Probe LU240)

Getting started	1
Introduction	2
Safety notes	3
Description	4
Installing/mounting	5
Connecting	6
Commissioning	7
Operating	8
Parameter assignment - Local	9
Parameter assignment - Remote	10
Service and maintenance	11
Diagnosing and troubleshooting	12
Technical data	13
Dimension drawings	14
Technical reference	A
HART communication	B
Remote operation	C
Certificates and support	D
HMI menu structure	E
Abbreviations	F

Legal information

Warning notice system

This manual contains notices you have to observe in order to ensure your personal safety, as well as to prevent damage to property. The notices referring to your personal safety are highlighted in the manual by a safety alert symbol, notices referring only to property damage have no safety alert symbol. These notices shown below are graded according to the degree of danger.

DANGER

indicates that death or severe personal injury **will** result if proper precautions are not taken.

WARNING

indicates that death or severe personal injury **may** result if proper precautions are not taken.

CAUTION

indicates that minor personal injury can result if proper precautions are not taken.

NOTICE

indicates that property damage can result if proper precautions are not taken.

If more than one degree of danger is present, the warning notice representing the highest degree of danger will be used. A notice warning of injury to persons with a safety alert symbol may also include a warning relating to property damage.

Qualified Personnel

The product/system described in this documentation may be operated only by **personnel qualified** for the specific task in accordance with the relevant documentation, in particular its warning notices and safety instructions. Qualified personnel are those who, based on their training and experience, are capable of identifying risks and avoiding potential hazards when working with these products/systems.

Proper use of Siemens products

Note the following:

WARNING

Siemens products may only be used for the applications described in the catalog and in the relevant technical documentation. If products and components from other manufacturers are used, these must be recommended or approved by Siemens. Proper transport, storage, installation, assembly, commissioning, operation and maintenance are required to ensure that the products operate safely and without any problems. The permissible ambient conditions must be complied with. The information in the relevant documentation must be observed.

Trademarks

All names identified by ® are registered trademarks of Siemens AG. The remaining trademarks in this publication may be trademarks whose use by third parties for their own purposes could violate the rights of the owner.

Disclaimer of Liability

We have reviewed the contents of this publication to ensure consistency with the hardware and software described. Since variance cannot be precluded entirely, we cannot guarantee full consistency. However, the information in this publication is reviewed regularly and any necessary corrections are included in subsequent editions.

Table of contents

1	Getting started	11
2	Introduction.....	13
2.1	Purpose of this documentation	13
2.2	Document history	13
2.3	FW revision history	13
2.4	Industrial use note.....	14
2.5	Product compatibility.....	14
2.6	Items supplied.....	14
2.7	Checking the consignment	15
2.8	Security information	15
2.9	Transportation and storage.....	16
2.10	Notes on warranty.....	16
3	Safety notes.....	17
3.1	Preconditions for use	17
3.1.1	Improper device modifications	17
3.1.2	Safety marking symbols.....	17
3.2	Laws and directives	18
3.2.1	Conformity with European directives	18
3.3	Requirements for special applications	19
3.4	Use in hazardous areas.....	19
4	Description.....	21
4.1	Overview SITRANS Probe LU240	21
4.2	Features	21
4.3	Applications.....	21
4.4	Approvals	22
4.5	System configuration	23
4.6	HART communication	23

5	Installing/mounting	25
5.1	Basic safety notes	25
5.1.1	Installation location requirements	26
5.1.1.1	Recommended	27
5.1.1.2	Avoid	28
5.1.2	Proper mounting	29
5.1.2.1	Process connections	29
5.2	Disassembly	30
6	Connecting	31
6.1	Basic safety notes	31
6.2	Connecting SITRANS Probe LU240	31
6.2.1	Wiring instructions	32
6.3	Hazardous area installations	34
6.3.1	Nameplates for hazardous area installations	35
6.3.1.1	Intrinsic safety wiring	35
6.3.1.2	Non-incendive wiring	36
6.3.2	Further information related to hazardous area installations	36
6.3.3	Instructions specific to hazardous area installations	36
6.3.3.1	Instructions in accordance with IEC 60079-0:2011 clause 30	36
7	Commissioning	39
7.1	Basic safety notes	39
7.2	Local commissioning	39
7.2.1	Activating SITRANS Probe LU240	40
7.2.2	Local display	40
7.2.2.1	Display symbols	41
7.2.2.2	Display views	41
7.2.2.3	Navigating in the views	44
7.2.2.4	Parameter menus	44
7.2.3	Programming	46
7.2.4	Wizards	47
7.2.4.1	Quick commissioning	47
7.2.4.2	AFES wizard	69
7.2.5	Requesting an echo profile	70
7.2.6	Device address	70
7.2.7	Testing the configuration	71
7.3	Application examples	71
7.3.1	Level application example	71
7.3.2	Volume flow application example	72
8	Operating	75
8.1	Operating instructions	75
8.1.1	Starting measurement	75
8.1.2	Measurement conditions	76
8.1.3	mA control	77
8.1.4	Volume	78
8.1.4.1	Vessel shape and dimensions	78

8.1.5	Volume flow	79
8.1.5.1	Flow calculation	79
8.1.5.2	Open Channel Monitoring (OCM)	80
8.1.6	Custom application	101
8.1.6.1	Characterization chart.....	101
8.1.7	Simulation	103
8.1.8	Communication system.....	107
9	Parameter assignment - Local.....	109
9.1	Quick start (M 01)	109
9.1.1	Quick commissioning (01-01)	109
9.1.2	AFES wizard (01-02).....	109
9.2	Setup (M 02)	110
9.2.1	Select output (M 02-01)	110
9.2.1.1	PV selection (02-01.01)	110
9.2.1.2	SV selection (02-01.02)	112
9.2.1.3	Linearization type (02-01.03)	112
9.2.2	Sensor (M 02-02)	112
9.2.2.1	Units (02-02.01)	112
9.2.2.2	Fill rate (02-02.02).....	113
9.2.2.3	Empty rate (02-02.03)	113
9.2.3	Calibration (M 02-03)	114
9.2.3.1	Auto sound velocity wizard (02-03.01).....	114
9.2.3.2	Sensor offset wizard (02-03.02).....	115
9.2.3.3	Lower calibration point (02-03.03)	116
9.2.3.4	Upper calibration point (02-03.04)	116
9.2.3.5	Lower level point (02-03.05)	116
9.2.3.6	Upper level point (02-03.06)	116
9.2.3.7	Sensor offset (02-03.07)	116
9.2.3.8	Sound velocity (02-03.08).....	117
9.2.3.9	Sound velocity (20 °C) (02-03.09)	117
9.2.3.10	Short shot frequency (02-03.10)	117
9.2.3.11	Long shot frequency (02-03.11).....	117
9.2.3.12	Low-level cutoff (02-03.12)	117
9.2.4	Current output (M 02-04)	118
9.2.4.1	Loop current mode (02-04.01)	118
9.2.4.2	Loop current value in multidrop mode (02-04.02).....	119
9.2.4.3	Damping value (02-04.03)	119
9.2.4.4	Lower range value (02-04.04).....	119
9.2.4.5	Upper range value (02-04.05).....	120
9.2.4.6	Lower saturation limit (02-04.06)	120
9.2.4.7	Upper saturation limit (02-04.07)	120
9.2.4.8	Lower fault current (02-04.08)	120
9.2.4.9	Upper fault current (02-04.09)	121
9.2.4.10	Fault current (02-04.10)	121
9.2.4.11	Fail-safe loss of echo (02-04.11)	121
9.2.4.12	Fail-safe LOE timer (02-04.12)	121
9.2.5	Volume (M 02-05)	121
9.2.5.1	Vessel shape (02-05.01).....	121
9.2.5.2	Vessel dimension A (02-05.02).....	123
9.2.5.3	Vessel dimension L (02-05.03)	123
9.2.5.4	Volume units (02-05.04).....	123

9.2.5.5	Upper scaling point (02-05.05).....	124
9.2.6	Volume flow (M 02-06).....	124
9.2.6.1	Primary measuring device (02-06.01).....	124
9.2.6.2	Method of flow calculation (02-06.02).....	125
9.2.6.3	Volume flow units (02-06.03).....	125
9.2.6.4	Upper scaling point (02-06.04).....	125
9.2.6.5	PMD dimensions (M 02-06-05).....	126
9.2.7	Custom (M 02-07).....	129
9.2.7.1	Upper scaling point (02-07.01).....	129
9.2.7.2	Customized characteristic curve (M 02-07.02).....	130
9.2.8	Local display (M 02-08).....	130
9.2.8.1	Start view (02-08.01).....	130
9.2.8.2	Service view (02-08.02).....	131
9.2.8.3	Display test wizard (02-08.03).....	131
9.3	Maintenance and diagnostics (M 03).....	132
9.3.1	Signal (M 03-01).....	132
9.3.1.1	Signal quality (M 03-01-01).....	132
9.3.1.2	Echo configuration (M 03-01-02).....	133
9.3.1.3	Echo select (M 03-01-03).....	133
9.3.1.4	Filtering (M 03-01-04).....	135
9.3.1.5	Sampling (M 03-01-05).....	137
9.3.1.6	TVT configuration (M 03-01-06).....	138
9.3.2	Peak values (M 03-02).....	140
9.3.2.1	Minimum PV (03-02.01).....	140
9.3.2.2	Maximum PV (03-02.02).....	140
9.3.2.3	Minimum distance (03-02.03).....	141
9.3.2.4	Maximum distance (03-02.04).....	141
9.3.2.5	Minimum sensor temperature (03-02.05).....	141
9.3.2.6	Maximum sensor temperature (03-02.06).....	141
9.3.3	Loop test (M 03-03).....	141
9.3.3.1	Loop test wizard (03-03.01).....	141
9.3.4	Resets (M 03-04).....	142
9.3.4.1	Device restart (03-04.01).....	142
9.3.4.2	Reset (03-04.02).....	142
9.3.4.3	Reset peak values (03-04.03).....	143
9.4	Communication (M 04).....	144
9.4.1	Polling address (04.01).....	144
9.4.2	Identify the device (04.02).....	144
9.5	Security (M 05).....	144
9.5.1	Change user PIN (05.01).....	144
9.5.2	Recovery ID (05.02).....	145
9.5.3	PIN recovery (05.03).....	145
9.5.4	User PIN (05.04).....	146
9.5.5	Button lock (05.05).....	146
10	Parameter assignment - Remote.....	147
10.1	Identification.....	147
10.1.1	Tag.....	147
10.1.2	Long tag.....	147
10.1.3	Descriptor.....	147
10.1.4	Message.....	147

10.1.5	Installation date	148
10.1.6	Device	148
10.1.6.1	Manufacturer	148
10.1.6.2	Product name	148
10.1.6.3	Protocol	148
10.1.6.4	Article number	148
10.1.6.5	Order option 1	148
10.1.6.6	Order option 2	148
10.1.6.7	Serial number	148
10.1.6.8	HW version	148
10.1.6.9	FW version	148
10.1.6.10	EDD version	149
10.1.6.11	Final assembly number	149
10.2	Setup	149
10.2.1	Custom units	150
10.3	Maintenance and diagnostics	150
10.3.1	Audit trail	150
10.3.1.1	Configuration change counter	150
10.4	Communication	151
10.4.1	Manufacturer's ID	151
10.4.2	HART expanded device type	151
10.4.3	Device ID	151
10.4.4	HART device revision	151
10.4.5	HART software revision	151
10.4.6	HART hardware revision	152
10.4.7	HART EDD revision	152
10.4.8	Universal command revision	152
10.4.9	Device profile code	152
10.4.10	Polling address	152
10.5	Security	152
10.6	Characteristics	153
10.6.1	Certificates and approvals	153
10.6.1.1	Intrinsic safety	153
10.6.1.2	Flameproof/Explosion proof	153
10.6.1.3	Increased safety	153
10.6.1.4	Protection by enclosure/Dust ignition proof	153
10.6.1.5	Non-sparking/Non-incendive	153
10.6.1.6	Protection by encapsulation	154
10.6.2	Sensor limits	154
10.6.2.1	Lower limit	154
10.6.2.2	Upper limit	154
10.6.2.3	Minimum measuring span	154
11	Service and maintenance	155
11.1	Basic safety notes	155
11.1.1	Steps for periodic inspection	155
11.2	Cleaning	156

11.3	Maintenance and repair work.....	156
11.3.1	Replacing the display.....	157
11.3.1.1	Remove existing display.....	157
11.3.1.2	Install a new display.....	158
11.3.2	Spare parts list.....	159
11.4	Return procedure.....	159
11.5	Disposal.....	160
12	Diagnosing and troubleshooting.....	161
12.1	Communication troubleshooting.....	161
12.2	Device status symbols.....	162
12.3	Device information symbols.....	165
12.4	Fault codes and corrective actions.....	165
12.5	Operation troubleshooting.....	172
12.5.1	Common problems.....	172
12.5.2	Noise problems.....	174
12.5.2.1	Determining the noise source.....	174
12.5.2.2	Other noise sources.....	174
12.5.2.3	Reducing electrical noise.....	174
12.5.2.4	Reducing acoustical noise.....	175
12.5.3	Measurement difficulties.....	175
12.5.3.1	Adjusting transducer aiming.....	175
12.5.3.2	Fixed reading.....	176
12.5.3.3	Obstructions in the sound beam.....	176
12.5.3.4	Nozzle mountings.....	176
12.5.3.5	Set the device to ignore the bad echo.....	176
12.5.4	Wrong reading.....	177
12.5.5	Transducer ringing.....	178
12.5.6	Echo profile display and Trend display.....	178
13	Technical data.....	179
13.1	Power.....	179
13.2	Performance.....	180
13.3	Interface.....	180
13.4	Outputs.....	181
13.5	Construction.....	181
13.6	Operating conditions.....	182
13.7	Process.....	182
13.8	Communication.....	182
13.9	Approvals.....	183
14	Dimension drawings.....	185
14.1	SITRANS Probe LU240 dimensions.....	185
14.2	Flange adaptor (optional).....	186

A	Technical reference	187
A.1	Principle of operation	187
A.1.1	Process values	187
A.1.2	Transmit pulse	187
A.2	Echo processing	188
A.2.1	Echo selection	189
A.2.1.1	TVT (time varying threshold) curves	189
A.2.1.2	Algorithm	189
A.2.1.3	Confidence	190
A.2.1.4	Echo threshold	190
A.2.1.5	Auto false echo suppression and Custom TVT	190
A.2.2	Measurement range	192
A.2.3	Measurement response	193
A.2.3.1	Damping	193
A.3	Current output	194
A.3.1	Fail-safe	195
A.4	Distance calculation	195
A.4.1	Sound velocity	196
A.5	Volume calculation	196
A.6	Volume flow calculation	198
A.6.1	Method of flow calculation	199
A.7	Chemical compatibility	200
A.8	Startup behavior	200
A.9	Loop power	200
A.10	Hazardous area installations	201
A.10.1	Intrinsically safe model	201
B	HART communication	205
B.1	Communication connections	206
B.2	Configuring communication ports	207
B.3	Communication troubleshooting	207
C	Remote operation	209
C.1	SIMATIC PDM	209
C.1.1	Initial setup	209
C.1.1.1	Deactivating buffers	209
C.1.2	Updating Electronic Device Description (EDD)	210
C.1.2.1	Configuring a new device	210
C.1.3	Changing parameter settings using SIMATIC PDM	211
C.1.4	Parameters via PDM structure view	212
C.1.5	Parameters and methods via PDM menus	212
C.1.5.1	Device menu	214
C.1.5.2	View menu	237
C.1.5.3	Diagnostics menu	238

C.2	AMS device manager.....	239
C.3	Field Communicator (FC) 375/475.....	240
C.4	FDT (Field Device Tool).....	241
D	Certificates and support	243
D.1	Certificates	243
D.2	Technical Support	243
D.3	QR code label	244
E	HMI menu structure	245
F	Abbreviations.....	249
	Glossary	251
	Index	255

Getting started

Introduction

Use this chapter as a quick reference. It provides links to the steps required for startup.

Before you begin, read the following safety information:

- General safety information (Page 17)
- Basic safety information: Installing/mounting (Page 25)
- Basic safety information: Connecting (Page 31)
- Basic safety information: Commissioning (Page 39)

Read the entire Operating Instructions to achieve optimum device performance.

Procedure

1. Install/mount the device.

Installation location requirements (Page 26)

2. Connect the device.

Connecting SITRANS Probe LU240 (Page 31)

3. Install (optional) display

Install a new display (Page 158)

4. Power up the device.

Activating SITRANS Probe LU240 (Page 40)

5. Commission the device via quick commissioning wizard:

Quick commissioning: Level/Space/Distance/Custom (Page 49)

Quick commissioning: Volume (Page 54)

Quick commissioning: Volume flow (Page 60)

Startup is complete.

Introduction

2.1 Purpose of this documentation

These instructions contain all information required to commission and use the device. Read the instructions carefully prior to installation and commissioning. In order to use the device correctly, first review its principle of operation.

The instructions are aimed at persons mechanically installing the device, connecting it electronically, configuring the parameters and commissioning it, as well as service and maintenance engineers.

2.2 Document history

The following table shows major changes in the documentation compared to the previous edition.

Edition	Note
10/2018	First edition

2.3 FW revision history

Sensor

Firmware revision	PDM EDD revision	Date	Changes
1.00.00	1.00.00	October 1, 2018	<ul style="list-style-type: none"> Initial release.

HMI

Firmware revision	Date	Changes
1.00.00	October 1, 2018	<ul style="list-style-type: none"> Initial release.

2.4 Industrial use note

NOTICE
Use in a domestic environment
This Class A Group 1 equipment is intended for use in industrial areas. In a domestic environment this device may cause radio interference.

2.5 Product compatibility

The following table describes compatibility between document edition, device revision, engineering system and associated Electronic Device Description (EDD).

Manual edition	Remarks	Device revision	Compatible version of device integration package	
10/2018	First edition	HART FW: 1.00.00 or later HW: 1.00.00 or later Device revision 1 or later	SIMATIC PDM V9.1	EDD: 1.00.00 or later
			AMS Device Manager V13.5	EDD: 1.00.00 or later
			SITRANS DTM V4.1 SP4	EDD: 1.00.00 or later
			Field communicator (FC) 375/475 V3.8	EDD: 1.00.00 or later
			SITRANS library	EDD: 1.00.00 or later

2.6 Items supplied

- SITRANS Probe LU240 ultrasonic level transmitter with HART communication

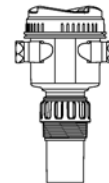

- Display (optional)



- Siemens Process Instrumentation documentation disk containing certificates, and manuals for ATEX approved devices



Note

Scope of delivery may vary, depending on version and add-ons. Make sure the scope of delivery and the information on the nameplate correspond to your order and the delivery note.

2.7 Checking the consignment

1. Check the packaging and the delivered items for visible damages.
2. Report any claims for damages immediately to the shipping company.
3. Retain damaged parts for clarification.
4. Check the scope of delivery by comparing your order to the shipping documents for correctness and completeness.

 WARNING
Using a damaged or incomplete device
Risk of explosion in hazardous areas.
<ul style="list-style-type: none">• Do not use damaged or incomplete devices.

2.8 Security information

Siemens provides products and solutions with industrial security functions that support the secure operation of plants, systems, machines, and networks.

In order to protect plants, systems, machines and networks against cyber threats, it is necessary to implement – and continuously maintain – a holistic, state-of-the-art industrial security concept. Siemens' products and solutions constitute one element of such a concept.

Customers are responsible for preventing unauthorized access to their plants, systems, machines and networks. Such systems, machines and components should only be connected to an enterprise network or the internet if and to the extent such a connection is necessary and only when appropriate security measures (e.g. firewalls and/or network segmentation) are in place.

For additional information on industrial security measures that may be implemented, please visit:

<https://www.siemens.com/industrialsecurity>

Siemens' products and solutions undergo continuous development to make them more secure. Siemens strongly recommends that product updates are applied as soon as they are available and that the latest product versions are used. Use of product versions that are no longer supported, and failure to apply the latest updates may increase customer's exposure to cyber threats.

To stay informed about product updates, subscribe to the Siemens Industrial Security RSS Feed under

<https://www.siemens.com/industrialsecurity>.

2.9 Transportation and storage

To guarantee sufficient protection during transport and storage, observe the following:

- Keep the original packaging for subsequent transportation.
- Devices/replacement parts should be returned in their original packaging.
- If the original packaging is no longer available, ensure that all shipments are properly packaged to provide sufficient protection during transport. Siemens cannot assume liability for any costs associated with transportation damages.

NOTICE
Insufficient protection during storage
The packaging only provides limited protection against moisture and infiltration.
<ul style="list-style-type: none">• Provide additional packaging as necessary.

Special conditions for storage and transportation of the device are listed in Operating conditions (Page 182).

2.10 Notes on warranty

The contents of this manual shall not become part of or modify any prior or existing agreement, commitment or legal relationship. The sales contract contains all obligations on the part of Siemens as well as the complete and solely applicable warranty conditions. Any statements regarding device versions described in the manual do not create new warranties or modify the existing warranty.

The content reflects the technical status at the time of publishing. Siemens reserves the right to make technical changes in the course of further development.

Safety notes

3.1 Preconditions for use



This device left the factory in good working condition. In order to maintain this status and to ensure safe operation of the device, observe these instructions and all the specifications relevant to safety.

Observe the information and symbols on the device. Do not remove any information or symbols from the device. Always keep the information and symbols in a completely legible state.

3.1.1 Improper device modifications

 WARNING
<p>Improper device modifications</p> <p>Risk to personnel, system and environment can result from modifications to the device, particularly in hazardous areas.</p> <ul style="list-style-type: none"> • Only carry out modifications that are described in the instructions for the device. Failure to observe this requirement cancels the manufacturer's warranty and the product approvals.

3.1.2 Safety marking symbols

In manual	On product	Description
		WARNING: refer to accompanying documents (manual) for details.
		Dispose of in an environmentally safe manner, and according to local regulations.

3.2 Laws and directives

Observe the test certification, provisions and laws applicable in your country during connection, assembly and operation. These include, for example:

- National Electrical Code (NEC - NFPA 70) (USA)
- Canadian Electrical Code (CEC) (Canada)

Further provisions for hazardous area applications are for example:

- IEC 60079-14 (international)
- EN 60079-14 (EU)
- For Korea only:

이 기기는 업무용(A 급) 전자파 적합기기로서 판매자 또는 사용자는 이 점을 주의하시기 바라며 가정 외의 지역에서 사용하는 것을 목적으로 합니다

3.2.1 Conformity with European directives

The CE marking on the device symbolizes the conformity with the following European directives:

Electromagnetic compatibility EMC 2014/30/EU	Directive of the European Parliament and of the Council on the harmonisation of the laws of the Member States relating to electromagnetic compatibility
Low voltage directive LVD 2014/35/EU	Directive of the European Parliament and of the Council on the harmonisation of the laws of the Member States relating to the making available on the market of electrical equipment designed for use within certain voltage limits
Atmosphère explosible ATEX 2014/34/EU	Directive of the European Parliament and the Council on the harmonisation of the laws of the Member States relating to equipment and protective systems intended for use in potentially explosive atmospheres
2011/65/EU RoHS	Directive of the European Parliament and the Council on the restriction of the use of certain hazardous substances in electrical and electronic equipment

The applicable directives can be found in the EU declaration of conformity of the specific device.

3.3 Requirements for special applications

Due to the large number of possible applications, each detail of the described device versions for each possible scenario during commissioning, operation, maintenance or operation in systems cannot be considered in the instructions. If you need additional information not covered by these instructions, contact your local Siemens office or company representative.

Note

Operation under special ambient conditions

We highly recommend that you contact your Siemens representative or our application department before you operate the device under special ambient conditions as can be encountered in nuclear power plants or when the device is used for research and development purposes.

Note

Operation under special atmospheric conditions

Ultrasonic measurement requires that the sound wave travel through the atmosphere in a consistent manner. Applications with atmospheric conditions different from air (including, but not limited to, gas layer stratification, very high methane or CO₂ concentrations), should be properly assessed to ensure safe, reliable use in the event of measurement errors due to sound wave velocity changes.

3.4 Use in hazardous areas

Qualified personnel for hazardous area applications

Persons who install, connect, commission, operate, and service the device in a hazardous area must have the following specific qualifications:

- They are authorized, trained or instructed in operating and maintaining devices and systems according to the safety regulations for electrical circuits, high pressures, aggressive, and hazardous media.
- They are authorized, trained, or instructed in carrying out work on electrical circuits for hazardous systems.
- They are trained or instructed in maintenance and use of appropriate safety equipment according to the pertinent safety regulations.

 **WARNING**

Use in hazardous area

Risk of explosion.

- Only use equipment that is approved for use in the intended hazardous area and labelled accordingly.
- Don't use devices that have been operated outside the conditions specified for hazardous areas. If you have used the device outside the conditions for hazardous areas permanently make all Ex markings unrecognizable on the nameplate.

 **WARNING**

Loss of safety of device with type of protection "Intrinsic safety Ex i"

If the device or its components have already been operated in non-intrinsically safe circuits or the electrical specifications have not been observed, the safety of the device is no longer ensured for use in hazardous areas. There is a risk of explosion.

- Connect the device with type of protection "Intrinsic safety" solely to an intrinsically safe circuit.
- Observe the specifications for the electrical data on the certificate and/or in Technical data (Page 179).

Description

4.1 Overview SITRANS Probe LU240

SITRANS Probe LU240 ultrasonic level transmitter with HART, 4 to 20 mA is ideal for level, volume, and volume flow measurements. It works with liquids, slurries, and bulk materials up to 12 meters (40 feet).

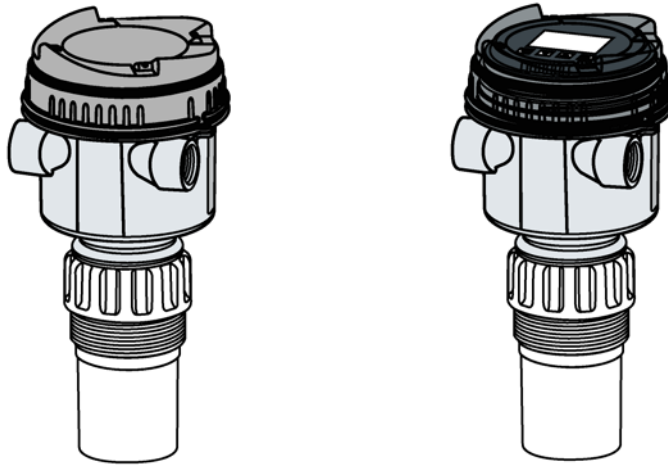

4.2 Features

The transducer is available as ETFE (ethylene-tetrafluoroethylene) or PVDF (polyvinylidene fluoride) to suit the chemical conditions of your application. For applications with varying temperatures, the SITRANS Probe LU240 incorporates an internal temperature sensor to compensate for temperature changes.

The self-cleaning face of SITRANS Probe LU240 is resistant to build-up and condensation and has field-proven Process Intelligence signal processing. Together, they provide long term, low maintenance level, volume, and volume flow measurement in difficult applications.

4.3 Applications

SITRANS Probe LU240 is designed to measure **Level**, **Volume**, or **Volume flow** in a variety of applications:

Level

- Storage type vessels
- Simple process vessels with some surface agitation
- Liquids
- Slurries
- Bulk solids
- Open channels

Volume

Pre-defined vessel shapes can be used to convert level measurements to volume.

Volume flow

For an open channel system (such as a Parshall flume, V-notch weir, or other open channel device), volume flow can be measured by using integral pre-defined flow structures.

Custom level to output

A customized level-to-output linearization function is available to calculate volume or volume flow, for vessels not included in the pre-defined shapes as noted above.

4.4 Approvals

SITRANS Probe LU240 is available with approvals for General purpose and Intrinsic safety for hazardous area installations.

In all cases, check the device nameplate and confirm the approval rating.

Note

Full list of approvals

For more information see Approvals (Page 183).

4.5 System configuration

Typical PLC/mA configuration

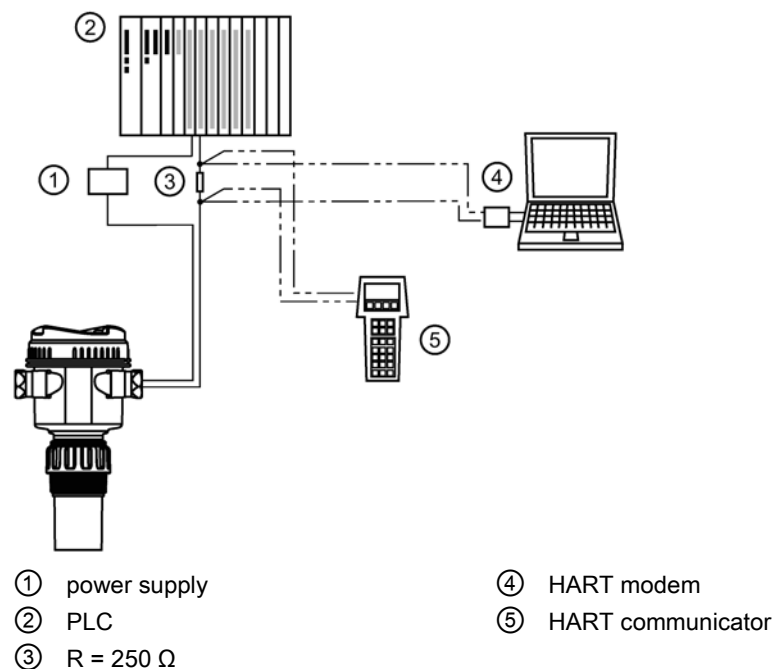

4.6 HART communication

This device supports HART communication protocol. For more information, see HART communication (Page 205).

Description

4.6 HART communication

Installing/mounting

5.1 Basic safety notes

 CAUTION
Hot surfaces resulting from hot process media Risk of burns resulting from surface temperatures above 65 °C (149 °F). <ul style="list-style-type: none">• Take appropriate protective measures, for example contact protection.• Make sure that protective measures do not cause the maximum permissible ambient temperature to be exceeded. Refer to the information in Technical data (Page 179).

 WARNING
Wetted parts unsuitable for the process media Risk of injury or damage to device. Hot, toxic and corrosive media could be released if the process medium is unsuitable for the wetted parts. <ul style="list-style-type: none">• Ensure that the material of the device parts wetted by the process medium is suitable for the medium. Refer to the information in Technical data (Page 179).

Note

Material compatibility

Siemens can provide you with support concerning selection of sensor components wetted by process media. However, you are responsible for the selection of components. Siemens accepts no liability for faults or failures resulting from incompatible materials.

 WARNING
Unsuitable connecting parts Risk of injury or poisoning. In case of improper mounting, hot, toxic, and corrosive process media could be released at the connections. <ul style="list-style-type: none">• Ensure that connecting parts (such as flange gaskets and bolts) are suitable for connection and process media.

 WARNING
Exceeded maximum permissible operating pressure Risk of injury or poisoning. The maximum permissible operating pressure depends on the device version, pressure limit and temperature rating. The device can be damaged if the operating pressure is exceeded. Hot, toxic and corrosive process media could be released. Ensure that maximum permissible operating pressure of the device is not exceeded. Refer to the information on the nameplate and/or in Technical data (Page 179).

 CAUTION
External stresses and loads Damage to device by severe external stresses and loads (e.g. thermal expansion or pipe tension). Process media can be released. <ul style="list-style-type: none">• Prevent severe external stresses and loads from acting on the device.

5.1.1 Installation location requirements

NOTICE
Strong vibrations Damage to device. <ul style="list-style-type: none">• In installations with strong vibrations, mount the transmitter in a low vibration environment.

 CAUTION
Aggressive atmospheres Damage to device through penetration of aggressive vapors. <ul style="list-style-type: none">• Ensure that the device is suitable for the application.

 **CAUTION**

Direct sunlight

Device damage.

The device can overheat or materials become brittle due to UV exposure.

- Protect the device from direct sunlight.
- Make sure that the maximum permissible ambient temperature is not exceeded. Refer to the information in Technical data (Page 179).

NOTICE

Mounting location

- Ideally, mount device so that face of transducer is at least 300 mm (1 ft) above the highest anticipated material level.

5.1.1.1

Recommended

- Ambient temperature within -40 to $+80$ °C (-40 to $+176$ °F)
- Process temperature within -40 to $+85$ °C (-40 to $+185$ °F)
- Environment suitable to the housing rating and materials of construction
- Sound path perpendicular to the material surface
- Display and local buttons easily accessible for programming
- Cable entries easily accessible for wiring
- Sufficient room to open device lid with clear access
- Mounting surface free from vibration
- Place for a laptop computer provided for on-site configuration (optional, as laptop not required for configuration)

NOTICE

Device rotation

The device can be rotated separate from the process connection.

- There is no limit to the number of times device can be rotated without damage.

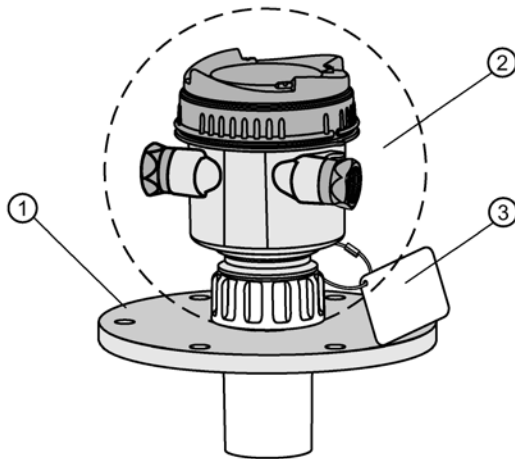

- ① Customer-supplied flange
- ② Ambient temperature surrounding enclosure -40 to $+80$ °C (-40 to $+176$ °F)
- ③ Device tag (optional)

5.1.1.2 Avoid

- Proximity to high voltage or current wiring, high voltage or current contacts, and to variable frequency motor speed controllers
- Exposure to direct sunlight. (Provide a sun shield to avoid direct sunlight.)
- Interference to sound path from obstructions (such as rough walls, seams, rungs, etc.), or from fill path

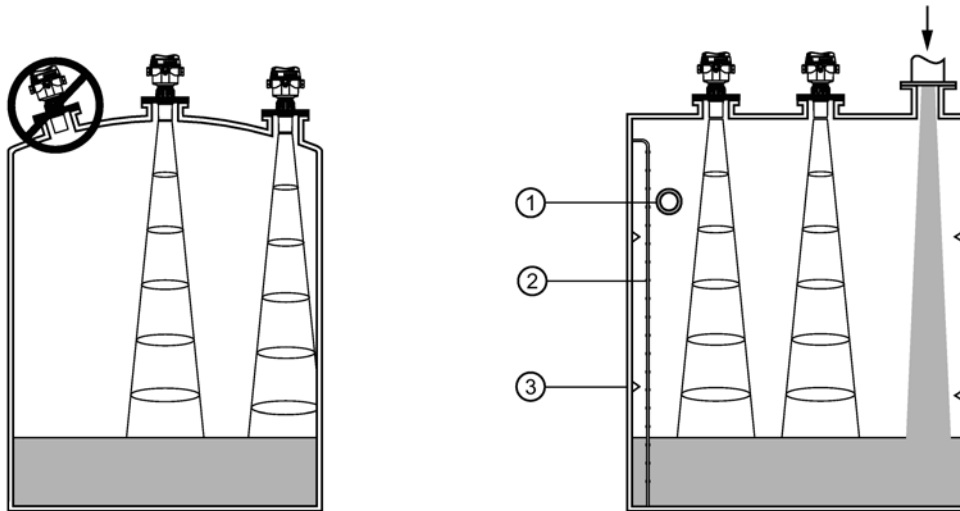

- ① Pipe
- ② Rungs
- ③ Seams

5.1.2 Proper mounting

NOTICE
Incorrect mounting The device can be damaged, destroyed, or its functionality impaired through improper mounting. <ul style="list-style-type: none">• Before installing ensure there is no visible damage to the device.• Make sure that process connectors are clean, and suitable gaskets and glands are used.• Mount the device using suitable tools. Refer to the information in Technical data (Page 179).

5.1.2.1 Process connections

Process connections are available with three thread types:

- 2" NPT [(Taper), ASME B1.20.1]
- R 2" [(BSPT), EN 10226]
- G 2" [(BSPP), EN ISO 228-1]

NOTICE
Process connection type The thread type can be found on the device process connection, defined by a letter in the mold, near the end of the threads.

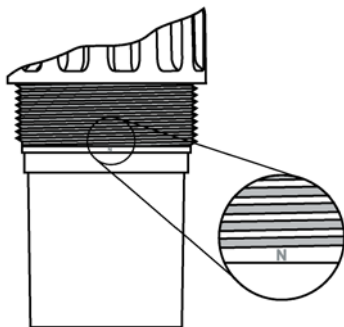

N=NPT

B=R2/BSPT

P=G2/BSPP/PF2

1. Before inserting device into its mounting connection, ensure threads are of the same type to avoid damaging them.
2. Screw device into process connection and hand tighten, or use a strap wrench to seat gasket if required (1/4 turn past hand tight is recommended).

5.2 Disassembly

 **WARNING**

Incorrect disassembly

The following risks may result from incorrect disassembly:

- Injury through electric shock
- Risk through emerging media when connected to the process
- Risk of explosion in hazardous area

In order to disassemble correctly, observe the following:

- Before starting work, make sure that you have switched off all physical variables such as pressure, temperature, electricity etc. or that they have a harmless value.
- If the device contains hazardous media, it must be emptied prior to disassembly. Make sure that no environmentally hazardous media are released.
- Secure the remaining connections so that no damage can result if the process is started unintentionally.

Connecting

6.1 Basic safety notes

NOTICE
Condensation in the device Damage to device through formation of condensation if the temperature difference between transportation or storage and the mounting location exceeds 20 °C (36 °F). <ul style="list-style-type: none">• Before taking the device into operation let the device adapt for several hours in the new environment.

 WARNING
Connecting device in energized state Risk of explosion in hazardous areas. <ul style="list-style-type: none">• Connect devices in hazardous areas only in a de-energized state.

6.2 Connecting SITRANS Probe LU240

 WARNING
Incorrect connection to power source Risk to personnel, system and environment can result from improper power connection. <ul style="list-style-type: none">• The DC input terminals shall be supplied from a source providing electrical isolation between the input and output, in order to meet the applicable safety requirements of IEC 61010-1. For example, SELV source.• All field wiring must have insulation suitable for rated voltages.

 **WARNING**

Loss of protection

Loss of approvals can result from improper connection.

- Check the nameplate on your device, to verify the approval rating.
- Use approved cable gland/conduit seal to maintain TYPE 4X, TYPE 6, IP66, IP68 ratings.
- See Hazardous area installations (Page 34).

Note

Considerations for connecting device

- Use shielded, twisted pair cable (wire gauge AWG 22 to AWG 14/ 0.34 mm² to 2.08 mm²).
 - Separate cables and conduits may be required to conform to standard instrumentation wiring practices, or electrical codes.
 - If cable is routed through conduit, use only approved suitable-size hubs for waterproof applications.
 - Non-metallic enclosure does not provide a continuous ground path between conduit connections: use grounding-type bushings and jumpers.
 - More detailed information can be found on Hazardous area installations (Page 201).
-

6.2.1 Wiring instructions

Note

Initial connection

The display is not connected to the device when shipped. If this is not initial connection, remove the display before wiring. See Remove existing display (Page 157).

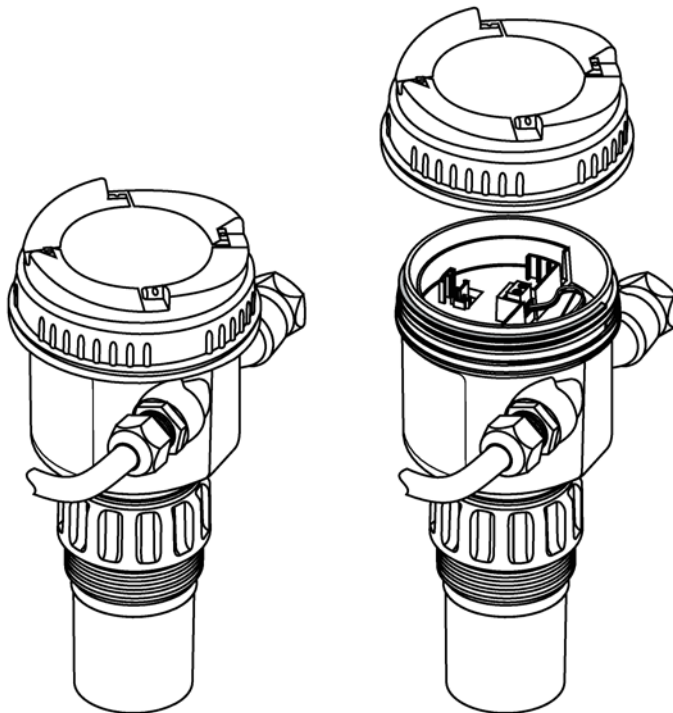

1. Turn lid by hand in a counter-clockwise direction to remove it from device.
2. Strip cable jacket for approximately 70 mm (2.75") from end of cable, and thread wires through gland.

3. Connect wires to terminals as shown below: polarity is identified on terminal block.

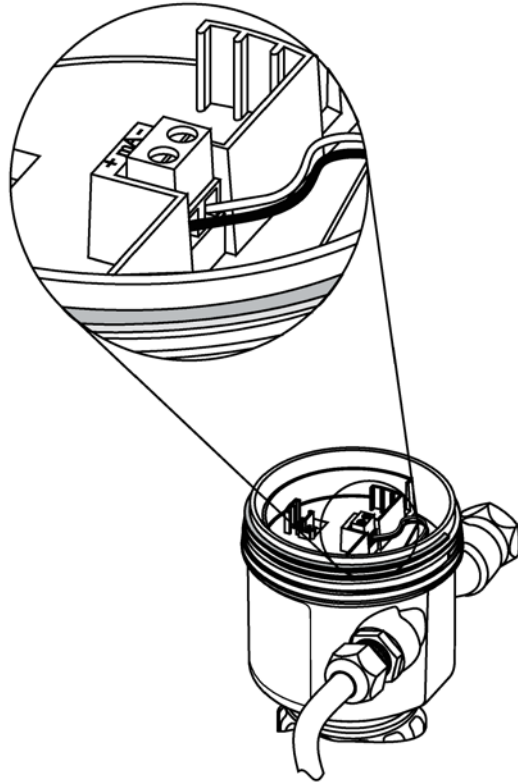

4. Tighten gland to form a good seal.
5. Press female end of cable from optional display onto male four-pin connector. See Install a new display (Page 158) for illustration.
6. Set optional display into enclosure. Buttons on display should sit over terminal block. Gently turn display a quarter turn clockwise to secure the display in the enclosure.
7. Replace device lid. Thread onto enclosure, turning clockwise. Hand tighten.

6.3 Hazardous area installations

⚠ WARNING

Improper power supply

Risk of explosion in hazardous areas as result of incorrect power supply.

- Connect the device in accordance with the specified power supply and signal circuits. The relevant specifications can be found in the certificates, in Technical data (Page 179) or on the nameplate.

6.3.1 Nameplates for hazardous area installations

6.3.1.1 Intrinsic safety wiring

Device nameplate (ATEX/IECEX/INMETRO/RCM)

Note

Sample nameplate

This nameplate is given as an example only.

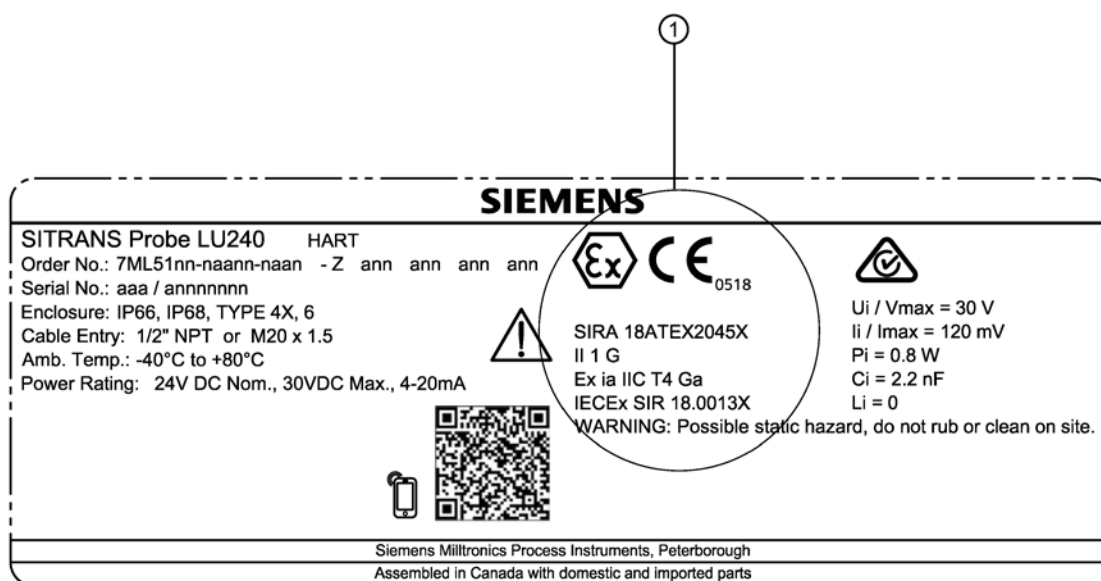

① ATEX certificate

The ATEX certificate number (SIRA 18ATEX2045X) listed on the nameplate can be downloaded from our website:

Product page (www.siemens.com/sitransprobelu240)

Go to **Support > Approvals/Certificates**.

The IECEx certificate listed on the nameplate can be viewed on the IECEx website:

<http://iecex.iec.ch> (<http://iecex.iec.ch>)

Under the "Certified Equipment" tab in the "Certificate/ExTR/QAR number" field, enter the IECEx SIR number:18.0013X.

For more information on hazardous area installations, refer to Instructions specific to hazardous area installations (Page 36).

Connection drawing (FM/CSA)

The FM/CSA connection drawing number (A5E44090649A) listed on the device nameplate can be downloaded from our website:

Product page (www.siemens.com/sitransprobelu240)

Go to **Technical Info > Images, graphics, drawings**.

6.3.1.2 Non-incendive wiring

Connection drawing (FM)

The FM connection drawing number (A5E44092290) listed on the device nameplate can be downloaded from our website:

Product page (www.siemens.com/sitransprobelu240)

Go to **Technical info > Images, graphics, drawings**.

6.3.2 Further information related to hazardous area installations



- For power demands see Loop power (Page 200).
- For wiring requirements follow local regulations.
- Use approved cable gland/conduit seal to maintain Type 4X, Type 6, IP66, IP68 ratings.
- For hazardous area approvals, see Approvals (Page 183).

6.3.3 Instructions specific to hazardous area installations

6.3.3.1 Instructions in accordance with IEC 60079-0:2011 clause 30

The following instructions relevant to safe use in a hazardous area apply to equipment covered by certificate numbers Sira 18ATEX2045X and IECEx SIR 18.0013X.

1. The certification marking is as follows:

Certificate number:	IECEx SIR 18.0013X	Sira 18ATEX2045X
Certification code:	Ex ia IIC T4 Ga	Ex ia IIC T4 Ga
Other marking:		 

2. The equipment may be used in zones 0, 1 & 2 with flammable gases and vapours with apparatus groups IIA, IIB & IIC and with temperature classes T4.
3. The equipment is only certified for use in ambient temperatures in the range -40 °C to +80 °C and should not be used outside this range.

4. Installation shall be carried out in accordance with the applicable code of practice by suitably-trained personnel.
5. There are no special checking or maintenance conditions other than a periodic check.
6. With regard to explosion safety, it is not necessary to check for correct operation.
7. The equipment contains no user-replaceable parts and is not intended to be repaired by the user. Repair of the equipment is to be carried out by the manufacturer, or their approved agents, in accordance with the applicable code of practice.
8. Repair of this equipment shall be carried out in accordance with the applicable code of practice.
9. If the equipment is likely to come into contact with aggressive substances, e.g. acidic liquids or gases that may attack metals or solvents that may affect polymeric materials, then it is the responsibility of the user to take suitable precautions that prevent it from being adversely affected thus ensuring that the type of protection is not compromised.
10. The certificate number has an 'X' suffix which indicates that special conditions of installation and use apply. Those installing or inspecting this equipment must have access to the contents of the certificate or these instructions. The conditions listed in the certificate are reproduced below:
 - Under certain extreme circumstances, the non-metallic parts incorporated in the enclosure of this equipment may generate an ignition-capable level of electrostatic charge. Therefore the equipment shall not be installed in a location where the external conditions are conducive to the build-up of electrostatic charge on such surfaces.
 - In addition, the equipment shall only be cleaned with a damp cloth. This is particularly important if the equipment is installed in a zone 0 location.

Commissioning

7.1 Basic safety notes

<p>! WARNING</p> <p>Loss of explosion protection</p> <p>Risk of explosion when device is not properly commissioned</p> <p>If opening device</p> <ul style="list-style-type: none"> • Isolate from power. <p>- or -</p> <ul style="list-style-type: none"> • Ensure that the atmosphere is explosion-free (hot work permit). <p>Ensure device is properly closed before returning to operation.</p>
--

7.2 Local commissioning

SITRANS Probe LU240 can be quickly commissioned using wizards, and menu driven parameters. The parameters can be modified locally using the device display and buttons, also known as the Human Machine Interface (HMI).

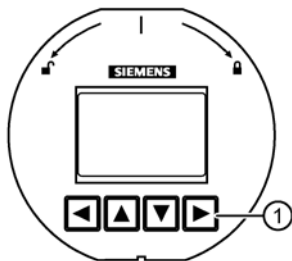

① Local device buttons

The quick start wizards provide an easy step-by-step procedure to help you configure the device for a simple application. We recommend that you configure your application in the following order:

- First, run the "Quick commissioning wizard" for your application (Level/Space/Distance/Custom, Volume, Volume flow).
- Next, run the "Auto false echo suppression wizard" (optional) to prevent false echo detection.
- After completing the wizards, configure any custom parameters via the parameter menus.
- Lastly, if desired, configure alarms and warnings using "Limit monitoring and event counter" via a remote engineering system.

There are two ways to access the quick commissioning wizards:

- Locally via HMI (see Quick commissioning (Page 47))
- From a remote location (see Quick commissioning wizards (Page 47))

See Level application example (Page 71), or Volume flow application example (Page 72) for illustrations, and for the complete range of parameters, see Parameter assignment - Local (Page 109) and Parameter assignment - Remote (Page 147).

7.2.1 Activating SITRANS Probe LU240

Power up the device.

SITRANS Probe LU240 runs through an initialization routine for approximately three seconds. Next, the device name and then firmware revision appear. The display goes into **measurement view** (measured process values show as "- - - -" before the first measurement is completed). The "Distance" measurement (displayed in meters) appears first by default. Press ▼ button to scroll through other values in **measurement view**.

The device is now ready for operation.

7.2.2 Local display

Note

Low temperature affects local display

The operating temperature of the display is -25 °C to +85 °C; -40 °C to +85 °C with reduced readability.

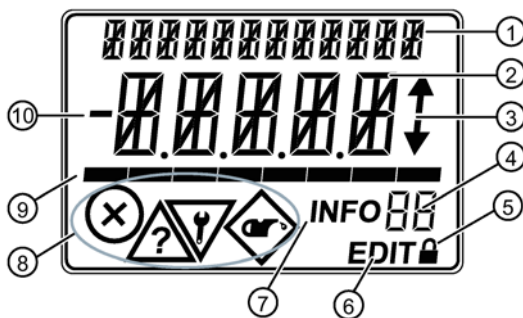

- | | |
|-----------------------------|-----------------------------|
| ① Title line | ⑥ EDIT indicator |
| ② Main line | ⑦ INFO indicator |
| ③ UP/DOWN navigation arrows | ⑧ NE107 diagnostic states |
| ④ Info field | ⑨ Bar graph |
| ⑤ Lock symbol | ⑩ Sign of the process value |

7.2.2.1 Display symbols

INFO field	Symbol	Meaning
LP	🔒	Device is write-protected via parameter "User PIN".
LL		Device is write-protected via parameter "Button lock".
Co		Loop test is running.
	EDIT	When symbol is flashing, you can edit the parameter.
	INFO	Diagnostic message. The ID next to the "INFO" symbol is used for identification of the diagnostic message.

For more information on diagnostic messages, see Fault codes and corrective actions (Page 165).

7.2.2.2 Display views

Note

Display views

- **Edit view** and **measurement view** refer to the display only. While the device is in **edit view**, the output remains active and continues to respond to changes in the device.
- The display will return to **measurement view** after ten minutes of inactivity (from last button press), when in **edit view** and from within a wizard. Pressing ► button will then take you to the main navigation menu. (It will not return to the screen from which the timeout occurred.)

Measurement view shows the current measured values of the device as well as status and diagnostic messages.

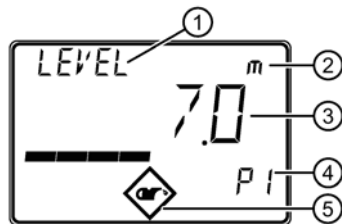

- ① Process value name
- ② Process value unit
(① and ② alternate on display)
- ③ Process value measurement
If the process value is too large to be shown on the display (value has more than 5 digits), hashes "#####" will be shown instead.
- ④ Process value number
- ⑤ Diagnostic symbol

Parameter view shows the parameters, parameter values and the wizards of the device.

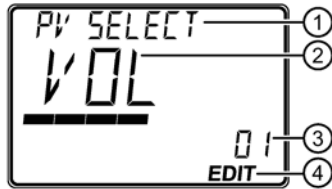

- ① Parameter name
- ② Parameter value
- ③ Parameter number
- ④ "EDIT" symbol (permanently enabled)

Edit view

Change parameter values in this view. Wizards are available for specific parameters.

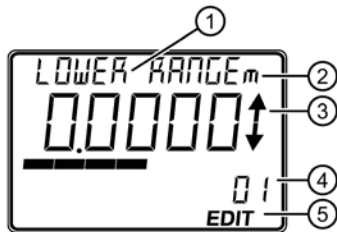

- ① Parameter name
- ② Process value unit (① and ② alternate on display)
- ③ Scrolling arrows (within options list only)
- ④ Parameter number
- ⑤ "EDIT" symbol (flashing)

Service view

Sets operation of local device display to show menu numbers in **parameter view**.



- ① Menu number
- Parameter name (top left), parameter unit (if available, top right), and menu number (as shown above, top left) alternate in two-second intervals.

Note

Show menu numbers on local display

To view menu numbers on the device, parameter "Service view" must be enabled. (Go to menu "**Setup > Local display**".)

- The item number of the current selection appears in the **info field**.
- The menu number in which the current selection resides, appears on the **title line** (thus no menu numbers appear for top-level menu items, such as "QUICK START", "SETUP", etc.).

Refer to full device menu in **HMI menu structure**.

Note

Dynamic decimal places

Each setting for parameter "Units" has a default number of decimal places used to show the process value on the local display. However, if the value is too large to show on the segment display, the decimal places will be automatically adjusted to show the process value.

Note



Process value too large to display

In some cases, even with dynamic decimal places, it is possible that the process value be too large to show on the local display, "#####" will show instead.

To correct, adjust parameter "Units" or "Custom units", depending on your application.

(Note that custom units can only be defined via remote operation, and if custom units are adjusted, rescaling of output is also required.)

7.2.2.3 Navigating in the views

<p>Measurement view</p> 	<p>After initialization, the display will be in measurement view.</p> <ol style="list-style-type: none"> 1. Select the desired measurement value using ▲ and ▼ buttons. 2. Navigate to parameter view using ► button. 3. Return to measurement view using ◀ button.
<p>Parameter view</p> 	<p>The "EDIT" symbol is not flashing.</p> <ol style="list-style-type: none"> 1. Select a parameter using ▲ and ▼ buttons. 2. Navigate to edit view using ► button. 3. Return to measurement view using ◀ button.
<p>Edit view</p> 	<p>The "EDIT" symbol is flashing.</p> <ol style="list-style-type: none"> 1. Change the parameter value using ▲ and ▼ buttons. 2. Accept a selected parameter value using ► button. 3. Return to measurement view using ◀ button.

7.2.2.4 Parameter menus

Note

Complete parameter list

For a complete list of parameters with instructions, see Parameter assignment - Local (Page 109) and Parameter assignment - Remote (Page 147).

Parameters are identified by name and organized into function groups, then arranged in a three-level menu structure.

On the local display:

- Navigate to a menu - menu name shows on **title line**, and "MENU" shows on **main line**. (**Info field** shows number of current selection within menu structure.)
- Navigate to a wizard - wizard name shows on **title line**, and "WIZ" shows on **main line**. (**Info field** shows number of current selection within menu structure.)
- Navigate to a parameter - parameter name shows on **title line**, and parameter number shows in **info field**.

Note

Items numbers may not appear sequentially

Although item numbers are sequential, they may not appear so as some menus and parameters are only visible on the device based on configuration settings.

For a full device menu see HMI menu structure (Page 245).

The three-level menu structure explained below is for the purpose of documenting, thus item numbers do not match exactly to the local display:

- For items that show "MENU" on device, this equates to "M" in documented menu structure below.
- For items that show "WIZ" on device, this equates to "W" in documented menu structure below.
- Menu and wizard numbers in the three-level structure are separated by dashes for each level (e.g. M 02-01 SELECT OUT).
- Parameter IDs are a combination of menu number and parameter number, where parameter number follows the dot (e.g. 02-01.01 PV SELECT).
- Wizard steps do not include the menu number (e.g. .01 OPERATION).

M 01 QUICK START

W 01-01 COMMISSION

.01 OPERATION

...

M 02 SETUP

M 02-01 SELECT OUT

02-01.01 PV SELECT

...

M 03 MAINT/DIAGS

M 03-01 SIGNAL





M 03-01-01 SIG QUALITY

M 03-01-01.01 SHRTSHOTCONF





7.2.3 Programming

From **measurement view**, press  button to enter **parameter view** and open the first menu level **M 01**.



To select a listed option:

1. Navigate to the desired parameter.
2. Press  button to open **edit view**. The current selection is highlighted.
3. Scroll to a new selection using  and  buttons.
4. Press  button to accept it. The display returns to **parameter view** and shows the new selection.

To change a numeric value:

1. Navigate to the desired parameter.
2. When selected, the current value is displayed.
3. Press  button to configure it. The "EDIT" symbol is flashing.
4. Use  and  buttons to increase or decrease the value. Press and hold button to increase scrolling speed.
5. To escape without saving your changes, press  button to return to **parameter view**.
6. Press  button to accept the new value. The display returns to **parameter view** ("EDIT" symbol is no longer flashing) and shows the new selection. Review for accuracy.

Button functions for editing

Button	Name		Function
	UP or DOWN arrow	Selecting parameter settings	Scrolls to item
		Alpha-numeric editing	Increases or decreases value. Pressing and holding will increase scrolling speed through values.
	RIGHT arrow	Selecting parameters	Accepts the data (writes the parameter setting)
	LEFT arrow	Selecting parameter settings	Cancels edit view without changing the parameter setting.

7.2.4 Wizards

7.2.4.1 Quick commissioning

Quick commissioning wizards

A wizard provides an easy step-by-step procedure that configures the device for a simple application. To configure the SITRANS Probe LU240 for applications of level, space, distance, volume, or volume flow, use the "Quick commissioning wizard" via HMI. It is possible to configure custom applications employing more complex vessel shapes via the HMI, but we suggest using a remote engineering system, such as SIMATIC PDM.



Quick commissioning wizards are also available remotely using various software packages:

- SIMATIC PDM (Page 209)
- Field Communicator (FC) 375/475 (Page 240)
- FDT (Field Device Tool) (Page 241)
- AMS device manager (Page 239)

Quick commissioning wizard

The SITRANS Probe LU240 provides a single quick commissioning wizard that can be used for various applications.

The initial wizard steps are common for all application types. Subsequent wizard parameters will vary depending on the application you choose. For the purpose of documenting, three separate lists follow. These lists include the wizard parameters available to commission each application type (see links below).

1. From **measurement view**, press  button to enter **parameter view**. The first level menu (QUICK START) will display. Press  button to enter this menu.
2. Press  button again to enter "Quick commissioning wizard" (COMMISSION).

In the wizard, it is not necessary to press  button to navigate to the next step. In each step, you are taken directly to **edit view**.

3. Set "Operation", then "Material type".

Subsequent wizard parameters will vary depending on the application you choose. See links below to step you through the wizard appropriate to your application.

4. Select "Yes" to confirm all parameter changes as the final step in the quick commissioning wizard, and return to **parameter view**. "DONE" will appear on the main line of the display.
5. Press  button three times to return to **measurement view**.

For more information about commissioning a Level, Space, Distance or Custom application, go to Quick commissioning: Level/Space/Distance/Custom (Page 49).

For more information about commissioning a Volume application, go to Quick commissioning: Volume (Page 54).

For more information about commissioning a Volume flow application, go to Quick commissioning: Volume flow (Page 60).

Note

Important information regarding the use of commissioning wizard

- A reset to factory defaults should be performed before running "Quick commissioning wizard" if the device has been used in a previous application. See Reset (03-04.02) (Page 142).
 - Settings for quick commissioning wizard are inter-related and changes apply only after "Confirm" is set to 'Yes' in final step.
 - Do not use quick commissioning wizard to modify individual parameters. (See instead chapter Parameter assignment - Local (Page 109).) Perform customization for your application only *after* "Quick commissioning wizard" has been completed.
-

Note

Wizard operation requires 22.5 mA

Device output will read 22.5 mA during wizard operation. When wizard completes, device output will return to normal behavior.

Note

Commissioning wizard may fail due to invalid configuration

Device may show "ERROR" if the commissioning wizard completes with some invalid configurations. Invalid value(s) may be stored in the parameter(s).

- Review application parameters, then perform a "Factory reset" or re-run the "Quick commissioning wizard" with proper values to clear the invalid configuration.
-

Note

Update of process value on display when commissioning wizard run via EDD

Process values shown in **measurement view** on local display will not automatically update to reflect a change made remotely via "Wizard - Quick start...".

- To have device process values update when configured remotely, use local buttons to take device in and out of **measurement view** (i.e. go to **parameter view** then back to **measurement view**).
-

Quick commissioning: Level/Space/Distance/Custom

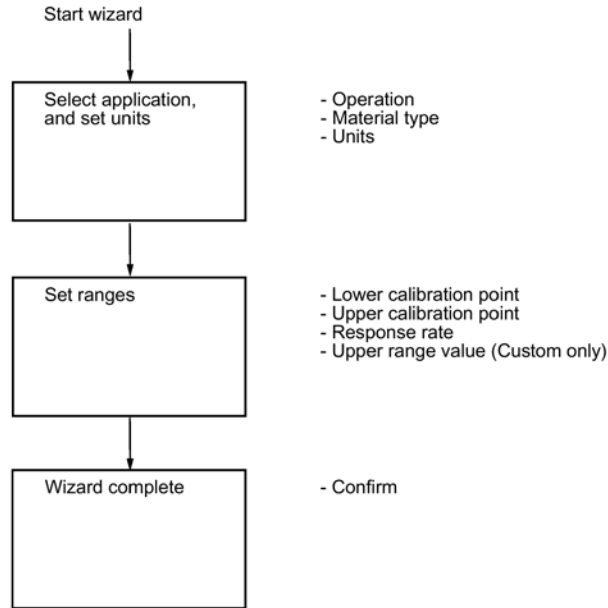

Note

Distance and Custom applications

- When "Operation" is set to "Distance", setting the upper calibration point is not required (will not appear in the wizard).
- Only when "Operation" is set to "Custom", is the upper range value required (will appear in the wizard).

Note

Output remains active

While the device is being configured, the output remains active and continues to respond to changes in the device.

Note

Parameter options

In the following wizard steps, a full list of options for each parameter is shown. However, some options may not appear on the device, based on the application selected.

Operation

Sets operation mode which defines output and local display.

Setting	Level	LEVEL
	Space	SPACE
	Distance	DIST
	Volume	VOL
	Volume flow	VFLOW
	Custom	CUSTM
Default	Level	LEVEL

Note

Completing a Custom setup

For a custom application ("Operation" set to "Custom"), at least one pair of input and output breakpoints (parameters "X-value" and "Y-value") must be defined, *after* the wizard is complete. See Customized characteristic curve (M 02-07.02) (Page 130).

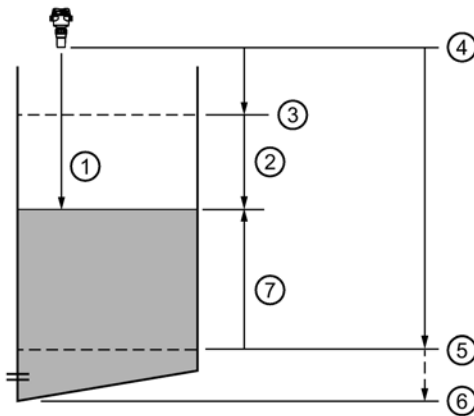

- ① Distance
- ② Space
- ③ Upper calibration point
- ④ Sensor reference point
- ⑤ Lower calibration point
- ⑥ Far range
- ⑦ Level

Setting		Description	Reference point
Level	LEVEL	Height of material	Lower calibration point (process empty level)
Space	SPACE	Distance to material surface	Upper calibration point (process full level)
Distance	DIST		Sensor reference point
Custom	CUSTM	Linearization table (level/volume or level/flow breakpoints)	Lower calibration point

Material type

Used to optimize performance based on material type.

Setting	Liquid	LQD
	Solid	SOLID
Default	Liquid	LQD

Units

Sets measurement units used.

			Default
Setting	Meters	m	3 decimal places
	Centimeters	cm	1 decimal place
	Millimeters	mm	0 decimal places
	Feet	Ft	3 decimal places
	Inches	in	2 decimal places
Default	Meters	m	3 decimal places

Note

Dynamic decimal places

Each setting for parameter "Units" has a default number of decimal places used to show the process value on the local display. However, if the value is too large to show on the segment display, the decimal places will be automatically adjusted to show the process value.

Note

Process value too large to display

In some cases, even with dynamic decimal places, it is possible that the process value be too large to show on the local display, "#####" will show instead.

If this occurs in a typical application:

- Adjust parameter "Units" so that a smaller value can be shown, e.g. use meters instead of millimeters.

If this occurs in a custom application:

- Adjust parameter "Custom units" so that a smaller value can be shown, e.g. use tons instead of pounds.
- Note that a change to custom units also requires a scaling adjustment (see Upper range value (Page 53)).

Custom units can only be defined via remote operation (see Custom units (Page 150)).

Lower calibration point

Sets distance from sensor reference point to lower calibration point: usually process empty level.

Setting	<ul style="list-style-type: none"> 0 to 6 m (6 m device) 0 to 12 m (12 m device)
Default	<ul style="list-style-type: none"> 6 m (6 m device) 12 m (12 m device)

Defined in parameter "Units".

Upper calibration point

Sets distance from sensor reference point to upper calibration point: usually process full level.

Setting	<ul style="list-style-type: none"> 0 to 6 m (6 m device) 0 to 12 m (12 m device)
Default	0 m

Defined in parameter "Units".

Response rate

Sets reaction speed of device to measurement changes in target range.

Use a setting just faster than the maximum filling or emptying rate (whichever is faster).

Note

Response rate

The parameter "Response rate" can only be set through the "Quick commissioning" wizard and any changes made to parameters "Fill rate", "Empty rate" or "Damping value" following the completion of the wizard will supersede the response rate setting.

Setting	Slow	SLOW	0.1 m/min (fill/empty rate)
	Medium	MED	1.0 m/min (fill/empty rate)
	Fast	FAST	10.0 m/min (fill/empty rate)
Default	Slow		

Further information can be found in Measurement response (Page 193).

Upper range value

Sets process value that corresponds to 20 mA loop current.

Setting	0 to 9999999
Default	100 <Custom units>

Note

"Upper range value" (URV) versus "Upper scaling point"

- When parameter "Upper range value" is set within the "Quick commissioning wizard", the parameter "Upper scaling point" is automatically adjusted to the same value.
 - Setting a value for either parameter *outside* of the wizard will not automatically adjust the other value.
-

Note

Changing custom units

If a change is made to custom units, be sure to rescale the output, as rescaling for custom units is not handled automatically by the device.

- Use parameters "Upper range value" and "Upper scaling point" to rescale output.
-

Confirm

Applies settings as last step in wizard.

Setting	Yes. Wizard completes and settings are applied.	YES
	No. Returned to start of wizard. (Settings are saved to perform wizard again, but not applied until "Confirm" set to "YES".)	NO
Default	No	NO

Quick commissioning: Volume

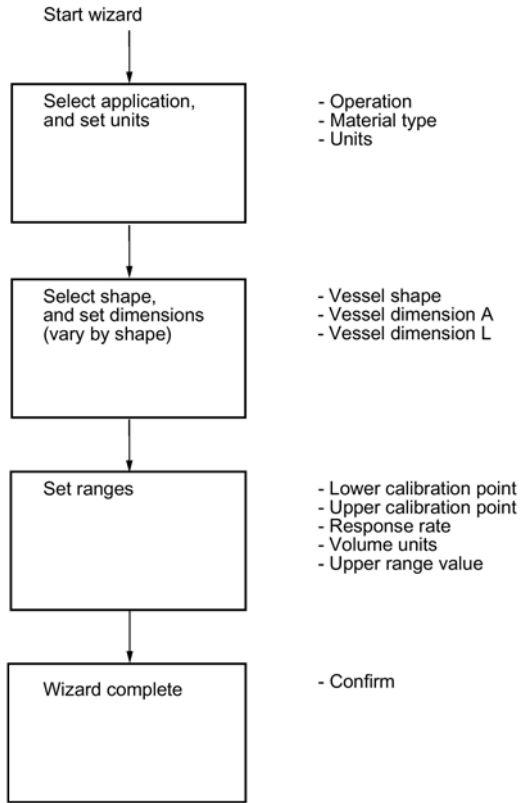

Note

Output remains active

While the device is being configured, the output remains active and continues to respond to changes in the device.

Note

Parameter options

In the following wizard steps, a full list of options for each parameter is shown. However, some options may not appear on the device, based on the application selected.

Operation

Sets operation mode which defines output and local display.

Setting	Level	LEVEL
	Space	SPACE
	Distance	DIST
	Volume	VOL
	Volume flow	VFLOW
	Custom	CUSTM
Default	Level	LEVEL

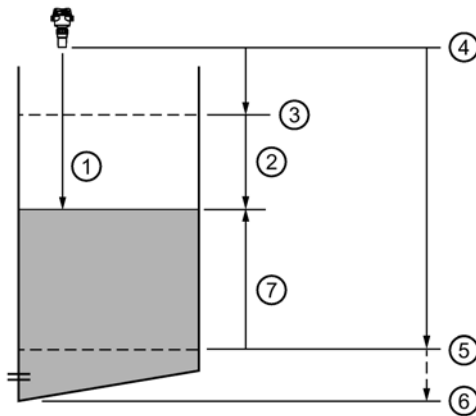

- | | |
|---------------------------|---------------------------|
| ① Distance | ⑤ Lower calibration point |
| ② Space | ⑥ Far range |
| ③ Upper calibration point | ⑦ Level |
| ④ Sensor reference point | |

Setting		Description	Reference point
Volume	VOL	Volume of material in Volume units (based on level)	Lower calibration point

Material type

Used to optimize performance based on material type.

Setting	Liquid	LQD
	Solid	SOLID
Default	Liquid	LQD

Units

Sets measurement units used.

			Default
Setting	Meters	m	3 decimal places
	Centimeters	cm	1 decimal place
	Millimeters	mm	0 decimal places
	Feet	Ft	3 decimal places
	Inches	in	2 decimal places
Default	Meters	m	3 decimal places

Note

Dynamic decimal places

Each setting for parameter "Units" has a default number of decimal places used to show the process value on the local display. However, if the value is too large to show on the segment display, the decimal places will be automatically adjusted to show the process value.

Note

Process value too large to display

In some cases, even with dynamic decimal places, it is possible that the process value be too large to show on the local display, "#####" will show instead.

If this occurs in a typical application:

- Adjust parameter "Units" so that a smaller value can be shown, e.g. use meters instead of millimeters.

If this occurs in a custom application:

- Adjust parameter "Custom units" so that a smaller value can be shown, e.g. use tons instead of pounds.
- Note that a change to custom units also requires a scaling adjustment (see Upper range value (Page 58)).

Custom units can only be defined via remote operation (see Custom units (Page 150)).

Vessel shape

Sets vessel shape, and allows device to calculate volume instead of level.

Settings	Linear vessel	LINR
	Conical bottom vessel	CONIC
	Parabolic bottom vessel	PARAB
	Half sphere bottom vessel	HALF
	Flat sloped bottom vessel	FLAT
	Cylinder vessel	CYLIN
	Parabolic ends vessel	PARAE
	Sphere vessel	SPHER
Default	Linear vessel	LINR

Vessel dimension A

Sets height of vessel bottom when bottom is conical, parabolic, half spherical, or flat sloped. If horizontal parabolic ends vessel, sets depth of end.

Setting	0 to 99.999 m
Default	0

See Vessel shape (02-05.01) (Page 121) for illustration.

Vessel dimension L

Sets length of cylindrical section of horizontal parabolic ends vessel.

Setting	0 to 99.999 m
Default	0

See Vessel shape (02-05.01) (Page 121) for illustration.

Lower calibration point

Sets distance from sensor reference point to lower calibration point: usually process empty level.

Setting	<ul style="list-style-type: none"> • 0 to 6 m (6 m device) • 0 to 12 m (12 m device)
Default	<ul style="list-style-type: none"> • 6 m (6 m device) • 12 m (12 m device)

Defined in parameter "Units".

Upper calibration point

Sets distance from sensor reference point to upper calibration point: usually process full level.

Setting	<ul style="list-style-type: none"> • 0 to 6 m (6 m device) • 0 to 12 m (12 m device)
Default	0 m

Defined in parameter "Units".

Response rate

Sets reaction speed of device to measurement changes in target range.

Use a setting just faster than the maximum filling or emptying rate (whichever is faster).

Note

Response rate

The parameter "Response rate" can only be set through the "Quick commissioning" wizard and any changes made to parameters "Fill rate", "Empty rate" or "Damping value" following the completion of the wizard will supersede the response rate setting.

Setting	Slow	SLOW	0.1 m/min (fill/empty rate)
	Medium	MED	1.0 m/min (fill/empty rate)
	Fast	FAST	10.0 m/min (fill/empty rate)
Default	Slow		

Further information can be found in Measurement response (Page 193).

Volume units

Sets volume measurement units.

Setting	Cubic meters	m3
	Liters	l
	US gallons	Ga
	Imperial gallons	IGa
Default	Cubic meters	

Upper range value

Sets process value that corresponds to 20 mA loop current.

Setting	0 to 9999999
Default	100 liters

Note

"Upper range value" (URV) versus "Upper scaling point"

- When parameter "Upper range value" is set within the "Quick commissioning wizard", it automatically sets the "Upper scaling point" to the same value.
 - Setting a value for either parameter *outside* of the wizard, will not automatically adjust the other value.
-

Note

Changing custom units

If a change is made to custom units, be sure to rescale the output, as rescaling for custom units is not handled automatically by the device.

- Use parameters "Upper range value" and "Upper scaling point" to rescale output.
-

Confirm

Applies settings as last step in wizard.

Setting	Yes. Wizard completes and settings are applied.	YES
	No. Returned to start of wizard. (Settings are saved to perform wizard again, but not applied until "Confirm" set to "YES".)	NO
Default	No	NO

Quick commissioning: Volume flow

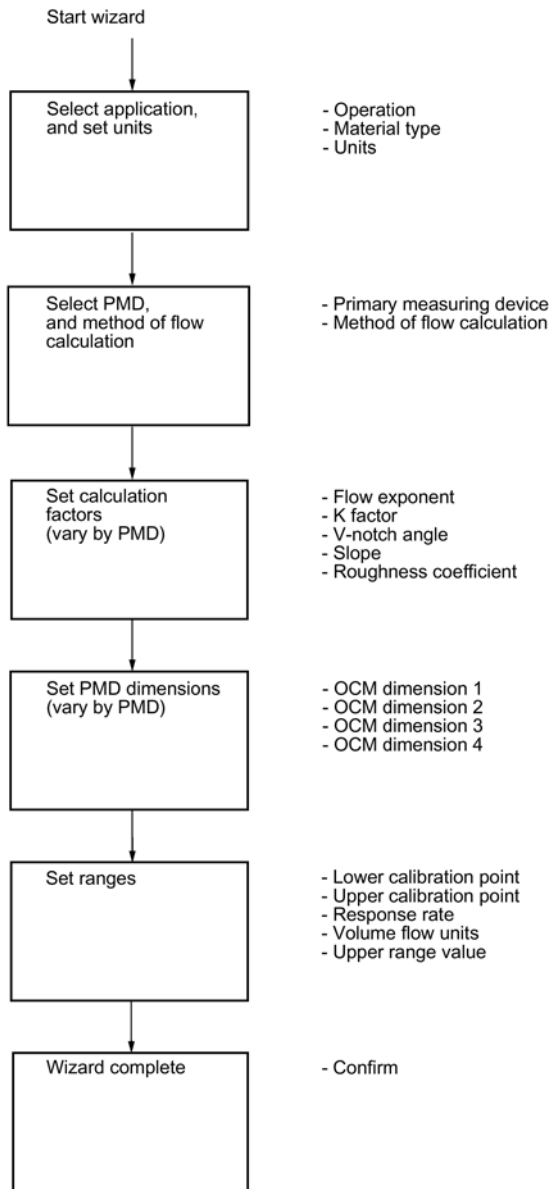

Note

Output remains active

While the device is being configured, the output remains active and continues to respond to changes in the device.

Note

Parameter options

In the following wizard steps, a full list of options for each parameter is shown. However, some options may not appear on the device, based on the application selected.

Operation

Sets operation mode which defines output and local display.

Setting	Level	LEVEL
	Space	SPACE
	Distance	DIST
	Volume	VOL
	Volume flow	VFLOW
	Custom	CUSTM
Default	Level	LEVEL

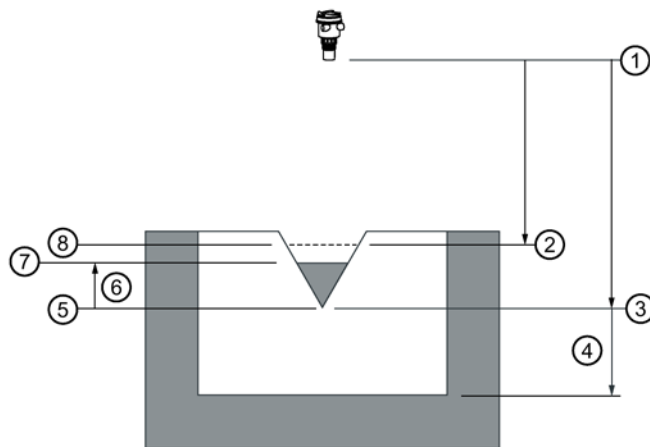

- | | |
|---------------------------|---|
| ① Sensor reference point | ⑤ Zero level (head) |
| ② Upper calibration point | ⑥ Level (head) |
| ③ Lower calibration point | ⑦ Material surface |
| ④ Far range | ⑧ Upper scaling point (maximum volume/flow) |

Setting	Description	Reference point
Volume flow	VFLOW	Flow rate in an open channel in Volume flow units
		Zero level, zero flow

Material type

Used to optimize performance based on material type.

Setting	Liquid	LQD
	Solid	SOLID
Default	Liquid	LQD

Units

Sets measurement units used.

			Default
Setting	Meters	m	3 decimal places
	Centimeters	cm	1 decimal place
	Millimeters	mm	0 decimal places
	Feet	Ft	3 decimal places
	Inches	in	2 decimal places
Default	Meters	m	3 decimal places

Note

Dynamic decimal places

Each setting for parameter "Units" has a default number of decimal places used to show the process value on the local display. However, if the value is too large to show on the segment display, the decimal places will be automatically adjusted to show the process value.

Note

Process value too large to display

In some cases, even with dynamic decimal places, it is possible that the process value be too large to show on the local display, "#####" will show instead.

If this occurs in a typical application:

- Adjust parameter "Units" so that a smaller value can be shown, e.g. use meters instead of millimeters.

If this occurs in a custom application:

- Adjust parameter "Custom units" so that a smaller value can be shown, e.g. use tons instead of pounds.
- Note that a change to custom units also requires a scaling adjustment (see Upper range value (Page 68)).

Custom units can only be defined via remote operation (see Custom units (Page 150)).

Primary measuring device

Sets the type of primary measuring device (PMD) used.

Setting	Exponential devices	EXPON
	Rectangular flume BS-3680	RECFL
	Round nose horizontal crest weir BS-3680	RNHWR
	Trapezoidal flume BS-3680	TRPFL
	U-flume BS-3680	UFLM
	Finite crest weir BS-3680	FINWR
	Thin plate rectangular weir BS-3680	TPRWR
	Thin plate V-notch weir BS-3680	TPVWR
	Rectangular weir contracted	RWRC
	Round pipe	RPIPE
	Palmer-Bowlus flume	PBFLM
	H-flume	HFLM
Default	Exponential devices	EXPON

Method of flow calculation

Sets method of flow calculation.

Setting	Absolute	ABS
	Ratiometric	RATIO
Default	Absolute	ABS

Set this parameter to "Ratiometric" only if the primary measuring device (PMD) supports ratiometric calculations. (Note that Palmer Bowlus Flume and H-Flume support ratiometric calculations only.) For more details on absolute and ratiometric calculations, see Method of flow calculation (Page 199).

Flow exponent

Sets exponent for flow calculation formula.

Setting	-999 to 9999
Default	1.55

Use if parameter "Primary measuring device" is set to "Exponential devices". The flow exponent is used to create an exponential curve with end points set by "Upper scaling point" and Zero level (head), and with the curve based on the specified exponent.

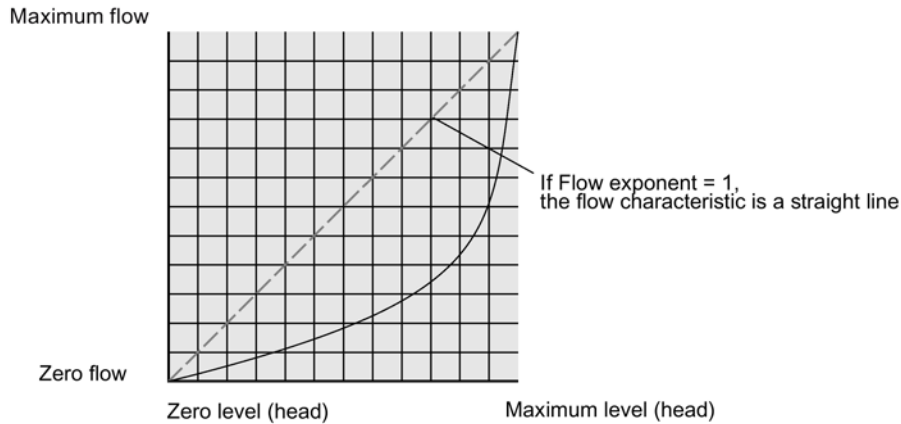

The exponential equation is

$$Q = KH^{\text{Flow exponent}}$$

Where:

Q = flow

K = constant factor

H = level (head)

Use the exponent specified by the PMD manufacturer, if available, or relevant Open Channel Monitoring reference material.

K-factor

Sets constant used in volume flow calculation formula, for absolute calculation of exponential device only.

Setting	-999 to 99999
Default	1.0

Use if parameter "Primary measuring device" is set to "Exponential devices". The constant factor (K-factor) is used to create an exponential curve with end points set by "Upper scaling point" and Zero level (head), and with the curve based on the specified exponent.

Note

Accurate flow calculation

In a volume flow application using **exponential device**, and **absolute** method of flow calculation, the following must be consistent for flow calculation to be valid:

- Engineering units for level (parameter "Units")
- Engineering units for volume flow (parameter "Volume flow units")
- Constant factor (parameter "K-factor").

V-notch angle

Sets V-notch angle used in volume flow calculation formula.

Setting	25° to 95°
Default	25°

Use when parameter "PMD dimensions" is set to "Thin plate V-Notch weir BS-3680".

Slope

Sets flow slope used in volume flow calculation formula.

Setting	0 to 1
Default	0

Use when parameter "PMD dimensions" is set to "Trapezoidal flume BS-3680" or "Round pipe".

Roughness coefficient

Sets flow roughness coefficient used in volume flow calculation formula.

Setting	-999 to 9999
Default	0

Use when parameter "PMD dimensions" is set to "Round pipe".

PMD dimensions

Sets dimensions of primary measuring device (PMD), to calculate volume.

The following table is a reference to the parameters that must be set for each PMD.

Supported PMD	Dimensions required
Exponential devices	
	Flow exponent
	K-factor
Rectangular flume BS-3680	
	OCM dimension 1: Approach width
	OCM dimension 2: Throat width
	OCM dimension 3: Hump height
	OCM dimension 4: Throat length
Round nose horizontal crest weir BS-3680	
	OCM dimension 1: Crest width
	OCM dimension 2: Crest height
	OCM dimension 3: Crest length

Supported PMD	Dimensions required
Trapezoidal flume BS-3680	
	OCM dimension 1: Approach width
	OCM dimension 2: Throat width
	OCM dimension 3: Hump height
	OCM dimension 4: Throat length
	Slope
U-flume BS-3680	
	OCM dimension 1: Approach diameter
	OCM dimension 2: Throat diameter
	OCM dimension 3: Hump height
	OCM dimension 4: Throat length
Finite crest weir BS-3680	
	OCM dimension 1: Crest width
	OCM dimension 2: Crest height
	OCM dimension 3: Crest length
Thin plate rectangular weir BS-3680	
	OCM dimension 1: Approach width
	OCM dimension 2: Crest width
	OCM dimension 3: Crest height
Thin plate V-notch weir BS-3680	
	V-Notch angle
Rectangular weir contracted	
	OCM dimension 1: Crest width
Round pipe	
	OCM dimension 1: Pipe diameter
	Slope
	Roughness coefficient
Palmer-Bowlus flume	
	OCM dimension 1: Maximum flume width
H-flume	
	OCM dimension 1: Flume height
Custom	
	Volume (up to 32)
	Flow (up to 32)

OCM dimension 1-4

Sets OCM dimension for each directly supported primary measuring device (PMD).

See table under parameter "PMD dimensions" to relate "OCM Dimension 1 - 4" to a specific dimension for each directly supported primary measuring device. For PMDs that are not directly supported, use a universal flow calculation. See Custom calculation support (Page 99).

For more information, see Open Channel Monitoring (OCM) (Page 80).

Lower calibration point

Sets distance from sensor reference point to lower calibration point: usually process empty level.

Setting	<ul style="list-style-type: none"> • 0 to 6 m (6 m device) • 0 to 12 m (12 m device)
Default	<ul style="list-style-type: none"> • 6 m (6 m device) • 12 m (12 m device)

Defined in parameter "Units".

Upper calibration point

Sets distance from sensor reference point to upper calibration point: usually process full level.

Setting	<ul style="list-style-type: none"> • 0 to 6 m (6 m device) • 0 to 12 m (12 m device)
Default	0 m

Defined in parameter "Units".

Response rate

Sets reaction speed of device to measurement changes in target range.

Use a setting just faster than the maximum filling or emptying rate (whichever is faster).

Note

Response rate

The parameter "Response rate" can only be set through the "Quick commissioning" wizard and any changes made to parameters "Fill rate", "Empty rate" or "Damping value" following the completion of the wizard will supersede the response rate setting.

Setting	Slow	SLOW	0.1 m/min (fill/empty rate)
	Medium	MED	1.0 m/min (fill/empty rate)
	Fast	FAST	10.0 m/min (fill/empty rate)
Default	Slow		

Further information can be found in Measurement response (Page 193).

Volume flow units

Sets measurement units used when parameter "PV selection" set to "Volume flow".

Setting	Liters per second	l/S
	Liters per minute	l/m
	Cubic feet per second	Ft3/S
	Cubic feet per day	Ft3/d
	US gallons per minute	Ga/m
	US gallons per day	Ga/d
	Imperial gallons per minute	lGa/m
	Imperial gallons per day	lGa/d
	Cubic meters per hour	m3/h
	Cubic meters per day	m3/d
	US million gallons per day	MGI/d
Default	Liters per second	l/S

Upper range value

Sets process value that corresponds to 20 mA loop current.

Setting	0 to 9999999
Default	100 liters per second

Note

"Upper range value" (URV) versus "Upper scaling point"

- When parameter "Upper range value" is set within the "Quick commissioning wizard", it automatically sets the "Upper scaling point" to the same value.
- Setting a value for either parameter *outside* of the wizard, will not automatically adjust the other value.

Note

Changing custom units

If a change is made to custom units, be sure to rescale the output, as rescaling for custom units is not handled automatically by the device.

- Use parameters "Upper range value" and "Upper scaling point" to rescale output.

Confirm

Applies settings as last step in wizard.

Setting	Yes. Wizard completes and settings are applied.	YES
	No. Returned to start of wizard. (Settings are saved to perform wizard again, but not applied until "Confirm" set to "YES".)	NO
Default	No	NO

7.2.4.2 AFES wizard

Used to prevent false echo detection over a specified range.

Use AFES wizard if there are known obstructions in the application and if false echoes are anticipated. Perform the AFES wizard when the material level is low.

Note

Wizard operation requires 22.5 mA

Device output will read 22.5 mA during wizard operation. When wizard completes, device output will return to normal behavior.

To run the wizard, enter the auto false echo suppression range.

Auto false echo suppression range

Sets end point of the learned TVT distance.

Setting	<ul style="list-style-type: none"> • 0 to 6 m (6 m device) • 0 to 12 m (12 m device)
Default	1 m

To calculate value

1. Determine the auto false echo suppression range by measuring the actual distance from the sensor reference point to the material surface using a rope or tape measure.
2. Subtract 0.5 m (20") from this distance and use the resulting value.

Note

For best results with AFES

- Set up auto false echo suppression during commissioning if possible, by running "Auto false echo suppression wizard".
- Ensure material level is below all known obstructions at the moment when "Auto false echo suppression wizard" learns the TVT. Ideally the vessel should be empty or almost empty.
- Use auto false echo suppression only if target is greater than one meter from transducer face (sensor reference point)
- Note the distance to material level when learning the echo profile, and set value in parameter "Auto false echo suppression range" to a shorter distance to avoid the material echo being screened out.
- If the vessel contains an agitator, it should be running.

Once the wizard completes successfully, parameter "Auto false echo suppression" is set to "Enabled" and the learned TVT will be used.

For more information about auto false echo suppression, see Auto false echo suppression and Custom TVT (Page 190).

Confirm

Applies settings as last step in wizard.

Setting	Yes. Wizard completes and settings are applied.	YES
	No. Returned to start of wizard. (Settings are saved to perform wizard again, but not applied until "Confirm" set to "YES".)	NO
Default	No	NO

7.2.5 Requesting an echo profile

After commissioning the device, an echo profile may be viewed using a remote engineering system, such as SIMATIC PDM.

For details, see Echo profile utilities (Page 231).

7.2.6 Device address

Setting a device address is not necessary for local operation, but must be set if configuring the device for use on a HART network. See Polling address (04.01) (Page 144).

7.2.7 Testing the configuration

After configuring the device, it is recommended that you test the device to ensure that it performs to your specifications. This test can be run in simulation mode or by varying the actual process value in the application. The latter is preferred, as it more accurately represents operating conditions. However, if it is not possible to do a physical test, a simulation will ensure that control programming is correct. For more details, see Simulation (Page 103).

7.3 Application examples

7.3.1 Level application example

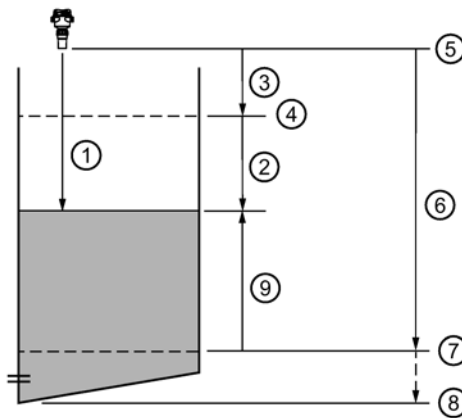

- | | |
|---------------------------|---------------------------|
| ① Distance (5.5 m) | ⑥ 9.0 m |
| ② Space (4.5 m) | ⑦ Lower calibration point |
| ③ 1.0 m | ⑧ Far range |
| ④ Upper calibration point | ⑨ Level (3.5 m) |
| ⑤ Sensor reference point | |

Quick commissioning parameter	Setting/value	Description
Operation	Level	Material level referenced from "Lower calibration point"
Material type	Liquid	
Units	m	Sensor measurement units
Lower calibration point	9.0 m	Process empty level
Upper calibration point	1.0 m	Process full level
Response rate	Slow	Sets "Fill rate" and "Empty rate" to 0.1 m/min

The application is a vessel that takes an average 3 hours (180 minutes) to fill and 3 weeks to empty.

$$\begin{aligned}
 \text{"Fill rate"} &= (\text{"Lower calibration point"} - \text{"Upper calibration point"}) / \text{fastest of fill or empty time} \\
 &= (9 \text{ m} - 1 \text{ m}) / 180 \text{ min} \\
 &= 8 \text{ m} / 180 \text{ min.} = 0.04 \text{ m/min}
 \end{aligned}$$

7.3.2 Volume flow application example

In this example, a 12 inch (0.305 m) Parshall Flume has been installed in an open channel. As per the supplier's data sheet, the device has been rated for a maximum flow of 1143 m³ per hour at a maximum level of 0.6 m. The Parshall Flume is considered an exponential device, therefore the supplier's data sheet includes a flow exponent value of 1.522. The SITRANS Probe LU240 has been installed 1.6 m above the channel.

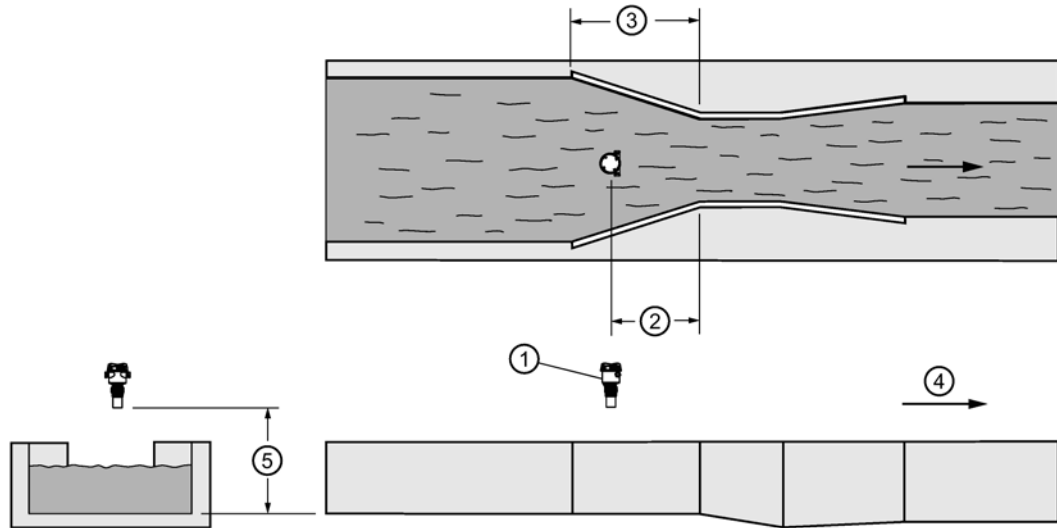

- ① SITRANS Probe LU240
- ② 2/3 of converging dimension
- ③ Converging dimension
- ④ Direction of flow
- ⑤ Zero level (head)

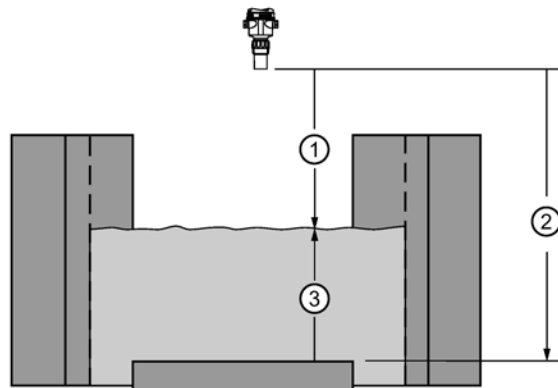

- ① Upper calibration point (1.0 m)
- ② Lower calibration point (1.6 m)
- ③ Upper scaling point (0.6 m)

Quick commissioning parameter	Setting/value		Description
Operation	Volume flow	VFLOW	
Material type	Liquid	LQD	
Units	Meters	m	Units corresponding to the level (head) measurement.
Primary measuring device (PMD)	Exponential	EXPON	Parshall Flumes are a type of exponential device.
Method of flow calculation	Ratiometric	RATIO	Used when the maximum level and maximum flow values ("Upper scaling point", "Upper range value") are provided.
Flow exponent		1.522	Available from the PMD supplier data sheet.
Lower calibration point		1.6	The distance to the empty point or bottom of the flume. This sets the material level at 4 mA.
Upper calibration point		1.0	The distance to the maximum level. This sets the "Upper range value".
Response rate	Medium (1.0 m/min)	MED	Response rate is set to be faster than the fastest rise in material level under typical operating conditions.
Upper scaling point		0.6 m	Available from the PMD supplier data sheet. ("Upper scaling point" is set by "Upper range value" in "Quick commissioning wizard".)
Volume flow units	Cubic meters per hour	m3/h	Set per end user requirements.
Upper range value		1143	Available from the PMD supplier data sheet.

Operating

8.1 Operating instructions

This chapter provides details on the general operation and functionality of the SITRANS Probe LU240. For instructions on the use of the device local display HMI, refer to Local display (Page 40).

For a complete list of parameters, see Parameter assignment - Local (Page 109) or Parameter assignment - Remote (Page 147).

8.1.1 Starting measurement

The SITRANS Probe LU240 is a single point device. After startup, the **measurement view** reports a list of measurement values in the order shown below.

Process value	Text as shown in measurement view of device
Level	LEVEL
Space	SPACE
Distance	DISTANCE
Volume*	VOLUME
Volume flow*	VOLUME FLOW
Custom*	CUSTOM
Loop current**	LOOP CURRENT
Primary variable**	PV
% of range**	% OF RANGE
Sensor temperature	SENSOR TEMP

* "Volume", "Volume flow", and "Custom" are not visible until configured.

** Measurements based on primary variable (PV) selection. Default PV is set to "Distance" at startup. (See "Operation" in quick commissioning wizard, or parameter "PV selection" in menu "Setup > Select output" to change this default.)

Note

Damped PV

The process value that is set as the primary variable (PV) for the application is damped using values in parameters "Damping value" and "Sensor damping value".

All other process values (not set by default or selected as the main PV), are damped only by the value in parameter "Sensor damping value".

The device starts with "Distance" as the default measurement, and a preset of 6 meters (for a 6 m device, 12 m for a 12 m device) for lower calibration point. Change the following common parameters in the quick commissioning wizard to reflect your application.

Parameter	Sample value
Operation	Level
Response rate	Medium
Units	meters
Lower calibration point	6
Upper calibration point	2

8.1.2 Measurement conditions

The following information will help you configure your device for optimal performance and reliability.

Response Rate

The response rate of the device influences the measurement reliability. Use the slowest rate possible with the application requirements.

Note

Response rate

The parameter "Response rate" is only available via the quick commissioning wizard. If changes are made outside of the wizard, to parameters "Fill rate" and "Empty rate", or "Damping value", these changes will override the response rate setting in the wizard. See Response rate (Page 52).

Dimensions

Dimensions of the vessel, wet well, or reservoir (other than lower and upper calibration points) are only important if you require volume readings. In this case, all dimensions are used to calculate the volume value in terms of level.

Fail-safe

The fail-safe parameters ensure that the device defaults to an appropriate state when a valid level reading is not available. (See Fault codes and corrective actions (Page 165) for a list of fault codes related to fail-safe.)

- Parameter "Fault current" defines the behavior (mA output value to report) when an error condition, such as loss of echo, is detected.
- A fail-safe timer also activates when an error condition is detected. "Fail-safe LOE timer" sets the amount of time the loss of echo will persist before device enters fail-safe mode.
- Upon expiration of the timer, and if device is still in an error condition, the mA output value reported is based on value set in parameter "Fail-safe loss of echo".

If fail-safe operation activates frequently, see Diagnosing and troubleshooting (Page 161).

8.1.3 mA control

mA output

The device has one mA output, used for communications with other devices.

Example:

Configuring the mA output to send a 4 to 20 mA signal corresponding to a scaled value of 10% to 90% of maximum process level:

Parameter	Sample value	Description
PV selection	Level	Set mA proportional to level reading
Lower range value	1.2	Set 4 mA at process level equal to 10% of maximum ("Lower calibration point" minus "Upper calibration point")*
Upper range value	10.8	Set 20 mA at process level equal to 90% of maximum ("Lower calibration point" minus "Upper calibration point")**
Lower saturation limit	3.55	Set lower limit for saturation range, past which the loop current cannot decrease.
Upper saturation limit	22.8	Set upper limit for saturation range, past which the loop current cannot increase.

* If the level reading drops below 1.2 m, the mA output drops below 4 mA.

** If the level reading rises above 10.8 m, the mA output rises above 20 mA.

Note

Default mA values

If default values (4 and 20 mA) are used for the upper and lower saturation limits, the mA output (shown under "Loop current" in **measurement view** of device) will remain at the set mA limit, even if the level reading falls below/rises above the lower and upper range values.

Verifying the mA range

Check that the external device can track the entire 4 to 20 mA range sent by the device. Follow the steps below if actual mA readings differ between the device (shown under "Loop current" in **measurement view** of device) and an external device (such as a PLC).

1. To test the loop current, run the "Loop test wizard". Select a constant mA value to use in the test from a list of mA values, or set a custom mA value by selecting option "User", then set a value.
2. Check that the external device displays the same mA reading as the mA value set above.
3. If external device reading differs from the value manually set on the device, adjust the reading on the external device to match the reading on the device.

8.1.4 Volume

8.1.4.1 Vessel shape and dimensions

The device can be configured to suit many common vessel shapes. See Vessel shape (02-05.01) (Page 121). Whenever possible, use one of the pre-defined selections. If one of the pre-defined selections is not applicable, a custom volume calculation can be used. (Configure a custom application by setting parameter "Operation" or "PV selection" to option "Custom", then define your vessel shape using Custom (M 02-07) (Page 129).) For more details, see Volume calculation (Page 196).

Each vessel shape uses the empty distance value in its calculations of volume. See PV selection (02-01.01) (Page 110) for an illustration.

Some vessel shapes also require extra dimensions to calculate the volume. Do not estimate these values as they must be exact to ensure the accuracy of your volume calculations.

Example:

To configure volume for a vessel with a half-sphere bottom, set the following:

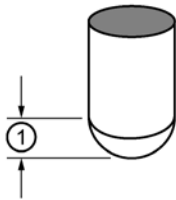

① Vessel dimension A

Parameter	Sample value	Description
Vessel shape	Half sphere bottom vessel	Sets correct vessel shape
Upper scaling point	100	Sets upper scaling at 100 (defined in "Volume units")
Vessel dimension A	1.3	Sets dimension A to 1.3 m

Note

Example outcome

- The default reading changes to a range from 0 to 100, which is the value in parameter Upper scaling point (02-05.05) (Page 124).
- The process empty value is still measured to the bottom of the vessel (value in parameter "Lower calibration point"), not the top of dimension A.

8.1.5 Volume flow

8.1.5.1 Flow calculation

The SITRANS Probe LU240 provides numerous open channel flow calculation features. The device can be configured to select the flow calculation specific to the primary measuring device (PMD), such as a flume or weir. If the PMD does not match any of the preset PMD calculations, a custom volume flow calculation can be used. (Configure a custom application by setting parameter "Operation" or "PV selection" to option "Custom", then define your PMD using Custom (M 02-07) (Page 129).) For more details, see Volume flow calculation (Page 198).

The device converts the level measurement into a volume flow rate.

8.1.5.2 Open Channel Monitoring (OCM)

An OCM installation is defined one of three ways, based on the Primary Measuring Device (PMD):

1. Dimensional

For some common weir and flume types. PDM dimensions are entered directly.

Rectangular flume BS-3680 (Page 88)

Round nose horizontal crest weir BS-3680 (Page 89)

Trapezoidal flume BS-3680 (Page 90)

U-flume BS-3680 (Page 91)

Finite crest weir BS-3680 (Page 92)

Thin plate rectangular weir BS-3680 (Page 93)

Thin plate V-notch weir BS-3680 (Page 94)

Rectangular weir contracted (Page 95)

Round pipe flume (Page 96)

Palmer-Bowlus flume (Page 97)

H-flume (Page 98)

2. Exponential

For most other weir and flume types. PMD exponents provided by the manufacturer are entered. Volume flow is calculated using parameter "Flow exponent", and the maximum value parameters ("Upper scaling point" and "Upper range value").

Standard weirs (Page 82)

Parshall flume (Page 84)

Leopold-Lagco flume (Page 85)

Cut throat flume (Page 86)

3. Custom

For all other PMDs, a level versus volume flow curve can be plotted based on known breakpoints, usually supplied by the PMD manufacturer.

Typical flow characterization (Page 99)

Example flumes (Page 100)

Example weir profiles (Page 101)

Methods to calculate volume flow

When using the device in a volume flow application, a method of flow calculation must be selected. There are two possible methods for calculating volume flow with the device: absolute or ratiometric, and different information must be entered for the device to carry out the calculation. For more details and an example, refer to Method of flow calculation (Page 199).

Common parameters

These common parameters are required for all installations.

Parameter	Sample value
Operation (Page 50) (set in quick commissioning wizard), or PV selection (02-01.01) (Page 110) (set in navigation view)	Volume flow
Response rate (Page 52)	Medium
Units (02-02.01) (Page 112)	Meters
Lower calibration point (02-03.03) (Page 116)	1.8
Upper calibration point (02-03.04) (Page 116)	0.4
Far range (03-01-02.02) (Page 133)	0.8

Setting zero level

Many PMDs start flowing higher than the traditional empty distance of the application. Account for the volume flow as follows:

Use parameter "Far range" where the empty level is set to the bottom of the weir and above the bottom of the channel. It should be used if the surface monitored can fall past the lower calibration point in normal operation without reporting a loss of echo. Set the value for parameter "Far range" to the lower calibration point plus the amount by which the surface monitored exceeds the lower calibration point. The value for parameter "Far range" can be greater than the range of the transmitter

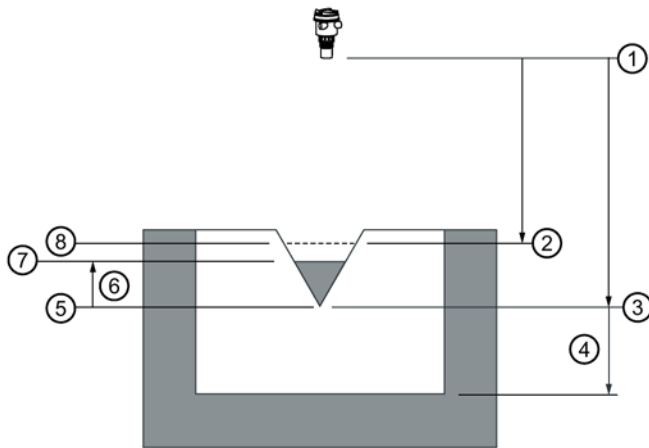

- | | |
|---------------------------|-----------------------|
| ① Sensor reference point | ⑤ Zero level |
| ② Upper calibration point | ⑥ Level |
| ③ Lower calibration point | ⑦ Material surface |
| ④ Far range | ⑧ Upper scaling point |

The examples on the following pages show this method.

PMDs with exponential level to volume flow function

For Primary Measuring Devices (PMDs) that measure flow by an exponential equation, use these parameters. Ensure that you use the correct exponent for your PMD; the values below are samples only.

Standard weirs

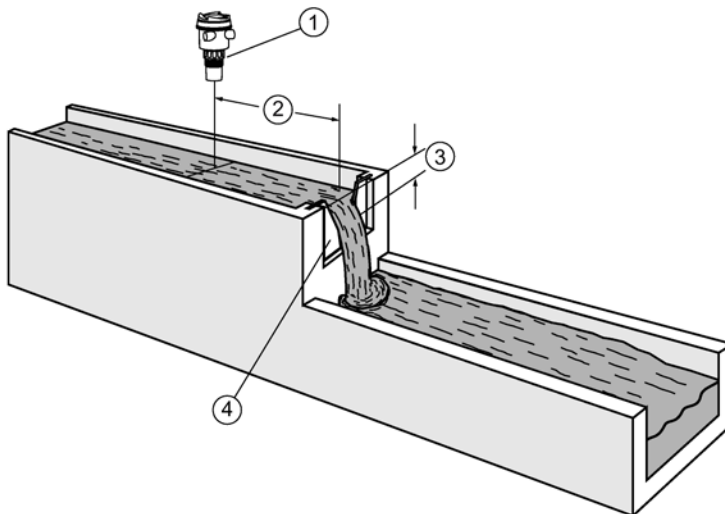

- | | |
|---------------------------------|----------------|
| ① SITRANS Probe LU240 | ③ Level |
| ② 3 to 4 x level _{max} | ④ Weir profile |

Applicable weir profiles

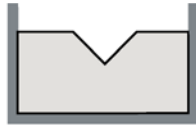

V-notch or
triangular



Suppressed
rectangular

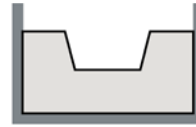

Cipolletti or
trapezoidal



Sutro or
proportional

Parameter	Value	
Primary measuring device (02-06.01) (Page 124)	Exponential devices	
Flow exponent (02-06-05.01) (Page 127)	Weir type	Value¹⁾
	V-notch	2.50
	Suppressed rectangular	1.50
	Cipolletti or trapezoidal	1.50
	Sutro or proportional	1.00
Upper scaling point (02-05.05) (Page 124)		
Upper range value (02-04.05) (Page 120)		
Volume flow units (02-06.03) (Page 125)		
Far range (03-01-02.02) (Page 133)		
K-factor (02-06-05.02) (Page 128) ²⁾		

¹⁾ Values are samples only. Consult weir manufacturer's documentation for correct flow exponent.

²⁾ Required for exponential device absolute calculation only.

Parshall flume

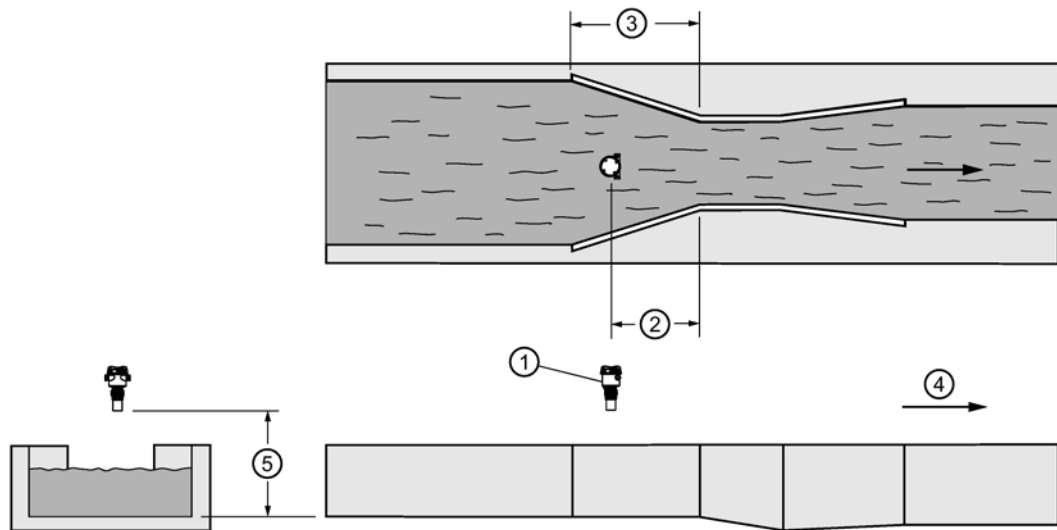

- ① SITRANS Probe LU240¹⁾
- ② 2/3 of converging dimension
- ③ Converging dimension
- ④ Direction of flow
- ⑤ Zero level

¹⁾ The device must be above the upper scaling point by at least the blanking value (Near range (03-01-02.01) (Page 133)).

Application information

- Sized by throat width
- Set on solid foundation
- For rated flows under free flow conditions, the level is measured at 2/3 the length of the converging section from the beginning of the throat section

Parameter	Value
Primary measuring device (02-06.01) (Page 124)	Exponential devices
Flow exponent (02-06-05.01) (Page 127)	1.522–1.607 ¹⁾
Upper scaling point (02-05.05) (Page 124)	
Upper range value (02-04.05) (Page 120)	
K-factor (02-06-05.02) (Page 128) ²⁾	

¹⁾ Typical Flow Exponent range for Parshall flume; consult your flume documentation.

²⁾ Required for exponential device absolute calculation only.

Leopold-Lagco flume

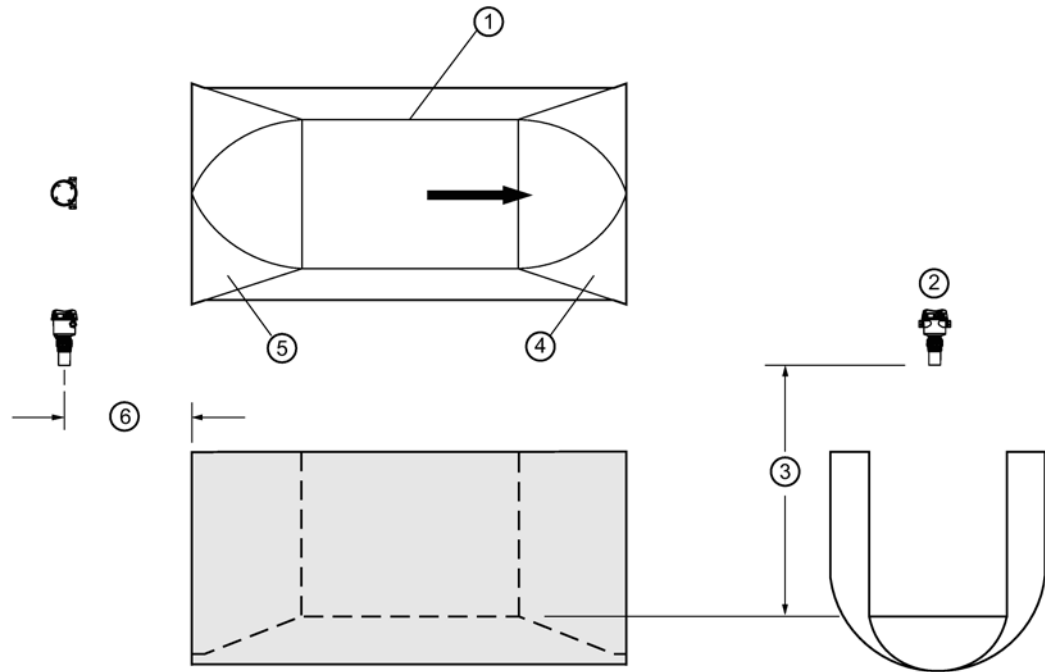

- ① Throat
② SITRANS Probe LU240¹⁾
③ Zero level
④ Diverging
⑤ Converging
⑥ Point of measurement

¹⁾ The device must be above the upper scaling point by at least the blanking value (Near range (03-01-02.01) (Page 133)).

Parameter	Value
Primary measuring device (02-06.01) (Page 124)	Exponential devices
Flow exponent (02-06-05.01) (Page 127)	1.547 ¹⁾
Upper scaling point (02-05.05) (Page 124)	
Upper range value (02-04.05) (Page 120)	
Volume flow units (02-06.03) (Page 125)	
K-factor (02-06-05.02) (Page 128) ²⁾	

¹⁾ Typical Flow Exponent range for Parshall flume; consult your flume documentation.

²⁾ Required for exponential device absolute calculation only.

Application information

- Designed to be installed directly into pipelines and manholes
- Leopold-Lagco may be classed as a rectangular Palmer-Bowlus flume
- Sized by pipe (sewer) diameter
- For rated flows under free flow conditions, the level is measured at a point upstream referenced to the beginning of the converging section. Refer to the following table:

Flume size pipe diameter in inches	Point of measurement	
	cm	inches
4-12	2.5	1
15	3.2	1.25
18	4.4	1.75
21	5.1	2
24	6.4	2.5
30	7.6	3
42	8.9	3.5
48	10.2	4
54	11.4	4.5
60	12.7	5
66	14.0	5.5
72	15.2	6

Cut throat flume

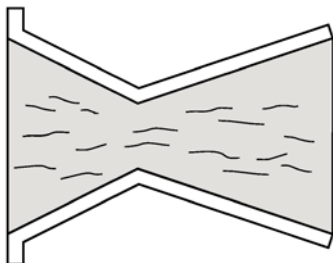

Application information

- Similar to Parshall flume except that the floor is flat bottomed and throat has no virtual length.
- Refer to manufacturer’s specifications for flow equation and point of level measurement.

Parameter	Value
Primary measuring device (02-06.01) (Page 124)	Exponential devices
Flow exponent (02-06-05.01) (Page 127)	1.56 - 2.00 ¹⁾
Upper scaling point (02-05.05) (Page 124)	
Upper range value (02-04.05) (Page 120)	
Volume flow units (02-06.03) (Page 125)	
K-factor (02-06-05.02) (Page 128) ²⁾	

1) Typical flow exponent range for Cut throat flume; consult your flume documentation.
 2) Required for exponential device absolute calculation only.

Khafagi-Venturi flume

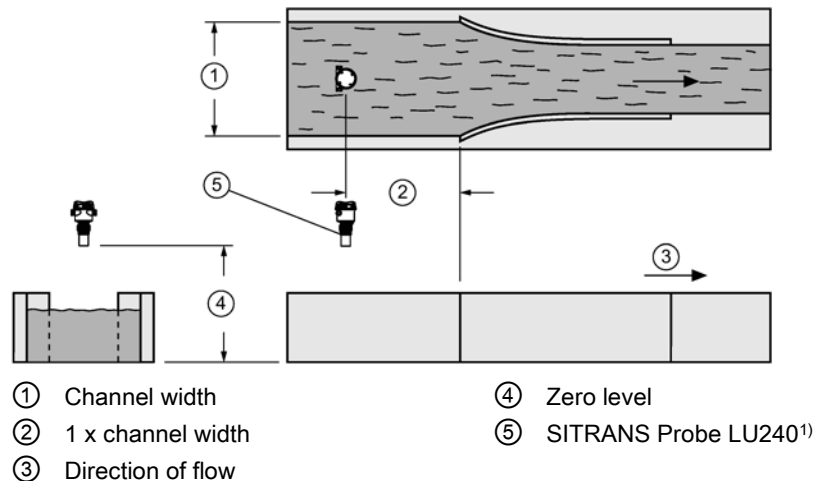

¹⁾ The device must be above the upper scaling point by at least the blanking value (Near range (03-01-02.01) (Page 133)).

Application information

- Similar to Parshall flume except that the floor is flat bottomed and the sidewalls are curved.
- For rated flows under free flow conditions, the level is measured 1 x (channel width) upstream from the beginning of the converging section.

Parameter	Value
Primary measuring device (02-06.01) (Page 124)	Exponential devices
Flow exponent (02-06-05.01) (Page 127)	1.55 (Consult your flume documentation.)
Upper scaling point (02-05.05) (Page 124)	
Upper range value (02-04.05) (Page 120)	
Volume flow units (02-06.03) (Page 125)	
K-factor (02-06-05.02) (Page 128) ¹⁾	

¹⁾ Required for exponential device absolute calculation only.

Applications supported by SITRANS Probe LU240

Rectangular flume BS-3680

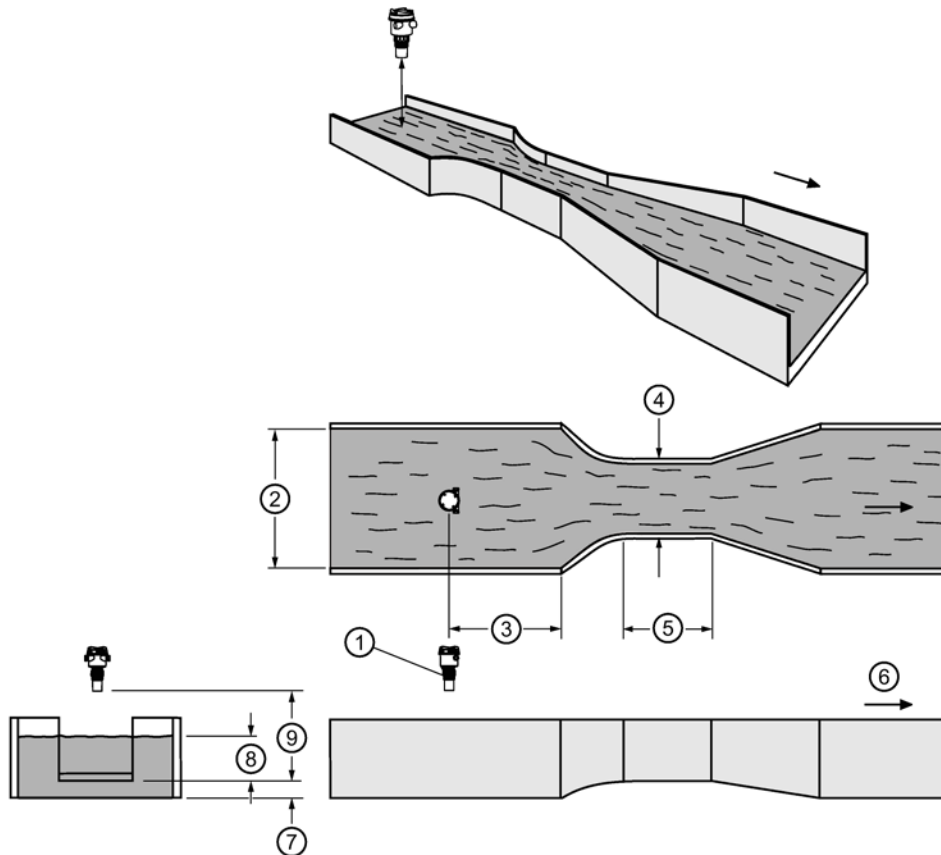

- ① SITRANS Probe LU240¹⁾
- ② 3 to 4 x level_{max}
- ③ Approach width
- ④ Throat width
- ⑤ Throat length
- ⑥ Direction of flow
- ⑦ Hump height
- ⑧ Level
- ⑨ Zero level

¹⁾ The device must be above the upper scaling point by at least the blanking value (Near range (03-01-02.01) (Page 133)).

Parameter	Value
Primary measuring device (02-06.01) (Page 124)	Rectangular flume BS-3680
PMD dimensions (M 02-06-05) (Page 126)	Approach width
	Throat width
	Hump height
	Throat length
Volume flow units (02-06.03) (Page 125)	
Method of flow calculation (02-06.02) (Page 125)	
Upper range value (02-04.05) (Page 120)	

Round nose horizontal crest weir BS-3680

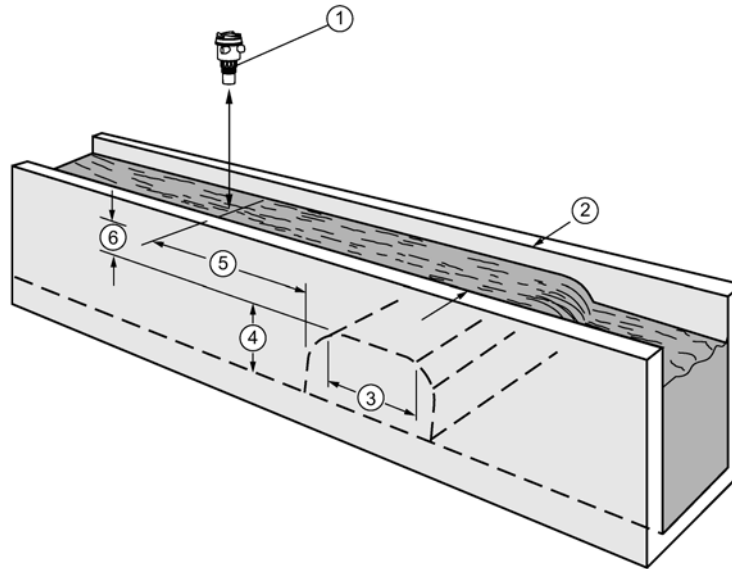

- ① Sitrans Probe LU240¹⁾
- ② Crest width
- ③ Crest length
- ④ Crest height
- ⑤ 3 to 4 x level_{max}
- ⑥ Level

¹⁾ The device must be above the upper scaling point by at least the blanking value (Near range (03-01-02.01) (Page 133)).

Parameter	Value
Primary measuring device (02-06.01) (Page 124)	Round nose horizontal crest weir BS-3680
PMD dimensions (M 02-06-05) (Page 126)	Crest width
	Crest height
	Crest length
Upper scaling point (02-05.05) (Page 124)	
Far range (03-01-02.02) (Page 133)	
Volume flow units (02-06.03) (Page 125)	
Method of flow calculation (02-06.02) (Page 125)	
Upper range value (02-04.05) (Page 120)	

Trapezoidal flume BS-3680

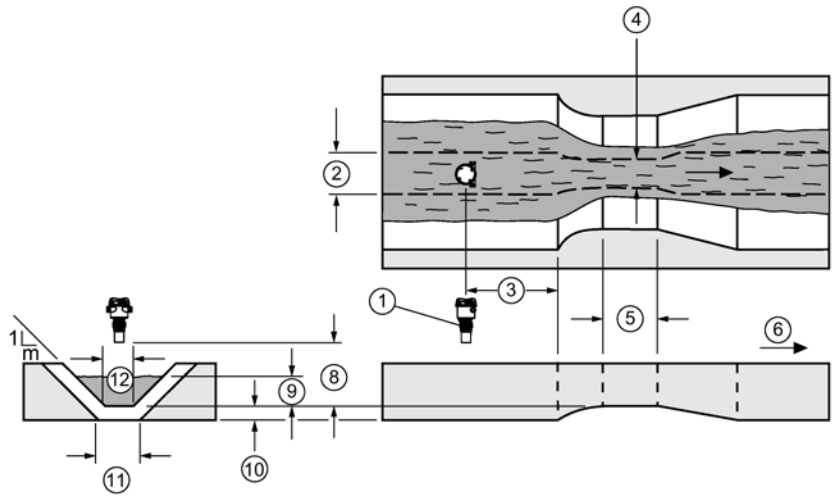

- ① SITRANS Probe LU240¹⁾
- ② Approach width
- ③ 3 to 4 x level_{max}
- ④ Throat width
- ⑤ Throat length
- ⑥ Direction of flow
- ⑧ Zero level
- ⑨ Level
- ⑩ Hump height
- ⑪ Approach width
- ⑫ Throat width

¹⁾ The device must be above the upper scaling point by at least the blanking value (Near range (03-01-02.01) (Page 133)).

Parameter	Value
Primary measuring device (02-06.01) (Page 124)	Trapezoidal flume BS-3680
PMD dimensions (M 02-06-05) (Page 126)	Slope
	Approach width
	Throat width
	Hump height
	Throat length
Upper scaling point (02-05.05) (Page 124)	
Far range (03-01-02.02) (Page 133)	
Volume flow units (02-06.03) (Page 125)	
Method of flow calculation (02-06.02) (Page 125)	
Upper range value (02-04.05) (Page 120)	

U-flume BS-3680

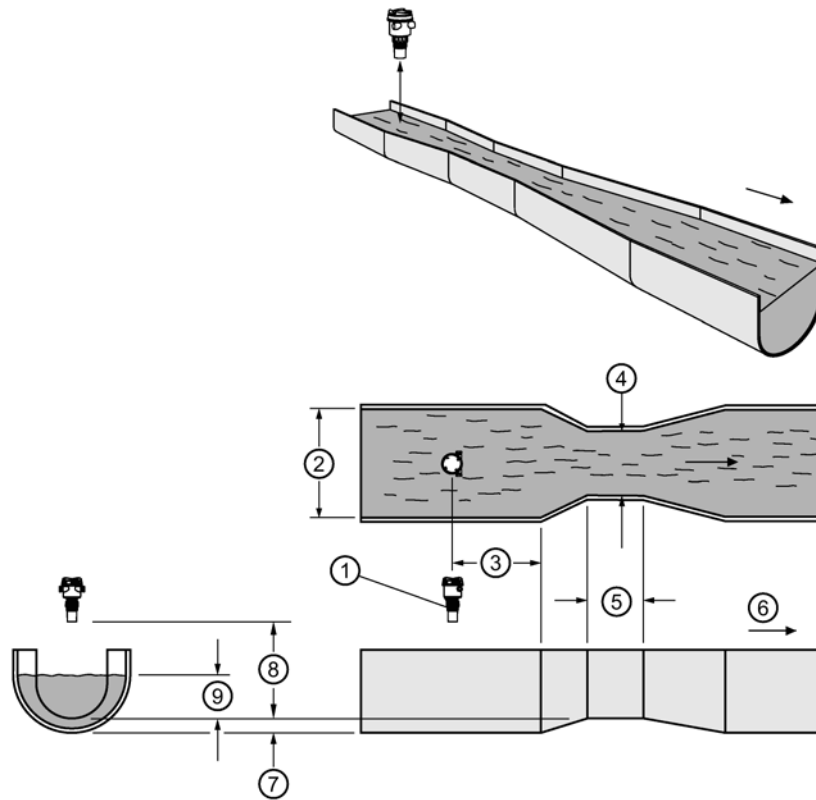

- ① SITRANS Probe LU240¹⁾
- ② Approach diameter
- ③ 3 to 4 x level_{max}
- ④ Throat diameter
- ⑤ Throat length
- ⑥ Direction of flow
- ⑦ Hump height
- ⑧ Zero level
- ⑨ Level

¹⁾ The device must be above the upper scaling point by at least the blanking value (Near range (03-01-02.01) (Page 133)).

Parameter	Value
Primary measuring device (02-06.01) (Page 124)	U-flume BS-3680
PMD dimensions (M 02-06-05) (Page 126)	Approach diameter
	Throat diameter
	Hump height
	Throat length
Upper scaling point (02-05.05) (Page 124)	
Far range (03-01-02.02) (Page 133)	
Volume flow units (02-06.03) (Page 125)	
Method of flow calculation (02-06.02) (Page 125)	
Upper range value (02-04.05) (Page 120)	

Finite crest weir BS-3680

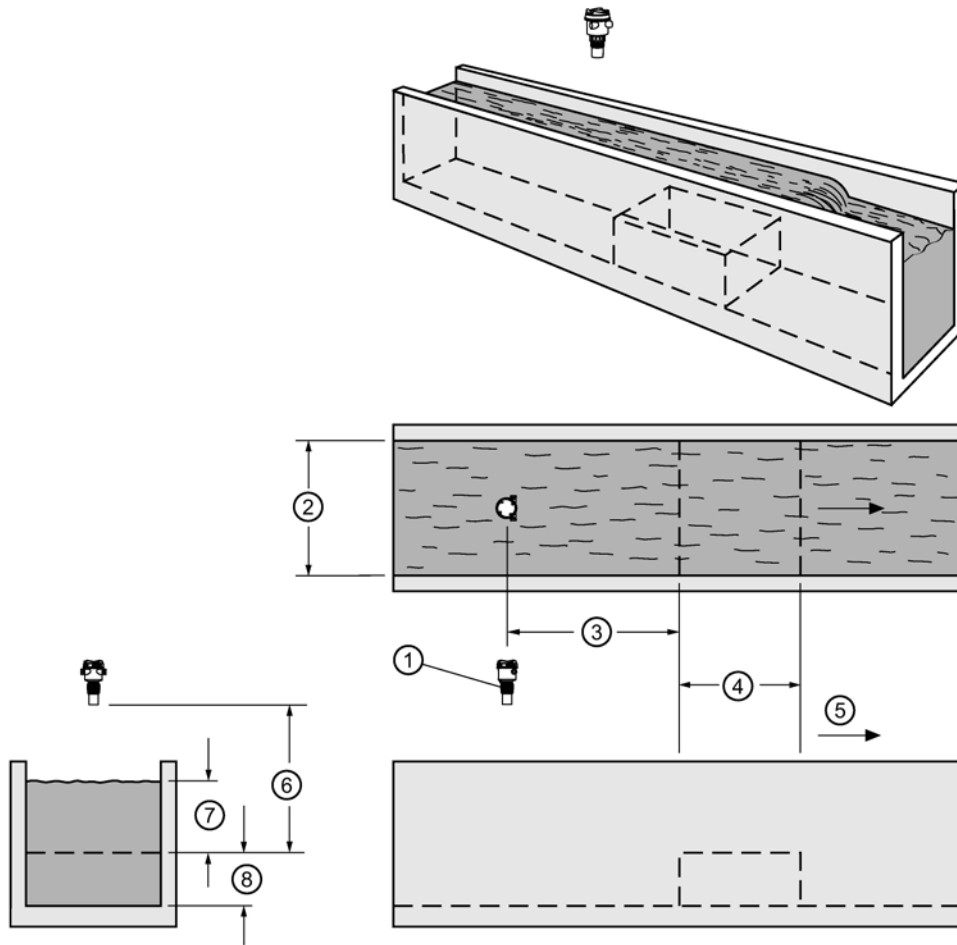

- ① SITRANS Probe LU240¹⁾
- ② Crest width
- ③ 3 to 4 x level_{max}
- ④ Crest length
- ⑤ Direction of flow
- ⑥ Zero level
- ⑦ Level
- ⑧ Crest height

¹⁾ The device must be above the upper scaling point by at least the blanking value (Near range (03-01-02.01) (Page 133)).

Parameter	Value
Primary measuring device (02-06.01) (Page 124)	Finite crest weir BS-3680
PMD dimensions (M 02-06-05) (Page 126)	Crest width
	Crest height
	Crest length
Upper scaling point (02-05.05) (Page 124)	
Far range (03-01-02.02) (Page 133)	
Volume flow units (02-06.03) (Page 125)	
Method of flow calculation (02-06.02) (Page 125)	
Upper range value (02-04.05) (Page 120)	

Thin plate rectangular weir BS-3680

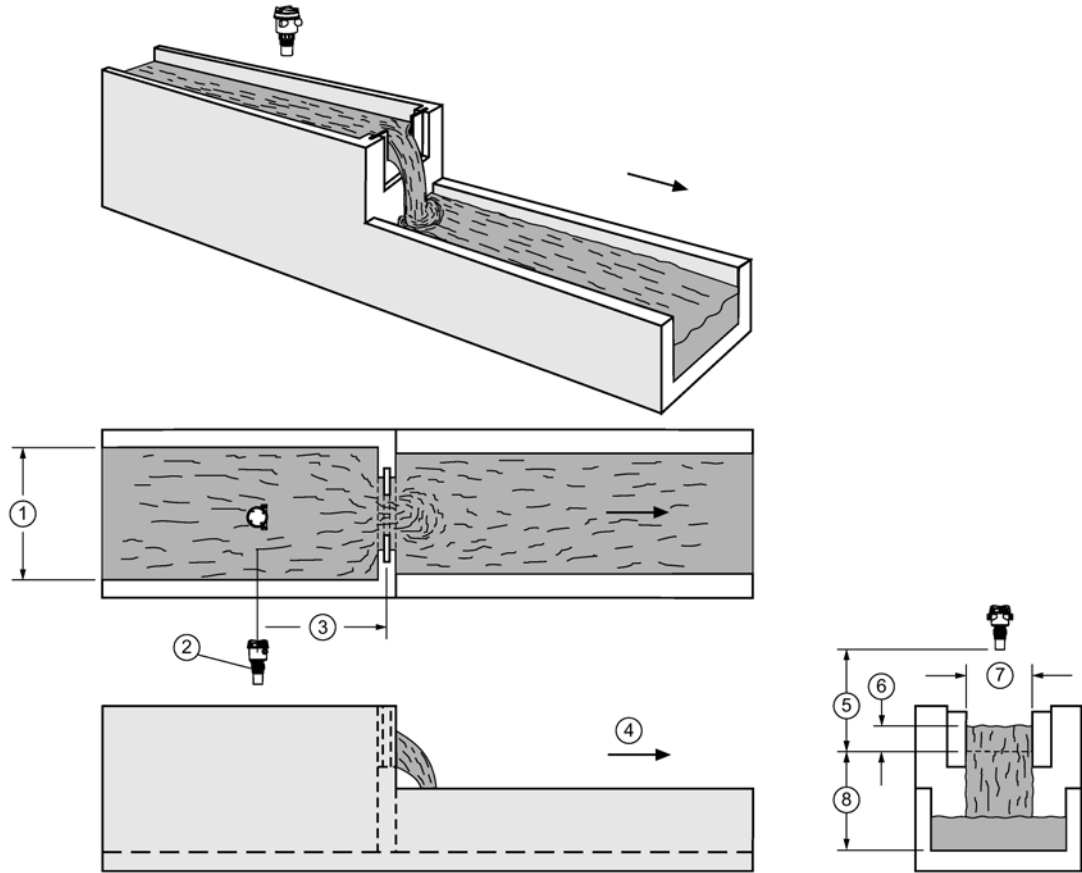

- ① Approach width
- ② SITRANS Probe LU240¹⁾
- ③ 4 to 5 x level_{max}
- ④ Direction of flow
- ⑤ Zero level
- ⑥ Level
- ⑦ Crest width
- ⑧ Crest height

¹⁾ The device must be above the upper scaling point by at least the blanking value (Near range (03-01-02.01) (Page 133)).

Parameter	Value
Primary measuring device (02-06.01) (Page 124)	Thin plate rectangular weir BS-3680
PMD dimensions (M 02-06-05) (Page 126)	Approach width
	Crest width
	Crest height
Upper scaling point (02-05.05) (Page 124)	
Far range (03-01-02.02) (Page 133)	
Volume flow units (02-06.03) (Page 125)	
Method of flow calculation (02-06.02) (Page 125)	
Upper range value (02-04.05) (Page 120)	

Thin plate V-notch weir BS-3680

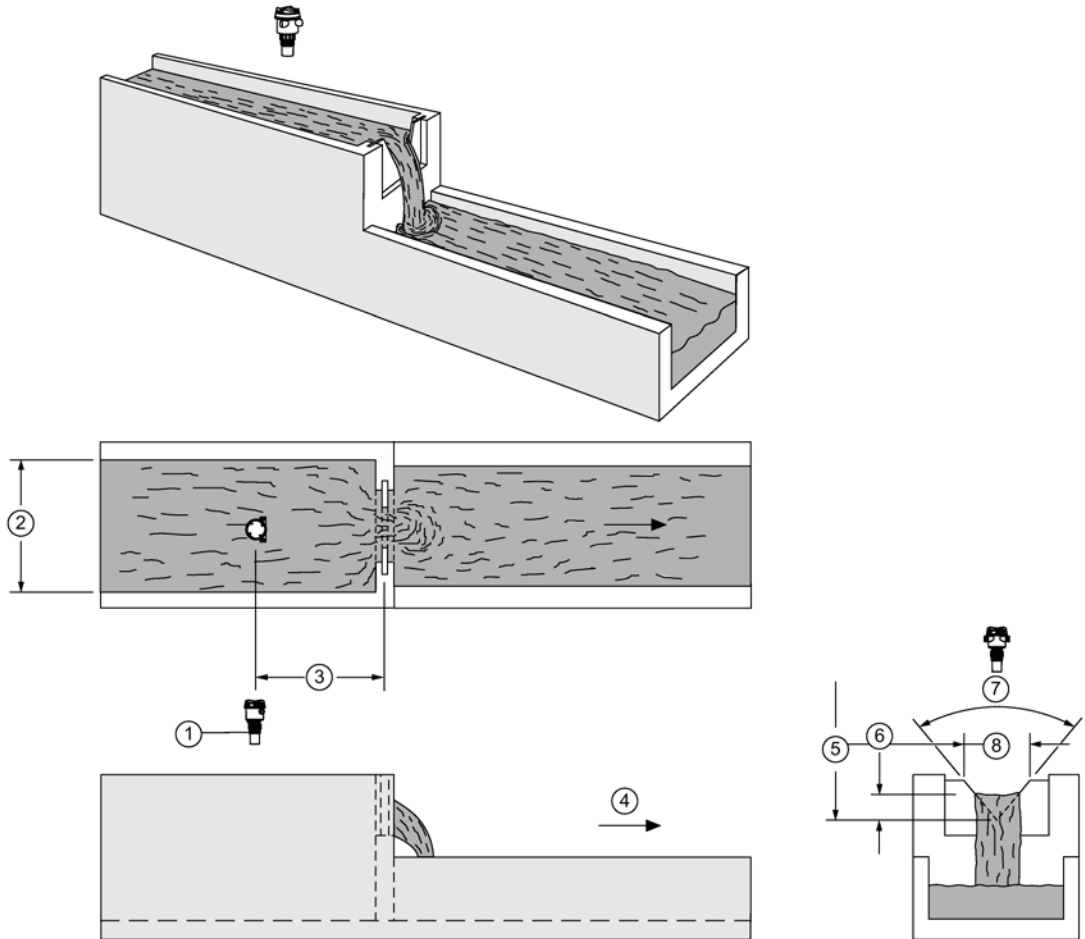

- ① SITRANS Probe LU240¹⁾
- ② Approach width
- ③ 4 to 5 x level_{max}
- ④ Direction of flow
- ⑤ Zero level
- ⑥ Level
- ⑦ V-notch angle
- ⑧ Crest width

¹⁾ The device must be above the upper scaling point by at least the blanking value (Near range (03-01-02.01) (Page 133)).

Parameter	Value
Primary measuring device (02-06.01) (Page 124)	Thin plate V-notch weir BS-3680
PMD dimensions (M 02-06-05) (Page 126)	V-notch angle
Upper scaling point (02-05.05) (Page 124)	
Far range (03-01-02.02) (Page 133)	
Volume flow units (02-06.03) (Page 125)	
Method of flow calculation (02-06.02) (Page 125)	
Upper range value (02-04.05) (Page 120)	

Rectangular weir contracted

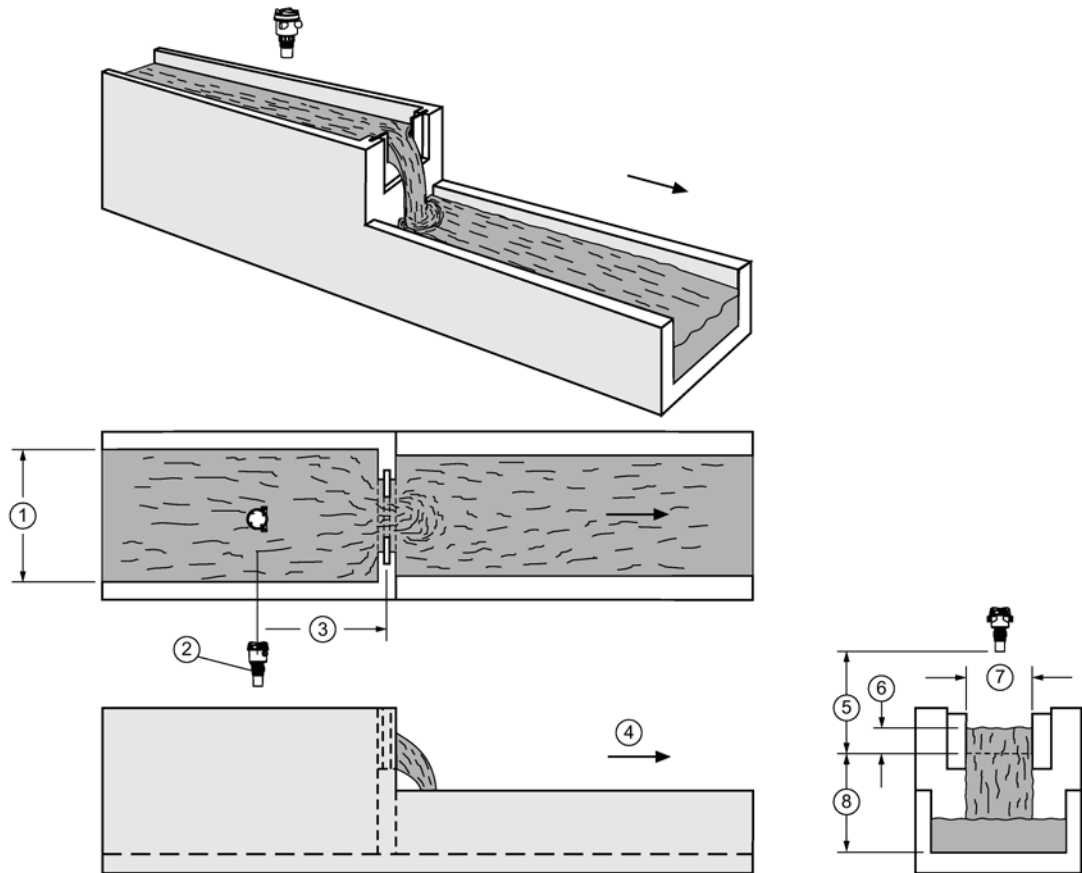

- ① Approach width
- ② Sitrans Probe LU240¹⁾
- ③ 4 to 5 x level_{max}
- ④ Direction of flow
- ⑤ Zero level
- ⑥ Level
- ⑦ Crest width
- ⑧ Crest height

¹⁾ The device must be above the upper scaling point by at least the blanking value (Near range (03-01-02.01) (Page 133)).

Parameter	Value
Primary measuring device (02-06.01) (Page 124)	Rectangular weir contracted
PMD dimensions (M 02-06-05) (Page 126)	Crest width
Upper scaling point (02-07.01) (Page 129)	
Far range (03-01-02.02) (Page 133)	
Volume flow units (02-06.03) (Page 125)	
Method of flow calculation (02-06.02) (Page 125)	
Upper range value (02-04.05) (Page 120)	

Round pipe flume

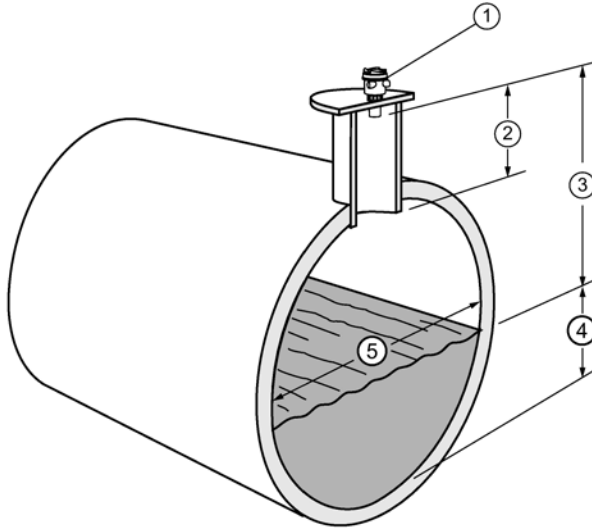

- ① SITRANS Probe LU240
- ② This dimension should be at least 15 cm (6") shorter than the blanking value (see Near range (03-01-02.01) (Page 133))
- ③ The transducer must be above the upper scaling point by at least the blanking value.
- ④ Level
- ⑤ Pipe diameter

Parameter	Value
Primary measuring device (02-06.01) (Page 124)	Round pipe
PMD dimensions (M 02-06-05) (Page 126)	Pipe diameter
	Slope (fall/run)
	Roughness coefficient
Upper scaling point (02-05.05) (Page 124)	
Far range (03-01-02.02) (Page 133)	
Volume flow units (02-06.03) (Page 125)	
Method of flow calculation (02-06.02) (Page 125)	
Upper range value (02-04.05) (Page 120)	

Palmer-Bowlus flume

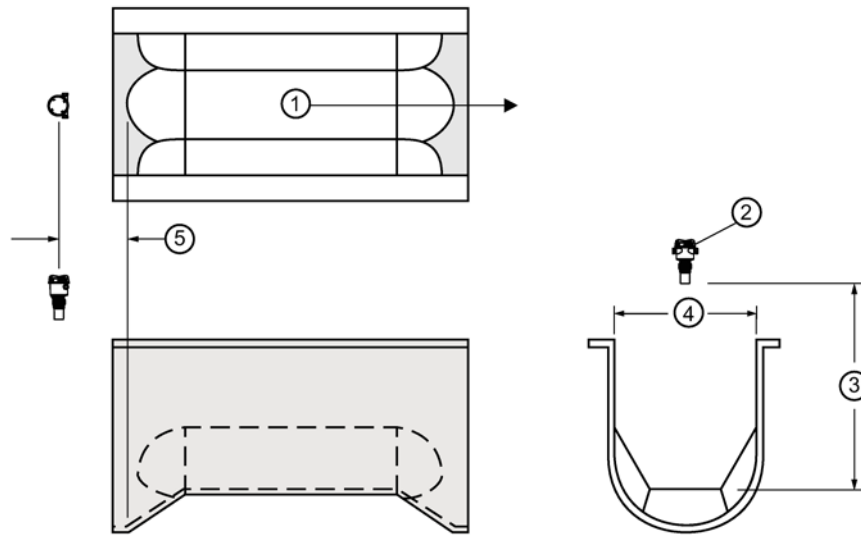

- ① Direction of flow
- ② SITRANS Probe LU240¹⁾
- ③ Zero level
- ④ Pipe diameter
- ⑤ (Pipe diameter)/2, point of measurement²⁾

¹⁾ The device must be above the upper scaling point by at least the blanking value (Near range (03-01-02.01) (Page 133)).

²⁾ For rated flows under free flow conditions

Parameter	Value
Primary measuring device (02-06.01) (Page 124)	Palmer-Bowlus flume
PMD dimensions (M 02-06-05) (Page 126)	Maximum flume width
Upper scaling point (02-05.05) (Page 124)	
Upper range value (02-04.05) (Page 120)	
Volume flow units (02-06.03) (Page 125)	
Method of flow calculation (02-06.02) (Page 125)	Ratiometric

Note

Method of flow calculation

The Palmer-Bowlus flume can only be set up using ratiometric calculations.

Application information

- Sized by pipe diameter
- Flume relief is trapezoidal
- Designed to install directly into pipelines and manholes
- Level is referenced to bottom of the throat, not bottom of the pipe
- For rated flows under free flow conditions, the level is measured at a distance equal to (Pipe diameter)/2 upstream from the beginning of the converging section.

H-flume

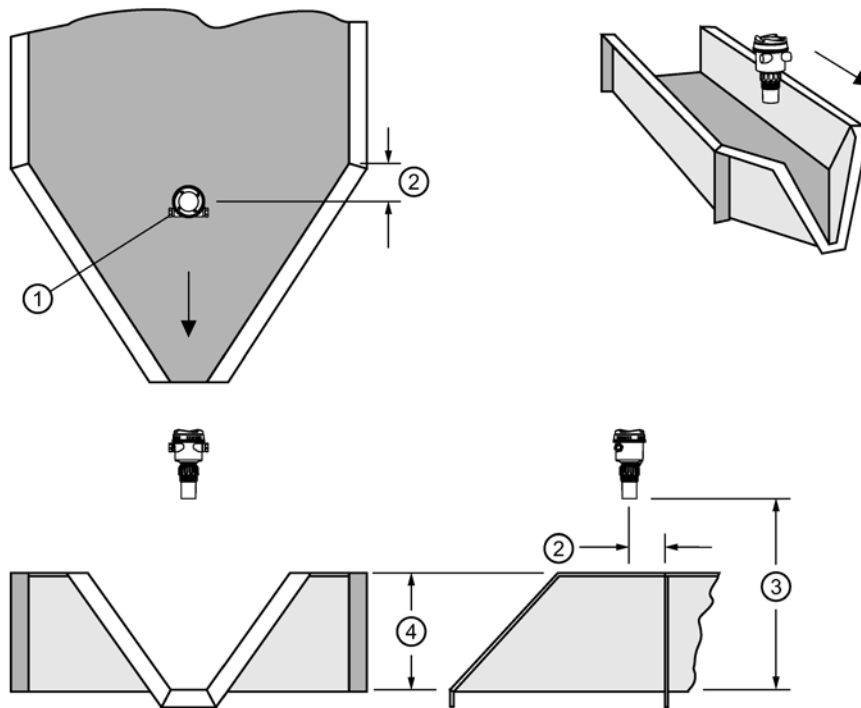

- ① SITRANS Probe LU240¹⁾
- ② Point of measurement
- ③ Zero level
- ④ Flume height

¹⁾ The device must be above the upper scaling point by at least the blanking value (Near range (03-01-02.01) (Page 133)).

Note

Method of flow calculation

H-flume can only be set up using ratiometric calculations.

Parameter	Value
Primary measuring device (02-06.01) (Page 124)	H-flume
Flow exponent (02-06-05.01) (Page 127)	Flume height
Upper scaling point (02-05.05) (Page 124)	
Upper range value (02-04.05) (Page 120)	
Volume flow units (02-06.03) (Page 125)	
Method of flow calculation (02-06.02) (Page 125)	Ratiometric

Application information

- Sized by maximum depth of flume
- Approach is preferably rectangular, matching width and depth for distance 3 to 5 times the depth of the flume.
- For rated flows under free flow conditions, the level is measured at a point downstream from the flume entrance. Refer to the following table.

Flume size diameter in feet	Point of measurement	
	cm	inches
0.5	5	1.75
0.75	7	2.75
1.0	9	3.75
1.5	14	5.5
2.0	18	7.25
2.5	23	9
3.0	28	10.75
4.5	41	16.25

- H-flumes come with a flat or sloping floor. The same flow table can be used because error is less than 1%.

Custom calculation support

When the primary measuring device (PMD) does not fit one of the standard types, it can be configured using a custom characterization. Define your PMD using Custom (M 02-07) (Page 129).

For this curve, both level and volume flow breakpoints (X-value, Y-value, up to 32) are entered to define the flow. The device supports a linear flow calculation shown in the following chart. (The method of flow calculation for custom support can be ratiometric or absolute. Refer to your PMD manufacturer's documentation.)

Typical flow characterization

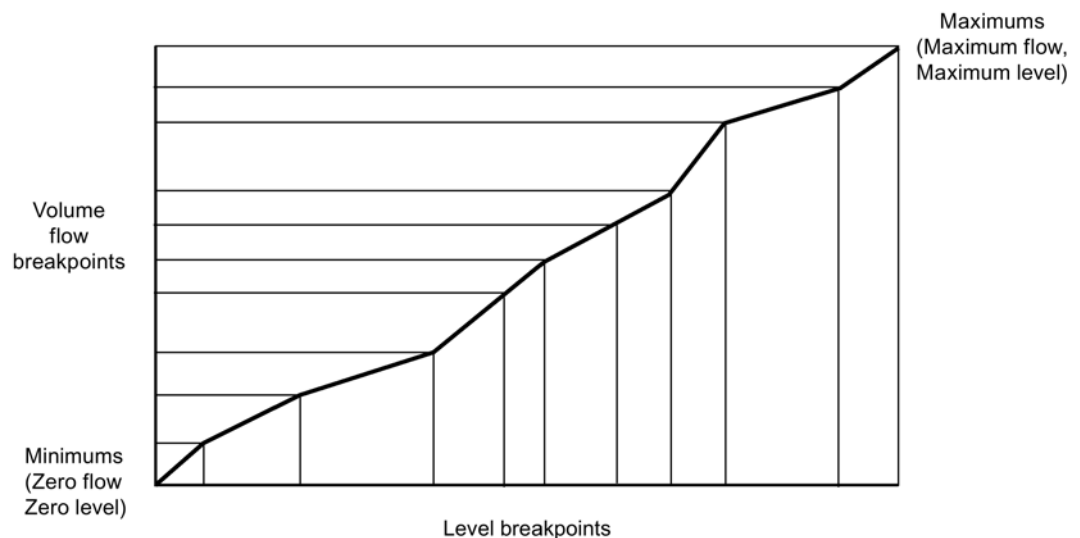

Characterization is achieved by entering the level and corresponding volume flow breakpoints, either from empirical measurement or from the manufacturer's specification. Increasing the number of defined breakpoints will increase the accuracy of the volume flow measurement.

Breakpoints should be concentrated in areas exhibiting the higher degrees of nonlinear flow. A maximum of 32 breakpoints can be defined, with a minimum of four required. The curve's end point is always specified by parameter "Upper scaling point", for maximum volume or maximum flow. ("Upper scaling point" is set by parameter "Upper range value" in "Quick commissioning wizard".)

This parameter value is in addition to the 32 breakpoints available for definition.

Use as many breakpoints as required by the complexity of your PMD. For more information, refer to Characterization chart (Page 101).

Example flumes

These example flumes would both require a custom calculation using a characteristic curve.

Trapezoidal flume

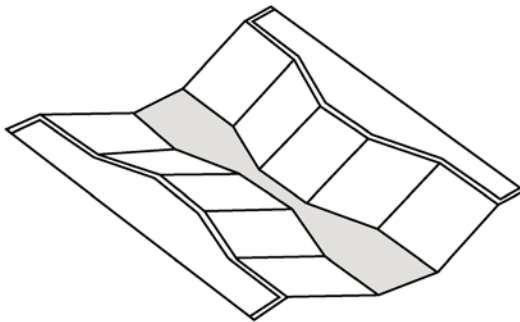

Dual range (nested) Parshall

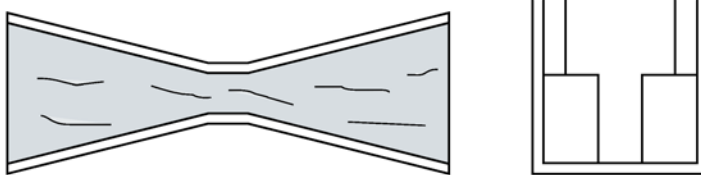

Example weir profiles

These weirs could require a custom calculation using a characteristic curve.

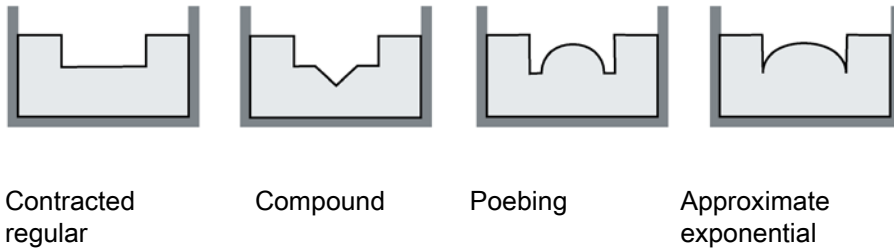

8.1.6 Custom application

8.1.6.1 Characterization chart

Regardless of whether you wish to measure volume or volume flow, if you cannot use a pre-defined vessel (Vessel shape (02-05.01) (Page 121)) or PMD (Primary measuring device (02-06.01) (Page 124)), you must configure a custom application.

Configure a custom application by setting parameter "Operation" (in quick commissioning wizard), or "PV selection" (in **navigation view**) to option "Custom", then define your vessel/PMD using Custom (M 02-07) (Page 129).

Up to 32 breakpoints, each consisting of an input and output value (X- and Y-value), are available to define your vessel shape/PMD.

- For a custom volume characteristic curve, X-values refer to level, Y-values refer to volume.
- For a custom volume flow characteristic curve, X-values refer to level, Y-values refer to volume flow.

8.1 Operating instructions

1. Plot a chart. Usually a vessel supplier will provide this chart. However, if you have a custom-built vessel/PMD, then you will need access to complete drawings, or accurate measurements.
2. Enter the curve values from this chart using "X-value n", "Y-value n" breakpoints, where 'n' is the breakpoint number 1 to 32.

Note

If breakpoints are entered via local display, then an upload is performed via SIMATIC PDM, a second upload via PDM may be necessary to transfer the breakpoint values.

3. Ensure extra points are added around sharp transitions in the vessel/PMD (e.g: steps in a vessel wall).

Note

The end points in the curve are 0,0 (fixed), and the point defined by parameter "Upper scaling point" for maximum volume or maximum flow. ("Upper scaling point" is set by parameter "Upper range value" in "Quick commissioning wizard".)

Example chart for custom volume characterization (with 15 of possible 32 breakpoints defined):

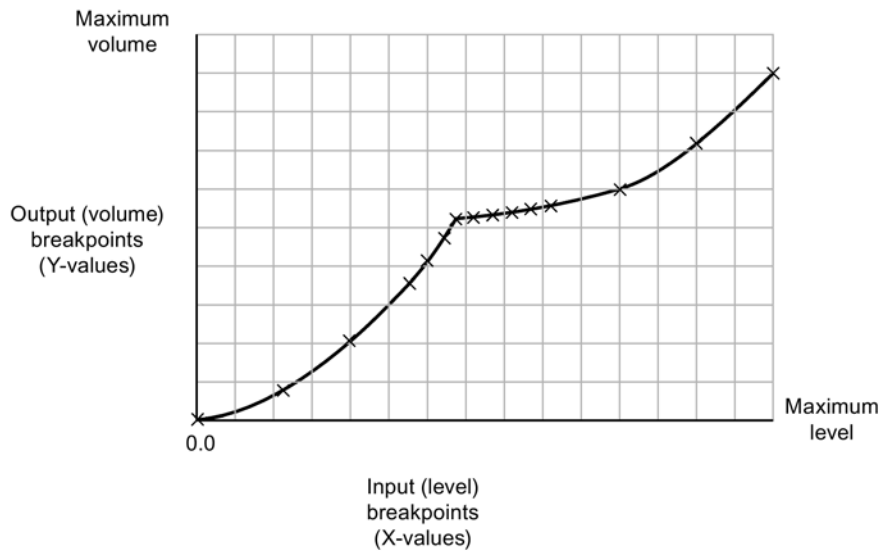

Parameter	Value	Description
X-value 1	0.0	Determines the level break-points at which the volume breakpoints are known.
X-value 2	0.8	
X-value 3	2.0	
X-value 4	3.5	
X-value 5	4.1	
X-value 6	4.7	
X-value 7	5.1	
X-value 8	5.2	
X-value 9	5.3	
X-value 10	5.4	
X-value 11	5.5	
X-value 12	5.6	
X-value 13	6.0	
X-value 14	7.2	
X-value 15	9.0	

Parameter	Value	Description
Y-value 1	0.0	Determines the volume break-points which correspond to the level breakpoints.
Y-value 2	2.1	
Y-value 3	4.0	
Y-value 4	5.6	
Y-value 5	5.9	
Y-value 6	6.3	
Y-value 7	6.7	
Y-value 8	7.1	
Y-value 9	7.8	
Y-value 10	8.2	
Y-value 11	8.8	
Y-value 12	9.2	
Y-value 13	10.9	
Y-value 14	13.0	
Y-value 15	15.0	

For more details regarding characterization, refer to Volume calculation (Page 196), or Volume flow calculation (Page 198).

8.1.7 Simulation

Process values, loop current, and diagnostics can be simulated with this device. Loop current can be simulated via the HMI, or via an engineering system, such as SIMATIC PDM. Process values and diagnostics can be simulated via a remote engineering system.

Current output simulation

The current output can also be simulated using Loop test wizard (03-03.01) (Page 141).

A simulated value (from a preset selection, or a value set by customer) can be set to test the functioning of the mA connections during commissioning or maintenance of the device. The range is 3.55 mA to 22.8 mA.

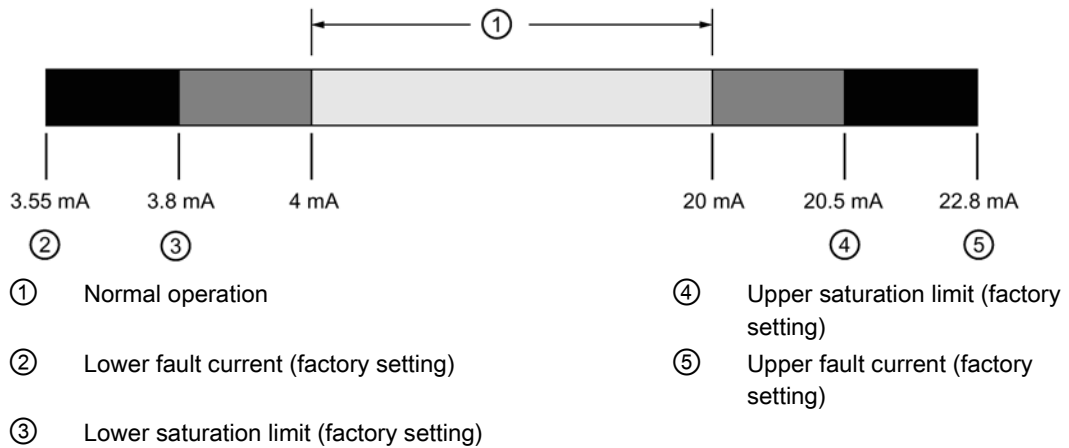

Note

Simulated current output

The simulated current output value influences output to the control system.

In general, to simulate current output:

1. Run the "Loop test wizard" from the menu "Maintenance and diagnostics > Loop test" on the device (or from the **Device** menu in SIMATIC PDM).
 - Select a preset mA value, or enter a custom value. (Custom value can be entered by selecting "User" option on device, or "Other" option in PDM.)
2. Start the loop test.
3. When you are ready to end the simulation, stop the loop test by exiting the wizard. The device returns to the actual output value.

Process value simulation

Process value simulation is an iterative process whereby parameters are adjusted and corresponding results are displayed. Process values can only be simulated using a remote engineering system, but when a simulation is active, it will be represented by the fault code "Cb" and corresponding symbol appearing on the device display.

Note

Simulation enabled

- Simulation fault code "Cb" will show on local display even if other faults are present.
- Simulation fault code and corresponding symbol are shown with a cyan background in the EDD.

When Simulation is enabled, some of the device's configured functionality will respond to the simulated value, including:

- **Limit monitoring:** Any warnings and process alarms that have been configured, will activate based on the simulated value.
- **Logging:** Log files will reflect the simulated values.
- **Milliamp output:** The loop current output will also track the corresponding process value it has been configured to read.

The following function will not respond to the simulated value when simulation is enabled:

- **Fault conditions:** The device will never enter the fail-safe state when in simulation mode. Faults that would normally cause a fail-safe condition (such as a broken cable) may still occur, but a fail-safe condition will not be reported on the device during simulation.

In general, to simulate a process value via PDM:

1. Go to the **Device** menu in PDM, and choose "**Simulation > Process values**". (For parameter details, see Simulation (Page 216)).
2. Set a simulation mode.
3. Set simulation value, and any parameters for a ramp simulation.
4. Start simulation (click "Transfer" button).

(The status of the simulation can be monitored in the PDM menu "**View > Process values**".)

To stop simulation at any time, change parameter "Simulation mode" to "Disabled".

Simulating a fixed process value

1. Set parameter "Simulation mode" to "Enabled" to simulate a **fixed** process value.
2. Set parameter "Simulation value" to the desired fixed value for the simulation.
3. Set parameter "PV status" to the status to simulate.
4. Click "Transfer" button to start the simulation.
5. Set parameter "Simulation mode" to "Disabled" to stop the simulation.

Simulating a changing process value

1. Set parameter "Simulation mode" to "Ramp" to simulate a changing process value.
2. Set parameter "Simulation value" to the desired starting value for the simulation.
3. Set parameter "PV status" to the status to simulate.
4. Set parameter "Ramp end" to stop the simulation when the process value reaches the ramp end value.
5. Set parameter "Ramp steps" to set the number of steps in the ramp simulation.
6. Set parameter "Ramp duration" to set the time interval (in seconds) for each step in the simulation.
7. Click button "Transfer" to start the simulation.

The simulated level will initially begin ramping up from the simulation value. When the process value rises to 100% or falls to 0%, it reverses direction at the same rate. The

simulation will stop based on the ramp end value, but ensure parameter "Simulation mode" is set to "Disabled" before the current output is returned to automatic control.

Simulation timeout

Simulation will automatically be disabled and the device will return to normal measurement ten minutes after changing (editing) any simulation parameter (except parameter "Simulation value"). When the timeout occurs, parameter "Simulation mode" switches to "Disabled", and the fault code "Cb" will no longer show on the local display. (Device status conditions will also reset in PDM, AMS, FDT, and FC375/475.)

Application test

You can test the application by varying the actual process value (the preferred test method), or by simulating changes to the process value.

When simulating a changing process value, run a complete cycle to verify that device operates as expected. Monitor system performance carefully, under all anticipated operating conditions.

1. When the device performs exactly as required, programming is complete.
2. If alternate measurement units, or fail-safe action is desired, update the parameters for the new functionality.
3. If you experience problems with system performance, see Diagnosing and troubleshooting (Page 161).

If you cannot observe all possible operating conditions by varying the process value, use the simulation process above to verify programming.

Retest the system each time you adjust any parameters.

Diagnostic simulation

Diagnostics can be simulated via a remote engineering system. Diagnostics related to "Device status", "Limit monitoring and event counter", and "HART status" can be chosen from a select list to simulate.

In general, to simulate diagnostics via PDM:

1. Go to the menu "Device" in PDM and choose "Simulation > Diagnostics".
2. On the tab "Diagnostics simulation", click button "Enable" (button toggles between "Enable" and "Disable") to put the device in simulation mode.
3. Select the diagnostics to simulate from the drop-down list provided for the "Diagnostics" field.
4. For each diagnostic selected, set the "Action" to be simulated: "On" or "Off".
5. Start simulation (click "Transfer" button).

The status of the simulation for each diagnostic selected, can be seen on the remaining tabs in the dialogue window. The diagnostic being simulated will show a checked box.

End simulation on the tab "Diagnostics simulation":

- To end simulation of a specific diagnostic, click the button "Enable/Disable Simulation" (below the "Action" field).
- To stop device simulation at any time, click the toggle button at the top of the window from "Enable" to "Disable".

8.1.8 Communication system

SITRANS Probe LU240 is a transmitter capable of communicating process information to a Supervisory Control and Data Acquisition (SCADA) system, via a HART modem.

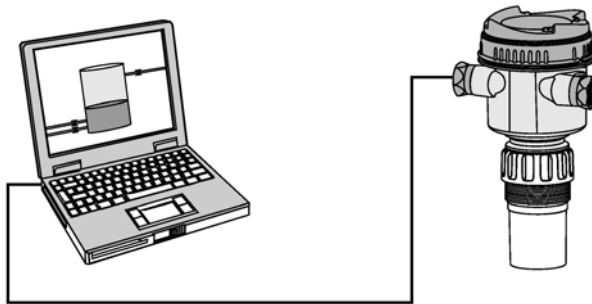

Further information can be found in HART communication (Page 205).

Parameter assignment - Local

This chapter includes all parameters accessible via local operation.

Parameters are identified by name (followed by parameter number in parenthesis), and organized into function groups within a menu structure.

See HMI menu structure (Page 245) for a list of abbreviated parameter names, as they appear on the device.

Note

- In Navigation view, local buttons (▲ ▼ ▶ ◀) navigate in the direction of the arrow.
 - Press ▶ button to open **Edit Mode**, or to save a modification.
-

For other parameters accessible only via an engineering system (such as SIMATIC PDM, or AMS Device Manager), see Parameter assignment - Remote (Page 147).

9.1 Quick start (M 01)

From **measurement view**, press ▶ button to enter **parameter view**, then press ▼ button to select the "Quick commissioning wizard". Press ▶ button to open the first step, and follow the instructions.

Note

Do not use a quick commissioning wizard to modify individual parameters. (Perform customization for your application only *after* "Quick commissioning wizard" has been completed).

- See Quick commissioning via HMI (Page 47).
- See Quick commissioning via SIMATIC PDM (Page 214).

9.1.1 Quick commissioning (01-01)

Provides step-by-step procedure to set up common applications easily.

9.1.2 AFES wizard (01-02)

Used to prevent false echo detection over a specified range.

9.2 Setup (M 02)

The following parameters relate to device setup.

9.2.1 Select output (M 02-01)

9.2.1.1 PV selection (02-01.01)

Sets the primary variable by selecting a process value that corresponds to the loop current.

Setting	Level	LEVEL
	Space	SPACE
	Distance	DIST
	Volume	VOL
	Volume flow	VFLOW
	Custom	CUSTM
Default	Distance	DIST

Note

Start view set automatically by wizard

The process value to display on device after power on is set automatically by the "Quick commissioning wizard".

- When parameter "Operation" is set in the wizard, the value is written to parameter "Start view".
 - If a change is made to parameter "Start view" or parameter "PV selection" after running the wizard, the last one set will apply.
 - Options "Volume", "Volume flow", and "Custom" are not visible in **measurement view** until configured. If one of these unconfigured options is selected in parameter "Start view", **measurement view** will show the next visible process value.
-

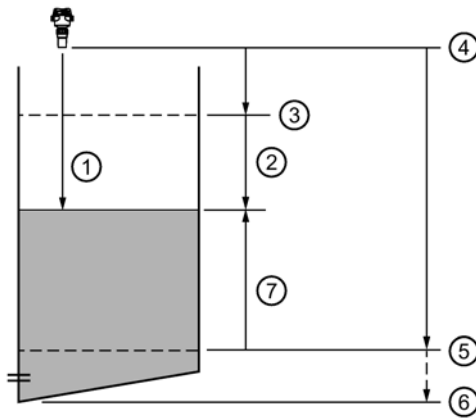

- ① Distance
- ② Space
- ③ Upper calibration point
- ④ Sensor reference point
- ⑤ Lower calibration point
- ⑥ Far range
- ⑦ Level

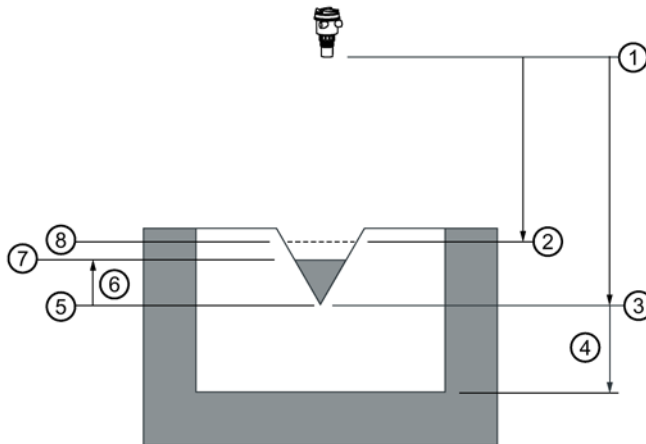

- ① Sensor reference point
- ② Upper calibration point
- ③ Lower calibration point
- ④ Far range
- ⑤ Zero level (head)
- ⑥ Level (head)
- ⑦ Material surface
- ⑧ Upper scaling point (maximum volume/flow)

Option	Description	Reference point
Level	Distance to material surface	Lower calibration point (process empty level)
Space	Distance to material surface	Upper calibration point (process full level)
Distance	Distance to material surface	Sensor reference point
Volume	Volume of material in Volume units (based on level)	Lower calibration point
Volume flow	Flow rate in an open channel in Volume flow units	Zero level, zero flow

9.2.1.2 SV selection (02-01.02)

Sets a process value as secondary variable.

Setting	Level	LEVEL
	Space	SPACE
	Distance	DIST
	Volume	VOL
	Volume flow	VFLOW
	Custom	CUSTM
	Sensor temperature	STEMP
Default	Sensor temperature	STEMP

9.2.1.3 Linearization type (02-01.03)

Sets type of linearization used to calculate volume or volume flow.

Setting	None	NONE
	Volume	VOL
	Volume flow	VFLOW
	Custom	CUSTM
Default	None	NONE

9.2.2 Sensor (M 02-02)

9.2.2.1 Units (02-02.01)

Sets measurement units used.

			Default
Setting	Meters	m	3 decimal places
	Centimeters	cm	1 decimal place
	Millimeters	mm	0 decimal places
	Feet	Ft	3 decimal places
	Inches	in	2 decimal places
Default	Meters	m	3 decimal places

Note

Dynamic decimal places

Each setting for parameter "Units" has a default number of decimal places used to show the process value on the local display. However, if the value is too large to show on the segment display, the decimal places will be automatically adjusted to show the process value.

Note**Process value too large to display**

In some cases, even with dynamic decimal places, it is possible that the process value be too large to show on the local display, "#####" will show instead.

If this occurs in a typical application:

- Adjust parameter "Units" so that a smaller value can be shown, e.g. use meters instead of millimeters.

If this occurs in a custom application:

- Adjust parameter "Custom units" so that a smaller value can be shown, e.g. use tons instead of pounds.
- Note that a change to custom units also requires a scaling adjustment (see Upper range value (02-04.05) (Page 120)).

Custom units can only be defined via remote operation (see Custom units (Page 150)).

9.2.2.2 Fill rate (02-02.02)

Sets the maximum fill rate the device can track. Used to enhance the process value damping.

Enter a value slightly greater than the vessel's maximum filling rate.

Setting	0 to 99999
Default	0.1 m/min

Note**Rate parameters**

The three rate parameters "Fill rate", "Empty rate", and "Damping value" work in conjunction, and are affected by parameter "Response rate" (set in the quick commissioning wizard).

The rate parameters automatically adjust when parameter "Response rate" is altered, but any changes made to the rate parameters following the completion of the wizard will supersede the response rate setting.

9.2.2.3 Empty rate (02-02.03)

Sets the maximum empty rate the device can track. Used to enhance the process value damping.

Enter a value slightly greater than the vessel's maximum emptying rate.

Setting	0 to 99999
Default	0.1 m/min

Note

Rate parameters

The three rate parameters "Fill rate", "Empty rate", and "Damping value" work in conjunction, and are affected by parameter "Response rate" (set in the quick commissioning wizard).

The rate parameters automatically adjust when parameter "Response rate" is altered, but any changes made to the rate parameters following the completion of the wizard will supersede the response rate setting.

9.2.3 Calibration (M 02-03)

9.2.3.1 Auto sound velocity wizard (02-03.01)

Used to adjust the speed of sound, based on an actual measurement, to change the distance value.

Note

Wizard operation requires 22.5 mA

Device output will read 22.5 mA during wizard operation. When wizard completes, device output will return to normal behavior.

Via SIMATIC PDM, go to menu "**Device > Auto sound velocity wizard**".

Conditions for use of this feature:

- The acoustic beam atmosphere is other than air
- The acoustic temperature is unknown
- The reading accuracy is acceptable at higher material levels only

For best results, calibrate with the level at a known value near low calibration point.

Using Auto sound velocity

Start with a steady distance at a known high distance value (high distance value equates to a low level value).

1. Review the distance measurement via local display for approximately 30 seconds to verify repeatability.
2. Measure the actual distance (for example, with a tape measure).
3. Enter the actual distance, defined in parameter "Units".

Repeat this procedure if the atmosphere type, concentration, or temperature conditions are different from when the last sound velocity calibration was performed.

Actual distance

The true measurement that the user has measured in vessel.

Setting	<ul style="list-style-type: none"> • 0 to 6 m (6 meter device) • 0 to 12 m (12 meter device)
Default	0

Confirm

Applies settings as last step in wizard.

Setting	Yes. Wizard completes and settings are applied.	YES
	No. Returned to start of wizard. (Settings are saved to perform wizard again, but not applied until "Confirm" set to "YES".)	NO
Default	No	NO

9.2.3.2 Sensor offset wizard (02-03.02)

Used to calculate sensor offset, based on an actual measurement, to change the distance value.

Note**Wizard operation requires 22.5 mA**

Device output will read 22.5 mA during wizard operation. When wizard completes, device output will return to normal behavior.

Via SIMATIC PDM, go to menu "**Device > Sensor offset wizard**".

Actual distance

The true measurement that the user has measured in vessel.

Setting	<ul style="list-style-type: none"> • 0 to 6 m (6 meter device) • 0 to 12 m (12 meter device)
Default	0

Confirm

Applies settings as last step in wizard.

Setting	Yes. Wizard completes and settings are applied.	YES
	No. Returned to start of wizard. (Settings are saved to perform wizard again, but not applied until "Confirm" set to "YES".)	NO
Default	No	NO

9.2.3.3 Lower calibration point (02-03.03)

Sets distance from sensor reference point to lower calibration point: usually process empty level.

Setting	<ul style="list-style-type: none"> • 0 to 6 m (6 m device) • 0 to 12 m (12 m device)
Default	<ul style="list-style-type: none"> • 6 m (6 m device) • 12 m (12 m device)

Defined in parameter "Units".

9.2.3.4 Upper calibration point (02-03.04)

Sets distance from sensor reference point to upper calibration point: usually process full level.

Setting	<ul style="list-style-type: none"> • 0 to 6 m (6 m device) • 0 to 12 m (12 m device)
Default	0 m

Defined in parameter "Units".

9.2.3.5 Lower level point (02-03.05)

Sets level value when material is at lower calibration point.

Setting	-99999 to 99999 m
Default	0

9.2.3.6 Upper level point (02-03.06)

Sets level value when material is at upper calibration point.

Setting	-99999 to 99999 m
Default	<ul style="list-style-type: none"> • 6 m (6 m device) • 12 m (12 m device)

9.2.3.7 Sensor offset (02-03.07)

Sets offset to compensate for changes in sensor reference point.

Changes to sensor reference point may result from adding a thicker gasket or reducing the standoff/nozzle height.

Setting	-99.999 to 99.999 m
Default	0

If amount of parameter "Sensor offset" is known, enter the constant that can be added to or subtracted from sensor value¹⁾ to compensate if the sensor reference point has shifted.

¹⁾ The value produced by the echo processing which represents the distance from sensor reference point to the target

9.2.3.8 Sound velocity (02-03.08)

Displays calculated velocity at measured temperature of medium.

Units displayed in meters per second (m/s).

9.2.3.9 Sound velocity (20 °C) (02-03.09)

Sets velocity of sound in medium at 20 °C.

Setting	0
Default	344.13 m/s

If the acoustic beam atmosphere sound velocity at 20 °C (68 °F) is known, and the sound velocity vs. temperature characteristics are similar to that of air (344.1 m/s), enter the sound velocity. Units displayed in meters per second (m/s).

9.2.3.10 Short shot frequency (02-03.10)

Sets short shot transmit pulse frequency, in kHz.

Setting	40000 to 75000 Hz
Default	54000 Hz

9.2.3.11 Long shot frequency (02-03.11)

Sets the long shot transmit pulse frequency, in kHz.

Setting	40000 to 75000 Hz
Default	54000 Hz

9.2.3.12 Low-level cutoff (02-03.12)

Sets lower limit on measured value (before any offset applied).

For example, set value to zero to prevent a negative level measurement.

Setting	0
Default	-999 m

9.2.4 Current output (M 02-04)

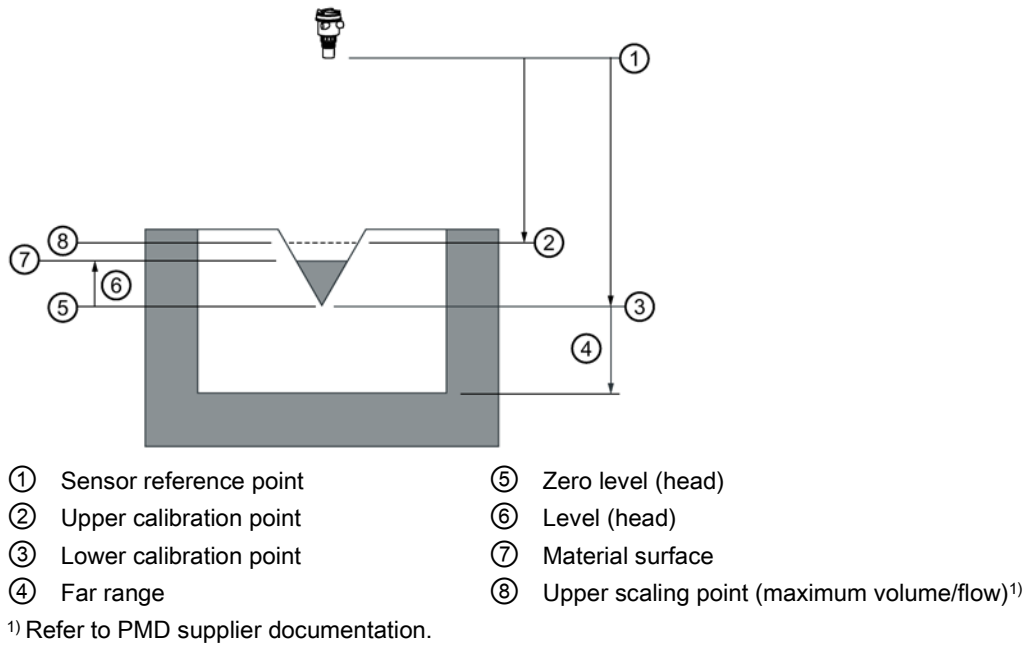
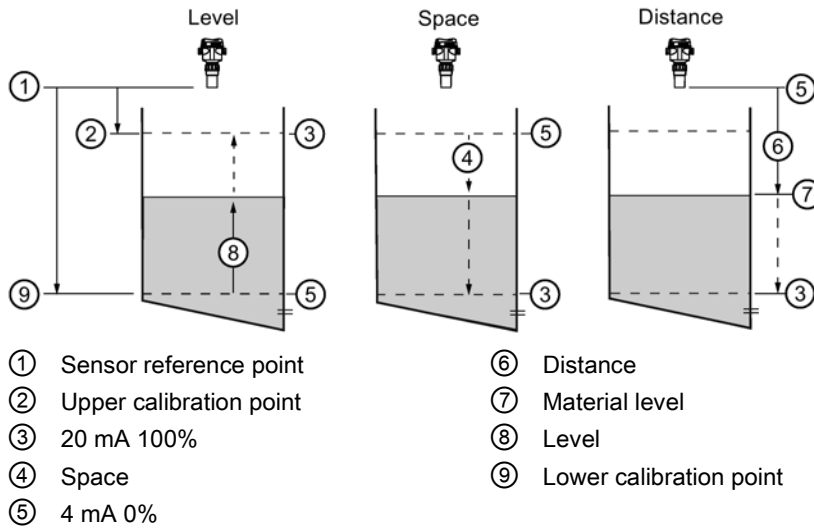

9.2.4.1 Loop current mode (02-04.01)

Sets operation of Loop current for HART multidrop mode.

Setting	Enabled	ON
	Disabled	OFF
Default	Enabled	ON

The device is in loop current mode by default. "Loop current mode" must be disabled before setting a fixed current for multidrop operation.

9.2.4.2 Loop current value in multidrop mode (02-04.02)

Sets mA value for loop current in HART multidrop mode.

Setting	3.6 to 22.8 mA
Default	4 mA

9.2.4.3 Damping value (02-04.03)

Sets the damping (filtering) of the PV to smooth out response to sudden changes in measurement.

An increase of damping increases response time of device, and affects digital value and loop current. If output values are noisy, increase parameter "Damping value". For faster response time, decrease parameter "Damping value". Find a value that meets requirements of signal stability and response time.

Setting	0 to 100 s
Default	0 s

Note**Damped PV**

The process value that is set as the primary variable (PV) for the application, is damped using values in parameters "Damping value" and "Sensor damping value".

All other process values (not set by default or selected as the main PV), are damped only by the value in parameter "Sensor damping value".

Note**Rate parameters**

The three rate parameters "Fill rate", "Empty rate", and "Damping value" work in conjunction, and are affected by parameter "Response rate" (set in the quick commissioning wizard).

The rate parameters automatically adjust when parameter "Response rate" is altered, but any changes made to the rate parameters following the completion of the wizard will supersede the response rate setting.

9.2.4.4 Lower range value (02-04.04)

Sets process value that corresponds to 4 mA loop current.

Setting	-9999999 to +9999999
Default	0 ("Units" based on PV)

9.2.4.5 Upper range value (02-04.05)

Sets process value that corresponds to 20 mA loop current.

Setting	-9999999 to +9999999
Default	100 ("Units" based on PV)

Note

"Upper range value" (URV) versus "Upper scaling point"

- When parameter "Upper range value" is set within the "Quick commissioning wizard", it automatically sets the "Upper scaling point" to the same value.
- Setting a value for either parameter *outside* of the wizard, will not automatically adjust the other value.

Note

Changing custom units

If a change is made to custom units, be sure to rescale the output, as rescaling for custom units is not handled automatically by the device.

- Use parameters "Upper range value" and "Upper scaling point" to rescale output.

9.2.4.6 Lower saturation limit (02-04.06)

Sets lower limit for saturation range (4 mA to parameter "Lower saturation limit"), past which the loop current cannot decrease.

Setting	3.55 to 4 mA
Default	3.8 mA

9.2.4.7 Upper saturation limit (02-04.07)

Sets upper limit for saturation range (20 mA to parameter "Upper saturation limit"), past which the loop current cannot increase.

Setting	20 to 22.8 mA
Default	20.5 mA

9.2.4.8 Lower fault current (02-04.08)

Sets Lower fault current in Non-safety mode.

Setting	3.55 to 3.8 mA
Default	3.55 mA

9.2.4.9 Upper fault current (02-04.09)

Sets Upper fault current in Non-safety mode.

Setting	20.5 to 22.8 mA
Default	22.8 mA

9.2.4.10 Fault current (02-04.10)

Defines behavior when Fail-safe is initiated.

Setting	Upper fault current	UPPER
	Lower fault current	LOWER
Default	Lower fault current	LOWER

See Fault codes and corrective actions (Page 165) for a list of faults that initiate **Fail-safe**, causing "Fault current" setting to display.

9.2.4.11 Fail-safe loss of echo (02-04.11)

Defines fail-safe behavior when fail-safe loss of echo occurs and fail-safe LOE timer expires.

Setting	Hold	HOLD	Last valid reading
	Fault current	FAULT	Value set in parameter "Fault current"
Default	Hold	HOLD	

9.2.4.12 Fail-safe LOE timer (02-04.12)

Sets amount of time loss of echo will persist before device enters fail-safe mode.

Setting	0 to 720 s
Default	100 s



9.2.5 Volume (M 02-05)**Note****Menu visibility**

This menu will not appear on device unless it is configured.

9.2.5.1 Vessel shape (02-05.01)

Sets vessel shape, and allows device to calculate volume instead of level.

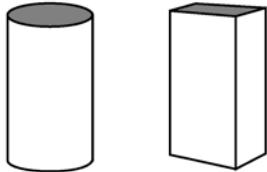
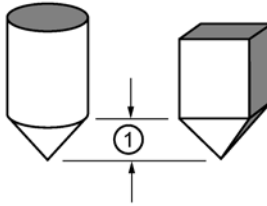
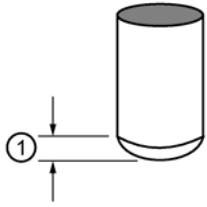
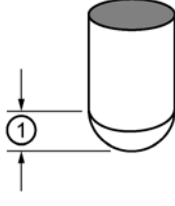
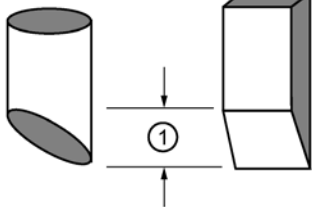
9.2 Setup (M 02)

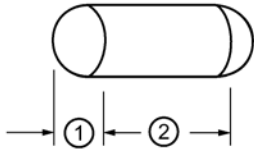
	Display name/description	Vessel shape	Other parameter settings required
Setting	LINR Linear vessel		Upper scaling point
	CONIC Conical bottom vessel		Upper scaling point, Vessel dimension A
	PARAB Parabolic bottom vessel		Upper scaling point, Vessel dimension A
	HALF Half sphere bottom vessel		Upper scaling point, Vessel dimension A
	FLAT Flat sloped bottom vessel		Upper scaling point, Vessel dimension A
	CYLIN Cylinder vessel		Upper scaling point
	PARAE Parabolic ends vessel		Upper scaling point, Vessel dimension A, Vessel dimension L

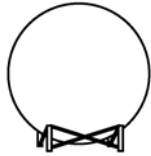
	SPHER Sphere vessel		Upper scaling point
Default	LINR	Linear vessel	

① Dimension A ② Dimension L

9.2.5.2 Vessel dimension A (02-05.02)

Sets height of vessel bottom when bottom is conical, parabolic, half spherical, or flat sloped. If horizontal parabolic ends vessel, sets depth of end.

Setting	0 to 99.999 m
Default	0

See Vessel shape (02-05.01) (Page 121) for illustration.

9.2.5.3 Vessel dimension L (02-05.03)

Sets length of cylindrical section of horizontal parabolic ends vessel.

Setting	0 to 99.999 m
Default	0

See Vessel shape (02-05.01) (Page 121) for illustration.

9.2.5.4 Volume units (02-05.04)

Sets volume measurement units.

Setting	Cubic meters	m3
	Liters	l
	US gallons	Ga
	Imperial gallons	IGa
Default	Cubic meters	m3

9.2.5.5 Upper scaling point (02-05.05)

Sets maximum scaled measurement value.

Setting	0 to 9999999
Default	100 liters

Note

"Upper range value" (URV) versus "Upper scaling point"

- When parameter "Upper range value" is set within the "Quick commissioning wizard", it automatically sets the "Upper scaling point" to the same value.
- Setting a value for either parameter *outside* of the wizard, will not automatically adjust the other value.

9.2.6 Volume flow (M 02-06)

Note

Menu visibility

This menu will not appear on device unless it is configured.

9.2.6.1 Primary measuring device (02-06.01)

Sets the type of primary measuring device (PMD) used.

Setting	Exponential devices	EXPON
	Rectangular flume BS-3680	RECFL
	Round nose horizontal crest weir BS-3680	RNHWR
	Trapezoidal flume BS-3680	TRPFL
	U-flume BS-3680	UFLM
	Finite crest weir BS-3680	FINWR
	Thin plate rectangular weir BS-3680	TPRWR
	Thin plate V-notch weir BS-3680	TPVWR
	Rectangular weir contracted	RWRC
	Round pipe	RPIPE
	Palmer-Bowlus flume	PBFLM
	H-flume	HFLM
	Default	Exponential devices

9.2.6.2 Method of flow calculation (02-06.02)

Sets method of flow calculation.

Setting	Absolute	ABS
	Ratiometric	RATIO
Default	Absolute	ABS

Set this parameter to "Ratiometric" only if the primary measuring device (PMD) supports ratiometric calculations. (Note that Palmer Bowlus Flume and H-Flume support ratiometric calculations only.) For more details on absolute and ratiometric calculations, see Method of flow calculation (Page 199).

9.2.6.3 Volume flow units (02-06.03)

Sets measurement units used when parameter "PV selection" set to "Volume flow".

Setting	Liters per second	l/S
	Liters per minute	l/m
	Cubic feet per second	Ft3/S
	Cubic feet per day	Ft3/d
	US gallons per minute	Ga/m
	US gallons per day	Ga/d
	Imperial gallons per minute	lGa/m
	Imperial gallons per day	lGa/d
	Cubic meters per hour	m3/h
	Cubic meters per day	m3/d
	US million gallons per day	MGl/d
Default	Liters per second	l/S

9.2.6.4 Upper scaling point (02-06.04)

Sets maximum scaled measurement value.

Setting	0 to 9999999
Default	100 liters per second

Note**"Upper range value" (URV) versus "Upper scaling point"**

- When parameter "Upper range value" is set within the "Quick commissioning wizard", it automatically sets the "Upper scaling point" to the same value.
- Setting a value for either parameter *outside* of the wizard, will not automatically adjust the other value.

9.2.6.5 PMD dimensions (M 02-06-05)

Sets dimensions of primary measuring device (PMD), to calculate volume.

The following table is a reference to the parameters that must be set for each PMD.

Supported PMD	Dimensions required
Exponential devices	
	Flow exponent
	K-factor
Rectangular flume BS-3680	
	OCM dimension 1: Approach width
	OCM dimension 2: Throat width
	OCM dimension 3: Hump height
	OCM dimension 4: Throat length
Round nose horizontal crest weir BS-3680	
	OCM dimension 1: Crest width
	OCM dimension 2: Crest height
	OCM dimension 3: Crest length
Trapezoidal flume BS-3680	
	OCM dimension 1: Approach width
	OCM dimension 2: Throat width
	OCM dimension 3: Hump height
	OCM dimension 4: Throat length
	Slope
U-flume BS-3680	
	OCM dimension 1: Approach diameter
	OCM dimension 2: Throat diameter
	OCM dimension 3: Hump height
	OCM dimension 4: Throat length
Finite crest weir BS-3680	
	OCM dimension 1: Crest width
	OCM dimension 2: Crest height
	OCM dimension 3: Crest length
Thin plate rectangular weir BS-3680	
	OCM dimension 1: Approach width
	OCM dimension 2: Crest width
	OCM dimension 3: Crest height
Thin plate V-notch weir BS-3680	
	V-Notch angle
Rectangular weir contracted	
	OCM dimension 1: Crest width

Supported PMD	Dimensions required
Round pipe	
	OCM dimension 1: Pipe diameter
	Slope
	Roughness coefficient
Palmer-Bowlus flume	
	OCM dimension 1: Maximum flume width
H-flume	
	OCM dimension 1: Flume height
Custom	
	Volume (up to 32)
	Flow (up to 32)

Flow exponent (02-06-05.01)

Sets exponent for flow calculation formula.

Setting	-999 to 9999
Default	1.55

Use if parameter "Primary measuring device" is set to "Exponential devices". The flow exponent is used to create an exponential curve with end points set by "Upper scaling point" and Zero level (head), and with the curve based on the specified exponent.

Maximum flow

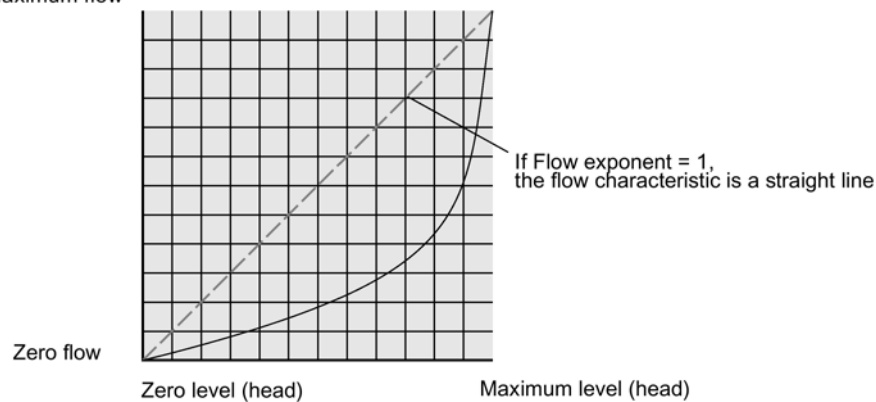

The exponential equation is

$$Q = KH^{\text{Flow exponent}}$$

Where:

Q = flow

K = constant factor

H = level (head)

Use the exponent specified by the PMD manufacturer, if available, or relevant Open Channel Monitoring reference material.

K-factor (02-06-05.02)

Sets constant used in volume flow calculation formula, for absolute calculation of exponential device only.

Setting	-999 to 99999
Default	1.0

Use if parameter "Primary measuring device" is set to "Exponential devices". The constant factor (K-factor) is used to create an exponential curve with end points set by "Upper scaling point" and Zero level (head), and with the curve based on the specified exponent.

Note

Accurate flow calculation

In a volume flow application using **exponential device**, and **absolute** method of flow calculation, the following must be consistent for flow calculation to be valid:

- Engineering units for level (parameter "Units")
- Engineering units for volume flow (parameter "Volume flow units")
- Constant factor (parameter "K-factor").

V-notch angle (02-06-05.03)

Sets V-notch angle used in volume flow calculation formula.

Setting	25° to 95°
Default	25°

Use when parameter "PMD dimensions" is set to "Thin plate V-Notch weir BS-3680".

Slope (02-06-05.04)

Sets flow slope used in volume flow calculation formula.

Setting	0 to 1
Default	0

Use when parameter "PMD dimensions" is set to "Trapezoidal flume BS-3680" or "Round pipe".

Roughness coefficient (02-06-05.05)

Sets flow roughness coefficient used in volume flow calculation formula.

Setting	-999 to 9999
Default	0

Use when parameter "PMD dimensions" is set to "Round pipe".

OCM dimension 1 (02-06-05.06)

Sets OCM dimension for each directly supported primary measuring device (PMD).

See table under parameter "PMD dimensions" to relate "OCM Dimension 1 - 4" to a specific dimension for each directly supported primary measuring device. For PMDs that are not directly supported, use a universal flow calculation. See Custom calculation support (Page 99).

For more information, see Open Channel Monitoring (OCM) (Page 80).

OCM dimension 2 (02-06-05.07)**OCM dimension 3 (02-06-05.08)****OCM dimension 4 (02-06-05.09)****9.2.7 Custom (M 02-07)****Note****Menu visibility**

This menu will not appear on device unless it is configured.

9.2.7.1 Upper scaling point (02-07.01)

Sets maximum scaled measurement value.

Setting	0 to 9999999
Default	100 <Custom units>

Note**"Upper range value" (URV) versus "Upper scaling point"**

- When parameter "Upper range value" is set within the "Quick commissioning wizard", it automatically sets the "Upper scaling point" to the same value.
- Setting a value for either parameter *outside* of the wizard, will not automatically adjust the other value.

9.2.7.2 Customized characteristic curve (M 02-07.02)

Used to enter Level and Output breakpoints for universal Primary measuring device (PMD).

If the shape of vessel (volume) or PMD (volume flow) is more complex than any of the preconfigured shapes, you can define the shape as a series of segments. A value is assigned to each input (level) breakpoint and a corresponding value is assigned to each output (volume or volume flow) breakpoint.

- Level values are defined in Units (02-02.01) (Page 112).
- Volume values are defined in Volume units (02-05.04) (Page 123).
- Volume flow values are defined in Volume flow units (02-06.03) (Page 125).

For more information, see Volume calculation (Page 196) , or Volume flow calculation (Page 198).

Custom units can only be defined via remote operation (see Custom units (Page 150)).

X-value 1...X-value 32 (02-07-02.01)

Sets level breakpoints for which output is known.

Setting	0 to 99999
Default	0

Y-value 1...Y-value 32 (02-07-02.02)

Sets output corresponding to each input breakpoint entered.

Setting	0 to 9999999
Default	0

9.2.8 Local display (M 02-08)

9.2.8.1 Start view (02-08.01)

Sets process value shown first on display after power on.

Setting	Level	LEVEL
	Space	SPACE
	Distance	DIST
	Volume	VOL
	Volume flow	VFLOW
	Custom	CUSTM
	Loop current	LOOPC
	Primary variable	PV
	% of range	%
	Sensor temperature	STEMP
Default	Distance	DIST

Note**Start view set automatically by wizard**

The process value to display on device after power on is set automatically by the "Quick commissioning wizard".

- When parameter "Operation" is set in the wizard, the value is written to parameter "Start view".
- If a change is made to parameter "Start view" or parameter "PV selection" after running the wizard, the last one set will apply.
- Options "Volume", "Volume flow", and "Custom" are not visible in **measurement view** until configured. If one of these unconfigured options is selected in parameter "Start view", **measurement view** will show the next visible process value.

9.2.8.2 Service view (02-08.02)

Sets operation of local device display to show menu numbers in **navigation view**.

Setting	Enabled	ON
	Disabled	OFF
Default	Disabled	OFF

Note**Show menu numbers on local display**

To view menu numbers on the device, parameter "Service view" must be enabled. (Go to menu "**Setup > Local display**".)

- The item number of the current selection appears in the **info field**.
- The menu number in which the current selection resides, appears on the **title line** (thus no menu numbers appear for top-level menu items, such as "QUICK START", "SETUP", etc.).

Refer to full device menu in **HMI menu structure**.

9.2.8.3 Display test wizard (02-08.03)

Used to test device display.

Setting	Start	START
	Cancel	CANCL
Default	Start	START

The "Display test wizard" commands the field device to perform a test of all segments on the local display.

This test is accessible only via local operation, and a bar graph shows progress of test. After test is complete the message "COMPL" appears.

9.3 Maintenance and diagnostics (M 03)

The following parameters relate to device maintenance and diagnostics.

9.3.1 Signal (M 03-01)

9.3.1.1 Signal quality (M 03-01-01)

Short shot confidence (03-01-01.01)

Displays short shot echo quality: higher values represent better echo quality.

Confidence (03-01-01.02)

Displays echo quality: higher values represent better echo quality.

Short shot echo signal strength (03-01-01.03)

Displays strength of short shot echo, in dB.

Echo signal strength (03-01-01.04)

Displays strength of selected echo, in dB.

Noise average (03-01-01.05)

Displays the average ambient noise, in dB.

The noise level is a combination of transient acoustic noise and electrical noise (induced into the receiving circuitry). See Noise problems (Page 174).

Noise parameter values are automatically updated periodically.

Noise peak (03-01-01.06)

Displays the peak ambient noise, in dB.

Noise parameter values are automatically updated periodically.

9.3.1.2 Echo configuration (M 03-01-02)

Near range (03-01-02.01)

Sets minimum distance from sensor reference point, beyond which an echo should be considered valid.

This is sometimes referred to as blanking or a dead zone.

Setting	<ul style="list-style-type: none"> • 0 to 6 m (6 m device) • 0 to 12 m (12 m device)
Default	0.2 m

Far range (03-01-02.02)

Sets maximum distance from sensor reference point, within which an echo should be considered valid.

Use this feature if the measured surface can drop below the lower calibration point in normal operation.

Setting	Range for "Lower calibration point" + 2.4 m <ul style="list-style-type: none"> • 0.0 to 8.4 m (6 m device) • 0.0 to 14.4 m (12 m device)
Default	Default value for "Lower calibration point" + 1.0 m <ul style="list-style-type: none"> • 7.0 m (6 m device) • 13.0 m (12 m device)

9.3.1.3 Echo select (M 03-01-03)

Algorithm (03-01-03.01)

Sets algorithm (applied to the echo profile) to extract the true echo.

Setting	Area largest first echo	ALF
	Largest echo	L
	Largest echo area	AL
	Best echo of the first and largest echo	BLF
	True first echo	TF
Default	Best echo of the first and largest echo	BLF

Short shot echo threshold (03-01-03.02)

Sets minimum short shot echo confidence. Only echoes above this threshold are evaluated.

Setting	-20 to 70 dB
Default	10 dB

Echo threshold (03-01-03.03)

Sets minimum echo confidence. Only echoes above this threshold are considered as true echoes.

Setting	-20 to 70 dB
Default	5 dB

Position detect (03-01-03.04)

Sets algorithm used to calculate the position of the echo.

Defines where on the echo the distance measurement is determined.

Setting	Rising	RISE	Rising edge of echo (calculated using echo peak to echo floor average)
	Center	CNTR	Center of the echo
	Rising 2	RISE2	Rising edge of echo (calculated using fixed amount of 10 dB down from echo peak)
Default	Rising 2	RISE2	

Echo marker (03-01-03.05)

Sets measurement point inside window set by parameter "Echo lock window".

Setting	5% to 95%
Default	50 (%)

Applicable only when using "Rising" algorithm, set in parameter "Position detect".

9.3.1.4 Filtering (M 03-01-04)

Narrow echo filter (03-01-04.01)

Clips echoes at a specified width.

Setting	0 to 70 intervals ¹⁾ (greater=wider)
Default	0

¹⁾ One interval = span of 64 microseconds (μ s)

Use this for acoustic beam interference (e.g. ladder rungs). Enter the width of false echoes (in groups of 64 microseconds), to be removed from the echo profile. For example, select value of 3 to remove 192 microseconds (3 x 64 microseconds) of false echoes from the profile. When a value is entered, the nearest acceptable interval value in microseconds is set.

Narrow echo filter is not recommended for liquids.

Reform echo (03-01-04.02)

Used to smooth jagged peaks in the echo profile. Reforms fragmented echoes into one echo.

Setting	0 to 50 intervals ¹⁾ (greater = wider)
Default	0

¹⁾ One interval = span of 64 microseconds (μ s)

Use this feature when monitoring solids if the reported level fluctuates slightly though the monitored surface is still. Enter the amount of smoothing required to the echo profile. When a value is entered, the nearest acceptable interval value, in microseconds, is set.

Gain control (03-01-04.03)

Used to adjust signal based on echo strength.

Setting	Auto	AUTO
	Enabled	ON
	Disabled	OFF
Default	Auto	AUTO

Note

Gain control set to "Auto"

Setting parameter "Gain control" to "Auto" requires that both parameters "Number of short shots" and "Number of long shots" be set to a value of one (1) or greater.

Setting either parameter "Number of short shots" or "Number of long shots" to a value of zero (0) without taking parameter "Gain control" out of "Auto", may result in loss of echo or inaccurate measurement.

Gain lower threshold (03-01-04.04)

Sets lower threshold to enable parameter "Gain control".

Setting	0 to 99 dB
Default	42 dB

Gain upper threshold (03-01-04.05)

Sets upper threshold to disable parameter "Gain control".

Setting	0 to 99 dB
Default	45 dB

Sensor damping value (03-01-04.06)

Sets the damping (filtering) of raw sensor value to smooth out response to sudden changes in measurement.

Setting	0 to 1500 s
Default	10 s

Note

Damped PV

The process value that is set as the primary variable (PV) for the application, is damped using values in parameters "Damping value" and "Sensor damping value".

All other process values (not set by default or selected as the main PV), are damped only by the value in parameter "Sensor damping value".

Note

Damping via HART network

"Sensor damping value" cannot be applied via HART commands. Instead, use Damping value (02-04.03) (Page 119).

9.3.1.5 Sampling (M 03-01-05)

Echo lock (03-01-05.01)

Sets measurement verification process. When echo lock set to "Total lock", parameter "Echo lock window" is preset to 0 for automatic width and cannot be changed.

Setting	Disabled	OFF
	Maximum verification	MXVER
	Material agitator	M AG
	Total lock	TLOCK
Default	Material agitator	M AG

Use "Material agitator" option to prevent false echoes from agitator blades.

"Maximum verification" option can be used if experiencing frequent loss of echo (LOE). However, it is recommended that you contact your Siemens representative before activating.

Echo lock window (03-01-05.02)

Sets distance window (centered on echo) used to derive reading. When new measurement is in window, window is recentered and reading is calculated.

Range	0 to 65535 m
Default	0

Number of short shots (03-01-05.03)

Sets number of short shots to be fired (and results averaged) per transmit pulse.

Range	0 to 25
Default	1

A higher number of shots may result in a reduction in variation of the reported measurement value, but can increase the update time between measurements.

Note

Gain control set to "Auto"

Setting parameter "Gain control" to "Auto" requires that both parameters "Number of short shots" and "Number of long shots" be set to a value of one (1) or greater.

Setting either parameter "Number of short shots" or "Number of long shots" to a value of zero (0) without taking parameter "Gain control" out of "Auto", may result in loss of echo or inaccurate measurement.

Number of long shots (03-01-05.04)

Sets number of long shots to be fired (and results averaged) per transmit pulse.

Range	0 to 25
Default	1

A higher number of shots may result in a reduction in variation of the reported measurement value, but can increase the update time between measurements.

Note

Gain control set to "Auto"

Setting parameter "Gain control" to "Auto" requires that both parameters "Number of short shots" and "Number of long shots" be set to a value of one (1) or greater.

Setting either parameter "Number of short shots" or "Number of long shots" to a value of zero (0) without taking parameter "Gain control" out of "Auto", may result in loss of echo or inaccurate measurement.

Short shot duration (03-01-05.05)

Sets duration of short shot transmit pulse.

Range	150 to 2000 μ s
Default	150 μ s

Long shot duration (03-01-05.06)

Sets duration of long shot transmit pulse.

Range	150 to 2000 μ s
Default	1000 μ s

9.3.1.6 TVT configuration (M 03-01-06)

Hover level (03-01-06.01)

Sets offset of TVT above noise floor of echo profile. Value in percent with respect to noise floor and peak value of largest echo.

Setting	0 to 100%
Default	40%

Auto false echo suppression (03-01-06.02)

Used to screen out false echoes in a vessel with known obstructions.

A learned TVT (time varying threshold) replaces the default TVT over a specified range.

Setting	Enabled	ON
	Disabled	OFF
Default	Disabled	OFF

To screen out false echoes using auto false echo suppression (AFES):

1. Determine range and enter this value in parameter "Auto false echo suppression range".
2. Run "Auto false echo suppression wizard" to "learn" the TVT.

Once the wizard completes successfully, parameter "Auto false echo suppression" is set to "Enabled" and the learned TVT will be used.

Note

TVT "Learn"

Although the parameters "Auto false echo suppression" and "Auto false echo suppression range" may be adjusted on their own, the "Auto false echo suppression wizard" must be used to "learn" the TVT.

Note

AFES automatically disabled

The device will automatically reset parameter "Auto false echo suppression" to "Disabled" under the following conditions:

- Parameter "Auto false echo suppression" is manually enabled, and an initial device TVT learn is *never* requested (via AFES wizard)
- Parameter "Auto false echo suppression" is enabled (either manually or automatically based on previous TVT learn using AFES wizard), and a new TVT learn request fails (for example, due to a power failure during the learn process).

To avoid situations where AFES is disabled by the device, use "Auto false echo suppression wizard" initially. The wizard will store a learned TVT and enable AFES.

If AFES is later disabled then re-enabled, the stored TVT will be used.

Note

For best results with AFES

- Set up auto false echo suppression during commissioning if possible, by running "Auto false echo suppression wizard".
- Ensure material level is below all known obstructions at the moment when "Auto false echo suppression wizard" learns the TVT. Ideally the vessel should be empty or almost empty.
- Use auto false echo suppression only if target is greater than one meter from transducer face (sensor reference point)
- Note the distance to material level when learning the echo profile, and set value in parameter "Auto false echo suppression range" to a shorter distance to avoid the material echo being screened out.
- If the vessel contains an agitator, it should be running.

Auto false echo suppression range (03-01-06.03)

Sets end point of the learned TVT distance.

Setting	<ul style="list-style-type: none"> • 0 to 6 m (6 m device) • 0 to 12 m (12 m device)
Default	1 m

To calculate value

1. Determine the auto false echo suppression range by measuring the actual distance from the sensor reference point to the material surface using a rope or tape measure.
2. Subtract 0.5 m (20") from this distance and use the resulting value.

Custom TVT breakpoints

TVT breakpoints can be manually defined only via remote operation. See Custom TVT breakpoints (Page 232) under "Echo profile utilities" in the SIMATIC PDM menu "Device".

9.3.2 Peak values (M 03-02)

Displays peak measured values.

9.3.2.1 Minimum PV (03-02.01)

Displays minimum value of the primary variable. Value may reset when units are changed.

9.3.2.2 Maximum PV (03-02.02)

Displays maximum value of the primary variable. Value may reset when units are changed.

9.3.2.3 Minimum distance (03-02.03)

Displays minimum distance value. Value may reset when units are changed.

9.3.2.4 Maximum distance (03-02.04)

Displays maximum distance value. Value may reset when units are changed.

9.3.2.5 Minimum sensor temperature (03-02.05)

Displays minimum sensor temperature value.

9.3.2.6 Maximum sensor temperature (03-02.06)

Displays maximum sensor temperature value.

9.3.3 Loop test (M 03-03)

9.3.3.1 Loop test wizard (03-03.01)

Provides step-by-step procedure to simulate the loop current.

A loop test can be initiated via local operation (with any errors reported through diagnostic icons on the local display), or remotely, using an engineering system such as SIMATIC PDM.

Note

Simulated current output

The simulated current output value influences output to the control system.

A simulated value can be set to test the functioning of the mA connections during commissioning or maintenance of the device.

Setting	3.55
	4.0
	12.0
	20.0
	22.8
	User (Set any mA value between 3.6 and 22.8)
Default	12.0 mA

Select a preset mA value, or enter a custom value (under option "User") to run the wizard.

Press ◀ button to stop and exit the loop test.

For more information, see mA control (Page 77).

9.3.4 Resets (M 03-04)

9.3.4.1 Device restart (03-04.01)

Used to restart device without disconnecting power.

Simulation will be terminated. Stored configurations are not reset.

Setting	Cancel	CANCL
	Ok	OK
Default	Cancel	CANCL

9.3.4.2 Reset (03-04.02)

Used to provide various device reset options.

Setting	Factory reset	FACT
	Restore ordered configuration	CUST
Default	Factory reset	FACT

Note

Factory reset requires reprogramming

Following a reset to factory defaults, the device is in a "Not configured" state, and shows the fault "Configuration error" (code SC). The fault code remains until the device is reprogrammed.

Choosing option "Factory reset" will reset all parameters to factory defaults, with the following exceptions:

- "Device address" remains unchanged
- "User PIN" (write protection) value is not reset
- "Peak values" and "Operating time" are not reset
- "Auto false echo suppression" is reset to default (Disabled), but learned TVT is not lost
- "Custom TVT shaper mode" is reset to default (Disabled), but "Custom TVT breakpoints" are not lost

To perform a "Factory reset" via SIMATIC PDM, go to menu "**Device > Reset > Factory reset**".

Note

Restore ordered configuration requires 22.5 mA

Device output reads 22.5 mA while "Restore ordered configuration" is running. When restore is complete, device output returns to normal behavior.

- Restore takes approximately 20 seconds to complete.
- Following a restore to ordered configuration, the device is in a "Configured" state, and mA output is based on current measurement of restored PV.

Choosing option "Restore ordered configuration" restores device to customer-ordered default settings. The parameters not configured via the order are reset to the factory default settings.

In SIMATIC PDM, go to menu "**Device > Reset > Restore ordered configuration**".

A third option to "Restore to factory DAC calibration" is available via SIMATIC PDM. This option restores the DAC trim (digital-to-analog converter trim) to the factory setting. [The DAC trim is used to calibrate the 4 mA and 20 mA end points of the analog output with an external reference (e.g. current measurement device).]

Go to menu "**Device > Reset > Restore to factory DAC calibration**".

9.3.4.3 Reset peak values (03-04.03)

Resets all recorded Peak values.

Setting	No	NO
	Primary variable	PV
	Distance	DIST
	Sensor temperature	STEMP
	Peak values (Resets recorded minimum and maximum values for PV, Distance, and Sensor temperature.)	PKVAL
Default	No	NO

9.4 Communication (M 04)

The following parameters relate to device Communication.

9.4.1 Polling address (04.01)

Sets poll ID on a HART network.

For point-to-point configurations, the standard address is zero (0). For multidrop configurations, use a non-zero HART address.

Setting	0 to 63
Default	0

9.4.2 Identify the device (04.02)

Used to arm device locally to produce a visual alert (blinking display) so device can be identified.

Setting	Enabled	ON
	Disabled	OFF
Default	Disabled	OFF

Note

Optional display required

When HART command 72 is issued to the device address, a display test is run, causing the attached optional display to blink.

9.5 Security (M 05)

The following parameters relate to device Security.

9.5.1 Change user PIN (05.01)

Used to change PIN code that enables user access level.

Setting	0 to 65535
Default	0

9.5.2 Recovery ID (05.02)

Displays recovery ID that must be provided to Technical Support to obtain the PIN-Unlock-Key (PUK) required to recover the PIN(s).

Record the number shown in parameter "Recovery ID", and the serial number of the device. (Serial number can be found on device nameplate, or via remote operation if data was previously uploaded from device to EDD and saved in offline table, e.g. PDM **Structure view**.)

When you provide this information to Siemens Technical Support, a PUK (PIN Unlock Key) will be supplied to you. Enter this PUK in parameter "PIN recovery" to reset the user PIN to factory default value.

Note

Parameter visibility

Parameter "Recovery ID" will only show on the local display if parameter "User PIN" is enabled.

9.5.3 PIN recovery (05.03)

Used to enter PIN unlock key (PUK) which resets PIN(s) to factory default value. The PUK is available from Technical Support.

For more information, see Recovery ID (05.02) (Page 145).

Note

Parameter visibility

Parameter "PIN recovery" will only show on the local display if parameter "User PIN" is enabled.

9.5.4 User PIN (05.04)

Used to enable/disable user PIN. When user PIN is enabled, changes to parameter settings require a PIN to be entered.

Note

Factory PIN

Device is shipped unlocked. If device is locked unintentionally (user PIN enabled), enter PIN 2457 to unlock device (disabled user PIN).

Setting	Enabled	ON
	Disabled	OFF
Default	Disabled	OFF

In **Parameter view**, the local display shows the action that can be performed:

- If display shows "ENABL", this means that security is currently disabled
- If display shows "DISAB", this means that security is currently enabled.

Note

Effectivity of change to user PIN setting

When the setting for parameter "User PIN" is changed, it will not take effect immediately. Once setting is changed, a power cycle of the device or ten (10) minutes must pass before the change will take effect. (This delay applies only when a change is made to this parameter on the local device, not via remote operation.)

9.5.5 Button lock (05.05)

Sets access to device buttons. When lock enabled, device operation is only possible via engineering system.

To disable lock locally press right button for 5 seconds, or use engineering system to disable remotely.

Setting	Enabled	ON	Button lock enabled
	Disabled	OFF	Button lock disabled
Default	Disabled	OFF	

Parameter assignment - Remote

This chapter includes all parameters accessible via a remote engineering system (such as SIMATIC PDM, or AMS Device Manager).

Parameters are organized into similar functions groups and menu structure as those accessible via local operation, although structure varies slightly. Refer to the **Structure view** in SIMATIC PDM, or the **Configure/Setup** menu in AMS Device Manager. (If a parameter is not available in PDM **Structure view**, refer to the PDM menus: Parameters and methods via PDM menus (Page 212).)

For more details, see:

- SIMATIC PDM (Page 209)
- AMS device manager (Page 239)
- Field Communicator (FC) 375/475 (Page 240)
- FDT (Field Device Tool) (Page 241)

10.1 Identification

The following Identification parameters are accessible only via a remote engineering system (such as SIMATIC PDM).

10.1.1 Tag

Defines a unique tag name for device or measurement point. Limited to 8 characters.

10.1.2 Long tag

Defines a unique tag name for device or measurement point. Limited to 32 characters.

10.1.3 Descriptor

Defines a unique description for the measuring point. Limited to 16 characters.

10.1.4 Message

Sets unique message for device. Limited to 32 characters.

10.1 Identification

10.1.5 Installation date

Sets the installation date of the device.

10.1.6 Device

10.1.6.1 Manufacturer

Displays manufacturer of device.

10.1.6.2 Product name

Displays product name.

10.1.6.3 Protocol

Displays communication protocol supported by device.

10.1.6.4 Article number

Displays the article number (MLFB) of the device.

10.1.6.5 Order option 1

Displays number for specific customer order option.

10.1.6.6 Order option 2

Displays number for specific customer order option.

10.1.6.7 Serial number

Displays unique serial number of device, set by factory.

10.1.6.8 HW version

Displays version number corresponding to electronics hardware of device.

10.1.6.9 FW version

Displays version number corresponding to software or firmware embedded in device.

10.1.6.10 EDD version

Displays version number corresponding to Electronics Device Description (EDD) installed with device.

10.1.6.11 Final assembly number

Sets a number to identify the materials and electronics of the device. Can be modified if the device is upgraded in the field.

It is normally changed when electronics or other device components are upgraded in the field. In some plants this number references a drawing (e.g. a PI&D drawing).

10.2 Setup

Setup parameters under the following menus are accessible via both an engineering system and the local display (HMI). For more details, see respective link to Parameter assignment - Local chapter.

- Select output (M 02-01) (Page 110)
- Sensor (M 02-02) (Page 112)
- Calibration (M 02-03) (Page 114)
- Current output (M 02-04) (Page 118)
- Volume (M 02-05) (Page 121)
- Volume flow (M 02-06) (Page 124)
- Local display (M 02-08) (Page 130)
- Custom (M 02-07) (Page 129)

Additional Setup parameters as detailed below, are accessible only via an engineering system. For example, these parameters can be found in the Structure view of SIMATIC PDM, or in the Configure/Setup menu of AMS Device Manager.

- Custom
 - Custom units

10.2.1 Custom units

Sets unit text to display, in a custom application. Limited to 16 characters.

The text entered is simply for display purposes. No unit conversion occurs.

Note

Changing custom units

If a change is made to custom units, be sure to rescale the output, as rescaling for custom units is not handled automatically by the device.

- Use parameters "Upper range value" and "Upper scaling point" to rescale output.
-

10.3 Maintenance and diagnostics

Maintenance and diagnostics parameters under the following menus, are accessible via both an engineering system and the local display (HMI). For more details, see respective link to Parameter assignment - Local chapter.

- Signal (M 03-01) (Page 132)
 - Signal quality (M 03-01-01) (Page 132)
 - Echo configuration (M 03-01-02) (Page 133)
 - Echo select (M 03-01-03) (Page 133)
 - Filtering (M 03-01-04) (Page 135)
 - Sampling (M 03-01-05) (Page 137)
 - TVT configuration (M 03-01-06) (Page 138))
- Peak values (M 03-02) (Page 140))

Additional Maintenance and diagnostics parameters as detailed below, are accessible only via an engineering system. For example, these parameters can be found in the Structure view of SIMATIC PDM, or in the Configure/Setup menu of AMS Device Manager.

- Audit trail

10.3.1 Audit trail

10.3.1.1 Configuration change counter

Displays number of times device configuration or calibration changed, locally or via engineering system.

10.4 Communication

The following Communication parameters are accessible only via a remote engineering system (such as SIMATIC PDM).

For example, these parameters can be found in the **Structure view** of SIMATIC PDM, or in the Configure/Setup menu of AMS Device Manager.

- Manufacturer's ID
- HART expanded device type
- Device ID
- HART device revision
- HART software revision
- HART hardware revision
- HART EDD revision
- Universal command revision
- Device profile code
- Polling address

10.4.1 Manufacturer's ID

Displays numerical code that refers to manufacturer of device.

10.4.2 HART expanded device type

Displays numerical code that refers to manufacturer's ID plus device type.

10.4.3 Device ID

Displays unique ID for device, set by manufacturer.

10.4.4 HART device revision

Displays device revision associated with a specific EDD.

10.4.5 HART software revision

Displays HART software revision used with device.

10.5 Security

10.4.6 HART hardware revision

Displays HART hardware revision used with device.

10.4.7 HART EDD revision

Displays HART EDD revision used with device.

10.4.8 Universal command revision

Displays revision of Universal Device Description associated with device.

10.4.9 Device profile code

Displays the type of device.

10.4.10 Polling address

Sets poll ID on a HART network.

For point-to-point configurations, the standard address is zero (0). For multidrop configurations, use a non-zero HART address.

10.5 Security

The following Security parameters are accessible via both an engineering system and the local display (HMI).

- User PIN (05.04) (Page 146)
- Button lock (05.05) (Page 146)

Parameters available via the menu **Security** on the local display, such as "Change user PIN wizard", "Recovery ID" and "PIN recovery", can be found in PDM under menu "**Device > Security**".

10.6 Characteristics

Characteristics parameters as detailed below are accessible only via an engineering system.

- Certificates and approvals
 - Intrinsic safety
 - Flameproof/Explosion proof
 - Increased safety
 - Protection by enclosure/Dust ignition proof
 - Non-sparking/Non-incendive
 - Protection by encapsulation
- Sensor limits
 - Lower limit
 - Upper limit
 - Minimum measuring span

10.6.1 Certificates and approvals

10.6.1.1 Intrinsic safety

Displays whether device has type of protection "Intrinsic safety". Examples: Ex ia, Ex ib, Ex ic

10.6.1.2 Flameproof/Explosion proof

Displays whether device has type of protection "Flame proof/Explosion proof". Example: Ex d

10.6.1.3 Increased safety

Displays whether device has type of protection "Increased safety". Examples: Ex eb, Ex ec

10.6.1.4 Protection by enclosure/Dust ignition proof

Displays whether device has "Protection by enclosure/Dust ignition proof". Examples: Ex ta, Ex tb, Ex tc

10.6.1.5 Non-sparking/Non-incendive

Displays whether device has type of protection "Non-sparking/Non-incendive". Examples: Ex nA

10.6 Characteristics

10.6.1.6 Protection by encapsulation

Displays whether device has "Protection by encapsulation". Examples: Ex ma, Ex mb, Ex mc

10.6.2 Sensor limits

10.6.2.1 Lower limit

Displays minimum usable value for parameter "Lower range value".

10.6.2.2 Upper limit

Displays maximum usable value for parameter "Upper range value".

10.6.2.3 Minimum measuring span

Defines the smallest allowable difference between the upper range value and the lower range value.

Service and maintenance

11.1 Basic safety notes

The device is maintenance-free. However, a periodic inspection according to pertinent directives and regulations must be carried out.

An inspection can include check of:

- Ambient conditions
- Seal integrity of the process connections, cable entries, and cover screws
- Reliability of power supply, lightning protection, and grounds

11.1.1 Steps for periodic inspection

Suggested steps for a periodic inspection:

- Clean the device
- Inspect for damage, cracks, or changes since installation
- Check the display for any diagnostic symbols or error messages

NOTICE

Penetration of moisture into the device

Device damage.

- Make sure when carrying out cleaning and maintenance work that no moisture penetrates the inside of the device.

CAUTION

Releasing button lock

Improper modification of parameters could influence process safety.

- Make sure that only authorized personnel may cancel the button locking of devices for safety-related applications.

11.2 Cleaning

Cleaning the enclosure

- Clean the outside of the enclosure with the inscriptions and the display window using a cloth moistened with water or a mild detergent.
- Do not use any aggressive cleansing agents or solvents, e.g. acetone. Plastic parts or the painted surface could be damaged. The inscriptions could become unreadable.

 **WARNING**

Maintenance during continued operation in a hazardous area

There is a risk of explosion when carrying out repairs and maintenance on the device in a hazardous area.

- Isolate the device from power.
- or -
- Ensure that the atmosphere is explosion-free (hot work permit).

11.3 Maintenance and repair work

 **WARNING**

Impermissible repair of the device

- Repair must be carried out by Siemens authorized personnel only.

 **WARNING**

Humid environment

Risk of electric shock.

- Avoid working on the device when it is energized.
- If working on an energized device is necessary, ensure that the environment is dry.
- Make sure when carrying out cleaning and maintenance work that no moisture penetrates the inside of the device.

11.3.1 Replacing the display

11.3.1.1 Remove existing display

To remove display for wiring or to replace a damaged display, follow steps below:

1. Turn lid by hand in a counter-clockwise direction to remove it from device.
2. Remove display by gently turning the display a quarter turn counter-clockwise, to free it from the enclosure.
3. Pull up to disconnect display cable from connector. The display is now free to lift out of enclosure.
(Dispose of a damaged display according to local regulations.)

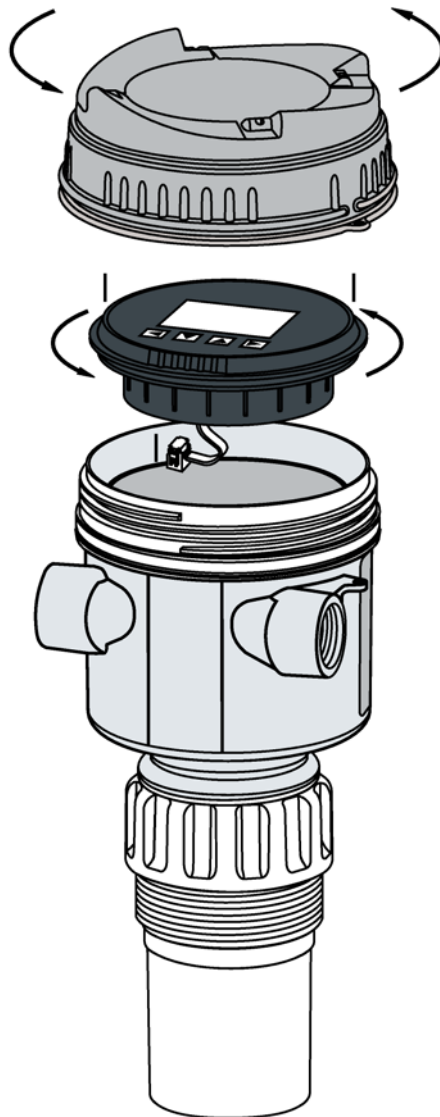

11.3.1.2 Install a new display

Note

Mounting orientation for display

The display can be mounted in 1 of 4 positions at 90 degree intervals, for easy viewing after installation.

1. Press the female end of cable from replacement display onto male four-pin connector.
2. Set replacement display into enclosure approximately one quarter turn counter-clockwise from the desired final orientation. Gently turn display one quarter turn clockwise to secure the display in the enclosure.
3. Replace device lid. Thread onto enclosure, turning clockwise. Hand tighten.

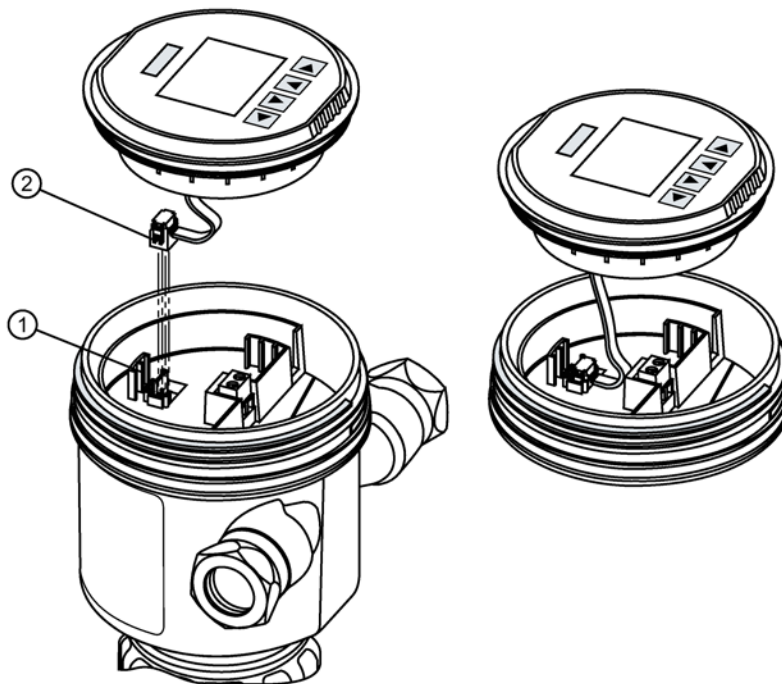

- ① Male four-pin connector
- ② Female end of display cable

11.3.2 Spare parts list

Below is a list of spare parts with article numbers for this device.

Part description	Article number
Spare lid, clear	A5E44267491
Spare lid, blind	A5E44267497
Spare o-ring for lid	A5E44267501
Spare segmented display and 4-button HMI	A5E44809382

11.4 Return procedure

Enclose the bill of lading, return document and decontamination certificate in a clear plastic pouch and attach it firmly to the outside of the packaging.

Required forms

- Delivery note
- Return goods delivery note
(<http://www.siemens.com/processinstrumentation/returngoodsnote>)
with the following information:
 - Product (item description)
 - Number of returned devices/replacement parts
 - Reason for returning the item(s)
- Decontamination declaration (<http://www.siemens.com/sc/declarationofdecontamination>)

With this declaration you warrant "that the device/replacement part has been carefully cleaned and is free of residues. The device/replacement part does not pose a hazard for humans and the environment."

If the returned device/replacement part has come into contact with poisonous, corrosive, flammable or water-contaminating substances, you must thoroughly clean and decontaminate the device/replacement part before returning it in order to ensure that all hollow areas are free from hazardous substances. Check the item after it has been cleaned.

Any devices/replacement parts returned without a decontamination declaration will be cleaned at your expense before further processing.

11.5 Disposal



Devices described in this manual should be recycled. They may not be disposed of in the municipal waste disposal services according to the Directive 2012/19/EC on waste electronic and electrical equipment (WEEE).

Devices can be returned to the supplier within the EC, or to a locally approved disposal service for eco-friendly recycling. Observe the specific regulations valid in your country.

Further information about devices containing batteries can be found at: Information about battery / product return (WEEE)

[\(https://support.industry.siemens.com/cs/document/109479891/\)](https://support.industry.siemens.com/cs/document/109479891/)

Note

Special disposal required

The device includes components that require special disposal.

- Dispose of the device properly and environmentally through a local waste disposal contractor.
-

Diagnosing and troubleshooting

12.1 Communication troubleshooting

Note**Understanding ultrasonic technologies**

- Many parameters referenced and techniques described here require a good understanding of ultrasonic technologies and Siemens echo processing software. Use this information with caution.
 - If setup becomes too confusing, perform a device reset and start again.
 - As a further resource, "Understanding Ultrasonic Level Measurement" is available on our website. Go to:
Siemens level (<http://www.siemens.com/ultrasonics>)
Select "Training center > E-Learning > epubs".
-

Generally

1. Check the following:
 - Power is available at device.
 - Optional display shows relevant data.
 - Device can be programmed using local buttons.
 - If any fault codes show on display, see Fault codes and corrective actions (Page 165) for a detailed list.
2. Verify that wiring connections are correct.

Specifically

1. If the device is set to communicate via a HART modem but no communication is returning to the master, check that the device address is set correctly for the HART network.
2. If a device parameter is set via remote communication, but the parameter remains unchanged, try setting the parameter using local buttons. If it cannot be set locally, ensure Button lock (05.05) (Page 146) is set to "Off", and that User PIN is deactivated.

If you continue to experience problems, go to:

Product page (www.siemens.com/sitransprobelu240)

Check the FAQs for this device, or contact your Siemens representative.

12.2 Device status symbols

Device status is shown using symbols on the local display. Additionally, the symbol and respective text message for each device status can be seen in remote engineering, asset management or process control systems.

Locally, in **measurement view**, alarms are shown as a symbol in the lower line of the display. If several diagnostic states are active at the same time, the symbol for the most critical state is shown.

Device status characteristics

The following table provides possible cause of device status and actions for the user or service.

The symbols used on the local display are based on NAMUR status signals, whereas symbols used in SIMATIC PDM are based on Siemens standard alarm classes.

Note

Device status priority conflict - Namur vs Siemens standard

When more than one diagnostic event is active simultaneously, a conflict in priorities may arise. In this case, the Namur symbol on the local display will differ from that shown in SIMATIC PDM.

- For example: if both diagnostic states "Maintenance demanded" and "Configuration error" are active,
 - Local display (using Namur symbols) will show "Configuration error" as higher priority.
 - SIMATIC PDM (using Siemens standard symbols) will show "Maintenance demanded" as higher priority.

Be aware of the priority for each device status, depending on the interface used.













Note

Namur device status priorities









This device uses Namur device status priorities based on HCF specification.

The sequence of symbols in the table corresponds to the priority of the device status, beginning with the most critical.

Device status symbols

Local display - NAMUR NE 107		NAMUR - HCF	SIMATIC PDM/PLC		
Symbol	Device status	Priority *	Symbol	Device status	Priority **
	Failure	1		Maintenance alarm	1
Cause: Output signal invalid due to fault in the field device or in the peripherals. Action: Maintenance is required immediately.					
	Maintenance required	4		Maintenance demanded	2
Cause: Output signal is still valid, but wear reserve is almost exhausted and/or a function will be limited soon. Action: Maintenance is strongly recommended as soon as possible.					
	Maintenance required	4		Maintenance required	3
Cause: Output signal is still valid. No functional restriction detected but end of wear reserve expected in next weeks. Action: Maintenance of device should be planned.					
	Function check	2		Manual operation	4
Cause: Output signal temporarily invalid (e.g. frozen) due to work being performed on the device. Action: Disable manual mode via HMI or engineering system.					
	Function check	2		Simulation or substitute value	5
Cause: Output signal temporarily does not represent the process because output based on a simulation value. Action: Disable simulation mode via HMI or engineering system or restart device.					
	Failure	1		Out of service	6
Cause: Output signal does not represent process value. Device mode is set to "Out of service". Action: Disable "out of service" and enable normal operation.					

12.2 Device status symbols

Local display - NAMUR NE 107		NAMUR - HCF	SIMATIC PDM/PLC		
Symbol	Device status	Priority *	Symbol	Device status	Priority **
	Failure	1	 (red)	Configuration error	7
<p>Cause: Output signal invalid due to a parameter setting, connection error or a configuration error in the HW. Action: Check hardware configuration or parameter settings of the device via HMI or engineering system.</p>					
	Out of specification	3		Process value alarm	8
<p>Cause: Deviations from permissible ambient or process conditions detected by the device (through self-monitoring, or warnings / faults in the device) indicate that the measured value is unreliable or deviations from the set value in the actuators is most likely greater than anticipated under normal operating conditions. Process or ambient conditions will damage the device or result in unreliable output. Action: Check ambient temperature or process conditions. If possible, install device at different location.</p>					
	Function check	2	 (yellow)	Configuration warning	9
<p>Cause: Device can operate, but one or more parameters are incorrectly configured. Action:</p>					
	Out of specification	3		Process value warning	10
<p>Cause: Deviations from permissible ambient or process conditions detected by the device (through self-monitoring, or warnings / faults in the device) indicate that the measured value is unreliable or deviations from the set value in the actuators is most likely greater than anticipated under normal operating conditions. Process or ambient conditions can damage the device or result in unreliable output. Action: Check ambient temperature or process conditions. If possible, install device at different location.</p>					
No symbol shown				Process value tolerance	11
<p>Cause: At least one process value has exceeded or fallen below a process tolerance limit parameter set in device. Action: Check that limit parameter settings are suitable for application.</p>					
No symbol shown			No symbol shown	Configuration changed	12
<p>Cause: The device configuration has changed due to a work process. Action: Reset configuration flag to clear diagnostic message.</p>					

Local display - NAMUR NE 107		NAMUR - HCF	SIMATIC PDM/PLC		
Symbol	Device status	Priority *	Symbol	Device status	Priority **
No symbol shown	Good - OK		No symbol shown	No assignment	13
Cause: Device status ok. No active diagnostic errors. Action: No action required.					

* Lowest priority number equals highest fault severity.

** Both the Siemens standard symbol and its corresponding Namur symbol (from device display) will be shown in SIMATIC PDM.

12.3 Device information symbols

Information symbols





In addition to device status symbols, information symbols appear on the local display.

See Display symbols (Page 41).

















12.4 Fault codes and corrective actions

















In the following table the diagnostic message IDs are listed along with possible causes and directions for corrective action.

















Certain faults exist, that when triggered initiate a **Fail-safe** state. Usually this means that the mA output displays the setting in parameter "Fault current". These faults are indicated with a single asterisk (*) in the table below. For faults that display a mA output, set by something other than parameter "Fault current", refer to numbered footnotes.









ID	Symbols	Message	Cause/action
A0*	 	Event counter 1 Number overruns above threshold Maintenance alarm	The number of overruns of the process value (set in parameters "Upper limit" and "Monitored value") has reached the threshold. Reset and acknowledge event counter. Check process conditions. Check limit monitoring and event counter settings.
A1	 	Event counter 1 Number underruns above threshold Process value alarm	The number of underruns of the process value (set in parameters "Lower limit" and "Monitored value") has reached the threshold. Reset and acknowledge event counter. Check process conditions. Check limit monitoring and event counter settings.

12.4 Fault codes and corrective actions

















ID	Symbols	Message	Cause/action
A2	 	Event counter 1 Number underruns above threshold Maintenance required	The number of underruns of the process value (set in parameters "Lower limit" and "Monitored value") has reached the threshold. Reset and acknowledge event counter. Check process conditions. Check limit monitoring and event counter settings.
A3*	 	Event counter 1 Number underruns above threshold Maintenance alarm	The number of underruns of the process value (set in parameters "Lower limit" and "Monitored value") has reached the threshold. Reset and acknowledge event counter. Check process conditions. Check limit monitoring and event counter settings.
A4	 	Event counter 2 Number overruns above threshold Process value alarm	The number of overruns of the process value (set in parameters "Upper limit" and "Monitored value") has reached the threshold. Reset and acknowledge event counter. Check process conditions. Check limit monitoring and event counter settings.
A6	 	Event counter 2 Number overruns above threshold Maintenance required	The number of overruns of the process value (set in parameters "Upper limit" and "Monitored value") has reached the threshold. Reset and acknowledge event counter. Check process conditions. Check limit monitoring and event counter settings.
A7*	 	Event counter 2 Number overruns above threshold Maintenance alarm	The number of overruns of the process value (set in parameters "Upper limit" and "Monitored value") has reached the threshold. Reset and acknowledge event counter. Check process conditions. Check limit monitoring and event counter settings.
A8	 	Event counter 2 Number underruns above threshold Process value alarm	The number of underruns of the process value (set in parameters "Lower limit" and "Monitored value") has reached the threshold. Reset and acknowledge event counter. Check process conditions. Check limit monitoring and event counter settings.
A9	 	Event counter 2 Number underruns above threshold Maintenance required	The number of underruns of the process value (set in parameters "Lower limit" and "Monitored value") has reached the threshold. Reset and acknowledge event counter. Check process conditions. Check limit monitoring and event counter settings.
AA	 	Device lifetime: maintenance demanded	Forthcoming end of configured device's lifetime. Maintenance is strongly recommended as soon as possible.





ID	Symbols	Message	Cause/action
Ab	 	Device lifetime: maintenance required	Forthcoming end of configured device's lifetime. Maintenance of device should be planned.
AE	 	Service: maintenance demanded	Forthcoming end of the configured service interval. Maintenance is strongly recommended as soon as possible.
AF	 	Service: maintenance required	Forthcoming end of the configured service interval. Maintenance of device should be planned.
AG	 	Calibration: maintenance demanded	Forthcoming end of the calibration interval. Maintenance is strongly recommended as soon as possible.
AH	 	Calibration: maintenance required	Forthcoming end of the calibration interval. Maintenance of device should be planned.
AJ	 	Limit monitoring 1 Above limit Process value alarm	Monitored value is above limit (set in parameter "Upper limit").
AL	 	Limit monitoring 1 Below limit Process value alarm	Monitored value is below limit (set in parameter "Lower limit").
An	 	Limit monitoring 2 Above limit Process value alarm	Monitored value is above limit (set in parameter "Upper limit").

ID	Symbols	Message	Cause/action
Ao	 	Limit monitoring 2 Below limit Process value alarm	Monitored value is below limit (set in parameter "Lower limit").
AP	 	Limit monitoring 3 Above limit Process value alarm	Monitored value is above limit (set in parameter "Upper limit").
Ar	 	Limit monitoring 3 Below limit Process value alarm	Monitored value is below limit (set in parameter "Lower limit").
AU	 	Event counter 1 Number overruns above threshold Process value alarm	The number of overruns of the process value (set in parameters "Upper limit" and "Monitored value") has reached the threshold. Reset and acknowledge event counter. Check process conditions. Check limit monitoring and event counter settings.
AY	 	Event counter 1 Number overruns above threshold Maintenance required	The number of overruns of the process value (set in parameters "Upper limit" and "Monitored value") has reached the threshold. Reset and acknowledge event counter. Check process conditions. Check limit monitoring and event counter settings.
b0	 	Event counter 3 Number underruns above threshold Process value alarm	The number of underruns of the process value (set in parameters "Lower limit" and "Monitored value") has reached the threshold. Reset and acknowledge event counter. Check process conditions. Check limit monitoring and event counter settings.
b1	 	Event counter 3 Number underruns above threshold Maintenance required	The number of underruns of the process value (set in parameters "Lower limit" and "Monitored value") has reached the threshold. Reset and acknowledge event counter. Check process conditions. Check limit monitoring and event counter settings.
b2*	 	Event counter 3 Number underruns above threshold Maintenance alarm	The number of underruns of the process value (set in parameters "Lower limit" and "Monitored value") has reached the threshold. Reset and acknowledge event counter. Check process conditions. Check limit monitoring and event counter settings.

ID	Symbols	Message	Cause/action
bE ¹⁾		Out of service Maintenance alarm	Output signal does not represent process value. Device mode is set to "Out of service". Repair is required. Contact Technical support.
bL*		Device restart due to unexpected program error Maintenance alarm	Watchdog function has detected an internal device error. Restart the device. If the problem persists, contact Technical support.
bn		Alarm sensor limit exceeded Process value alarm	Process value has reached the sensor limit. Review process conditions versus product specifications.
bS*		Event counter 2 Number underruns above threshold Maintenance alarm	The number of underruns of the process value (set in parameters "Lower limit" and "Monitored value") has reached the threshold. Reset and acknowledge event counter. Check process conditions. Check limit monitoring and event counter settings.
bt		Event counter 3 Number overruns above threshold Process value alarm	The number of overruns of the process value (set in parameters "Upper limit" and "Monitored value") has reached the threshold. Reset and acknowledge event counter. Check process conditions. Check limit monitoring and event counter settings.
bU		Event counter 3 Number overruns above threshold Maintenance required	The number of overruns of the process value (set in parameters "Upper limit" and "Monitored value") has reached the threshold. Reset and acknowledge event counter. Check process conditions. Check limit monitoring and event counter settings.
bY*		Event counter 3 Number overruns above threshold Maintenance alarm	The number of overruns of the process value (set in parameters "Upper limit" and "Monitored value") has reached the threshold. Reset and acknowledge event counter. Check process conditions. Check limit monitoring and event counter settings.
CA		Simulation mode Simulated or substitute value	The device is in simulation mode and one or more of its device variables are not representative of the process. Disable the simulation to return to normal operation.
Cb		Diagnostics simulated Simulated or substitute value	The device is in simulation mode. Disable the simulation to return to normal operation.

12.4 Fault codes and corrective actions

ID	Symbols	Message	Cause/action
Co ²⁾	 	Loop current fixed Manual operation	The loop current is being held at a fixed value and is not responding to process variations. Enter the loop current output value for simulation. Disable the simulation to return to normal operation.
CP ³⁾	 	Loop current in saturation Process value warning	The loop current has reached its upper (or lower) saturation limit and cannot increase (or decrease) any further. Adjust loop current scaling.
CU	 	PV status: uncertain Process value alarm	Limit is set for a negative level value, and that value is exceeded. Check for changes in process conditions or obstructions in vessel. OR Potential product damage. Sensor has malfunctioned. A replacement of sensor is recommended. Contact Technical support.
CY*	 	PV status: bad Maintenance alarm	Parameter "Fail-safe loss of echo" is set to "Fault current", and device is in loss of echo (LOE). Review process conditions versus product specifications. Use a device that fulfills your process conditions. OR The measured value is 10% higher than the physical sensor range. Review process conditions versus product specifications. Use a device that fulfills your process conditions.
FJ	 	Process conditions out of specification Process value warning	Uncertain values due to process conditions. Check installation for abnormal operating conditions.
Fn*	 	Connection failure to sensor electronics Maintenance alarm	Potential product damage. Restart the device. If error continues, sensor electronics may have a defect. Repair is required. Contact Technical support.
Fo*	 	Sensor break Maintenance alarm	Potential product damage. Sensor has malfunctioned. A replacement of sensor is recommended. Contact Technical support.
Fr	 	Internal power supply is out of allowable range Process value warning	A replacement of the device is recommended. Contact Technical support.

ID	Symbols	Message	Cause/action
FS*		Electronics defect Maintenance alarm	Defect of device electronics. A replacement of the device is recommended. Contact Technical support.
SA*		Non-volatile memory check failure Maintenance alarm	Device electronics error. Restart the device. If error continues, device electronics may have a defect. Repair is required. Contact Technical support.
Sb*		Volatile memory check failure Maintenance alarm	Device electronics error. Restart the device. If error continues, device electronics may have a defect. Repair is required. Contact Technical support.
SC*	 (red)	Invalid device configura- tion Configuration error	One or more of parameters are set to invalid values. Review configuration values and adjust as necessary.
Sd ⁴⁾		Sensor fail-safe timer expired Maintenance required	Parameter "Fail-safe loss of echo" is set to "Hold", and device is in loss of echo (LOE). Sensor is in fail-safe mode and timer has expired, based on value set in parameter "Fail-safe LOE timer". Check for changes in process conditions or obstructions in vessel.

1) bE - mA output set to **High** (see parameter "Upper fault current"). Not possible in simulation mode.

2) Co - mA output set to **Fixed current mode** (see parameter "Loop current value in multidrop mode"). Not possible in simulation mode.

3) CP - mA output set to **Saturated** (see default parameter settings for "Lower saturation limit", "Upper saturation limit"). Not possible in simulation mode.

4) Sd - Loss of echo (LOE) exists and timer has expired, therefore mA output setting is based on parameter "Fail-safe loss of echo".

12.5 Operation troubleshooting

12.5.1 Common problems

Symptom	Possible cause	Action
Display blank, transducer not pulsing	No power, incorrect power	Check voltage at terminals, check wiring connections, check wiring.
Display blank, transducer is pulsing	Loose or disconnected display	Reconnect display.
Display shows "#####" instead of current measured value	Value too large to show on device segment display	Adjust units so that a smaller value can be shown on device display, e.g. use meters instead of millimeters. See parameter Units (02-02.01) (Page 112) or Custom units (Page 150), depending on your application.
Reading fluctuates while material level is still	Material level is changing	Visually verify, if possible.
	Strong false echoes	Determine source of false echoes and relocate transmitter to avoid source.
	Incorrect damping	Adjust damping. See parameter Damping value (02-04.03) (Page 119) and Sensor damping value (03-01-04.06) (Page 136).
	Improper echo algorithm selection	Set algorithm to default. If no improvement, try a different algorithm. See parameter Algorithm (03-01-03.01) (Page 133).
	High noise levels	Verify source and minimize. See section on Noise problems (Page 174) in this chapter.
	Weak echo	Determine cause: check noise, confidence, and echo strength. See menu Signal quality (M 03-01-01) (Page 132).
	Foam on surface of material	Eliminate source of foaming. Use stilling well.
	Rapid temperature changes	If fluctuation is unacceptable, consider an alternative technology. Contact your Siemens representative.
Vapors	If fluctuation is unacceptable, consider an alternative product. Contact your Siemens representative.	

Symptom	Possible cause	Action
Reading is fixed, but material level changes or reading does not follow material level	Incorrect speed of response	Verify response speed setting is adequate for process. See parameter Response rate (Page 58) (set in "Quick commissioning wizard").
	Loss of echo condition (LOE)	Check noise, confidence, and echo strength. See menu Signal quality (M 03-01-01) (Page 132). Ensure LOE timer is not set with too short of a time period. See parameter Fail-safe LOE timer (02-04.12) (Page 121).
	Agitator blade stopped in front of transducer (false echo)	Ensure agitator is running. See note "Unavoidable false echoes from obstructions" below.
	Foam on surface of material	Eliminate source of foaming. Use stilling well.
	Incorrect algorithm used	Set algorithm to default. If no improvement, try a different algorithm. See parameter Algorithm (03-01-03.01) (Page 133).
	Transducer mounting: wrong location or incorrectly mounted	Ensure beam has a clear path to material surface. Verify transducer is not screwed into the flange too tightly.
	Unavoidable false echoes from obstructions	Relocate transmitter to ensure beam has a clear path to material surface. Use manual TVT shaping (via engineering system) or false echo suppression. See parameters Custom TVT shaper mode (Page 234) or Auto false echo suppression (03-01-06.02) (Page 139).
Accuracy varies	Vapors present in varying concentrations	Eliminate vapors or consider a different technology. Contact your Siemens representative.
	Thermal gradients	Insulate vessel.
	Calibration required	If accuracy is better when level is close to transducer and worse when level is far from transducer, perform calibration. See Auto sound velocity wizard (02-03.01) (Page 114). If reading is consistently inaccurate, use parameter Sensor offset (02-03.07) (Page 116) or perform calibration. See Sensor offset wizard (02-03.02) (Page 115).
Reading erratic	Transducer mounting: wrong location or incorrectly mounted	Ensure beam has a clear path to material surface. Verify transducer is not screwed into the flange too tightly.
	Unavoidable false echoes from obstructions	Use auto false echo suppression wizard. See parameter AFES wizard (01-02) (Page 109).
	Confidence too low	Check noise, confidence, and echo strength. See menu Signal quality (M 03-01-01) (Page 132). Ensure LOE timer is not set with too short of a time period. See parameter Fail-safe LOE timer (02-04.12) (Page 121).
	Multiple echoes	Check mounting location and verify material is not entering near range (also known as blanking or a dead zone). See parameter Near range (03-01-02.01) (Page 133).
	Noise in the application	Verify source and minimize. See section on Noise problems (Page 174) in this chapter.

Symptom	Possible cause	Action
Incorrect reading (mA output and/or displayed value)	mA function not assigned to correct measurement	Check mA assignment. See parameter PV selection (02-01.01) (Page 110).
	When device configured for volume flow: correct exponent not selected	Check configuration. For exponential volume flow applications, verify "Linearization type" is set to "Flow" and correct exponent is used. See parameter Flow exponent (02-06-05.01) (Page 127).
	Incorrect vessel or PMD dimensions	For volume application, verify vessel dimensions. See parameter Vessel shape (02-05.01) (Page 121). For volume flow application, verify PMD dimensions. See menu PMD dimensions (M 02-06-05) (Page 126).
	When device configured for custom volume or custom volume flow	For custom volume or volume flow applications, verify parameter "Linearization type" is set to "Custom" and X and Y values under parameter "Customized characteristic curve" are defined. See parameters Linearization type (02-01.03) (Page 112) and Customized characteristic curve (M 02-07.02) (Page 130).

12.5.2 Noise problems

Incorrect readings can be the result of noise problems, either acoustic or electrical, in the application. The noise present at the input to the ultrasonic receiver can be determined by using remote software (engineering system) such as SIMATIC PDM, AMS Device Manager, FC375/475, or DTM. In addition, see parameters Noise average (03-01-01.05) (Page 132) and Noise peak (03-01-01.06) (Page 132). In general, the most useful value is the average noise.

High noise decreases the maximum distance that can be measured. An average noise level greater than 15 dB may be cause for concern if the maximum operation range matches the range of the application.

12.5.2.1 Determining the noise source

Acoustical noise

To confirm that the problem is acoustical, place several layers of cardboard over the face of the transducer. If the noise is reduced, the noise is definitely acoustical.

12.5.2.2 Other noise sources

Check that low voltage cables are not run adjacent to high voltage cables or near to electrical noise generators such as variable speed drives.

The device is designed to work near heavy industrial equipment such as variable speed drives. Even so, it should not be located near high voltage wires or switch gear.

12.5.2.3 Reducing electrical noise

- Filter the noise source
- Check grounding

12.5.2.4 Reducing acoustical noise

- Move the transmitter away from the noise source
- Use a stilling well
- Relocate or insulate the noise source
- Change the frequency of the noise. Ultrasonic devices are sensitive to noise in the frequency range of the transducer employed.

12.5.3 Measurement difficulties

If the value in parameter "Fail-safe LOE timer" expires due to a measurement difficulty, the value set in parameter "Fail-safe loss of echo" displays. In rare cases, the SITRANS Probe LU240 may lock on to a false echo and report a fixed or wrong reading.

Loss of echo (LOE)

The value set in parameter "Fail-safe loss of echo" displays when the echo confidence is below the threshold value set in parameter "Echo threshold" (for long shot), or parameter "Short shot echo threshold" (for short shot).

LOE occurs when:

- The echo is lost and no echo is shown above the ambient noise (resulting in low values for parameters "Confidence"/"Short shot confidence", and "Echo signal strength"/"Short shot echo signal strength").
- Two echoes are too similar to differentiate (when BLF algorithm used) (resulting in low confidence and low echo signal strength)
- No echo can be detected within the programmed range (parameter "Far Range" can be used to extend range).

If value set in parameter "Fail-safe loss of echo" displays, check if the surface monitored is within the transmitter maximum range.

12.5.3.1 Adjusting transducer aiming

For optimum performance, adjust transducer aiming to provide the best confidence and echo strength for all material levels within the measurement range.

Displaying echoes

To check echo profiles, use an engineering system such as SIMATIC PDM, AMS, FC375/475, or DTM. For instructions on how to display an echo profile, see section Requesting an echo profile (Page 70), and for details on how to interpret an echo profile, see section Echo processing (Page 188).

Increase fail-safe timer value

Increase the value in parameter "Fail-safe LOE timer" only if the fail-safe operation will not be compromised by the larger value.

Try this only if LOE exists for short periods of time.

12.5.3.2 Fixed reading

If the reading is a fixed value, regardless of the transducer to material surface distance, ensure:

- Transducer acoustic beam is free from obstruction
- Transducer is properly aimed
- Transducer is not in contact with any object
- Material mixer (if used) is operating while the device is operating. If it is stopped, ensure that the mixer blade has not stopped directly below the transducer.

12.5.3.3 Obstructions in the sound beam

Check for (and remove if present) any acoustic beam obstruction, or relocate the transmitter.

If an obstruction cannot be removed or avoided, adjust the Time Varying Threshold (TVT) curve to reduce the echo confidence derived from the sound reflected by the obstruction. Use SIMATIC PDM to adjust the TVT curve (see Custom TVT shaper mode (Page 234)).

12.5.3.4 Nozzle mountings

If the transmitter is mounted on or in a nozzle, grind smooth any burrs or welds on the inside or open end (the end that opens into the vessel). If the problem persists, install a larger diameter or shorter length nozzle, bevel the inside of the bottom end, or cut the open end of the nozzle at a 45° angle.

If the mounting hardware is overtightened, loosen it. Overtightening changes the resonance characteristics of the transducer and can cause problems.

12.5.3.5 Set the device to ignore the bad echo

If the preceding remedies have not fixed the problem, the false echo must be ignored. If there is a static, incorrect, high level reading from the device, there is probably an obstruction reflecting a strong echo back to the transducer. If the material level never reaches that point, extend parameter "Near range" to a distance just past the obstruction.

To adjust the time-varying threshold (TVT) to ignore the bad echoes, use auto false echo suppression. If this does not correct the problem, enable custom TVT shaper mode and manually shape around false echoes. For more information, see:

- Near range (03-01-02.01) (Page 133)
- AFES wizard (Page 69)
- Auto false echo suppression and Custom TVT (Page 190)

12.5.4 Wrong reading

If the reading is erratic or jumps to some incorrect value periodically, ensure:

- Surface monitored is not beyond the transmitter's programmed range or the transmitter's maximum range
- Material is not falling into the transducer's acoustic beam
- Material is not inside the blanking distance (parameter "Near range") of the transmitter.

Types of wrong readings

If a periodic wrong reading is always the same value, see section Fixed reading (Page 176).

If the wrong reading is random, ensure the distance from the transducer to the material surface is less than value in parameter "Far range" minus one meter (i.e. ensure you are still within the measurement range programmed in the device). If the material/object monitored is outside this range, increase parameter "Far range" as required. This error is most common in OCM applications using weirs.

Liquid splashing

If the material monitored is a liquid, check for splashing in the vessel. Enter a lower value in parameter "Response rate" to stabilize the reading, or install a stilling well. (Contact Siemens representative.)

Adjust the echo algorithm

Use SIMATIC PDM to view echo profiles and to make adjustments to parameter Algorithm (03-01-03.01) (Page 133).

If multiple echoes appear on the echo profile, typical of a flat material profile (especially if the vessel top is domed), use the "True first echo" algorithm. Also, if the true echo has jagged peaks, use parameter "Reform echo".

Should a stable measurement still not be attainable, contact Siemens representative.

12.5.5 Transducer ringing

If the transducer is mounted too tightly, or if it is mounted so that its side touches something (such as a vessel wall, or standpipe), the resonance characteristics of the transducer change and this can cause problems. Hand tighten only. PTFE tape is not recommended as it reduces friction resulting in a tighter connection that can lead to ringing.

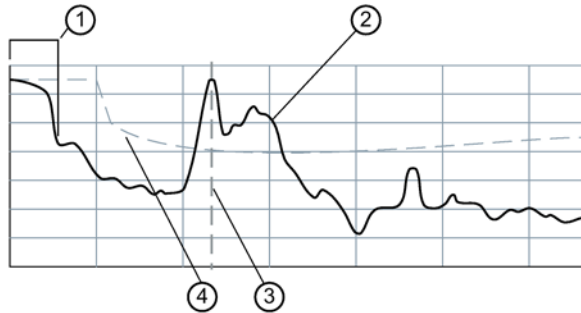

- ① Ring down
- ② Echo profile
- ③ Time of correct echo
- ④ TVT curve

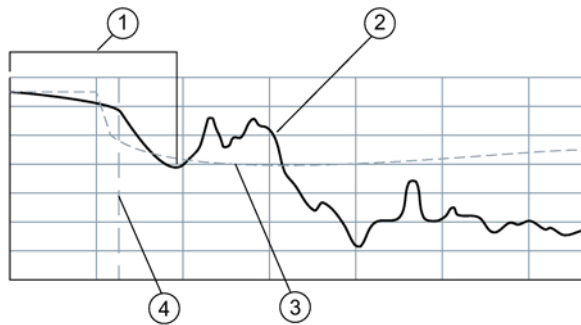

- ① Ring down
- ② Echo profile
- ③ TVT curve
- ④ Time of correct echo

Ring down times that extend past the near range area can be interpreted by the device as the material level and are characterized by a steady high level being reported.

12.5.6 Echo profile display and Trend display

To assist in troubleshooting echo profiles, pan and zoom options are available. See Echo profile (Page 231).

A trend display is available with pan and zoom options. See Process values (Page 237).

Technical data

Note

Device specifications

Siemens makes every attempt to ensure the accuracy of these specifications but reserves the right to change them at any time.

Note

Device-specific approvals

Always refer to nameplates on the device for device-specific approvals.

Note

Power

Nominal 24 V DC at maximum 550 Ohm. For other configurations, see Loop power (Page 200).

13.1 Power

Supply voltage	30 V DC maximum
Signal range	4 to 20 mA
Startup current	3.6 mA maximum

SITRANS Probe LU240 with Explosion protection Ex ia	
U _i (Input voltage)	30 V DC maximum
I _i (Input current)	120 mA DC maximum
P _i (Input power)	0.8 W
C _i (Effective inner capacitance)	0 nF
L _i (Effective inner inductance)	0 mH

13.2 Performance

Reference operating conditions (in accordance with IEC 60770-1)	
Ambient temperature	+15 to +25 °C
Humidity	45 to 75% relative humidity
Ambient pressure	860 to 1060 mbar

Measurement accuracy (in accordance with IEC 60770-1)	
Measured error (accuracy)	+/- the greater of 0.15% of range or 6mm (accuracy valid from 0.25 m)
Non-repeatability	≤ 3 mm (0.12") (included in accuracy specification)
Deadband (resolution)	≤ 3 mm (0.12") (included in accuracy specification)
Hysteresis error	Not applicable

Analog output accuracy (in accordance with IEC 60770-1)	
Measured error (accuracy)	0.02% of 4..20 mA span (including hysteresis and non-repeatability)
Non-repeatability	<1 µA (included in accuracy specification)
Deadband (resolution)	<1 µA (included in accuracy specification)
Hysteresis error	Not applicable

Frequency	54 KHz
Measurement range ¹⁾	<ul style="list-style-type: none"> • Up to 6 m (6 m device) • Up to 12 m (12 m device)
Blanking distance	0.2 m (0.66 ft)
Update time at 4 mA	<4 s
Beam angle	10° at -3 dB boundary
Temperature compensation	Integrated to compensate over temperature range
Memory	Non-volatile EEPROM, no battery required

¹⁾ Reference point for measurement is the transducer face (also known as sensor reference point).

13.3 Interface

HART	Standard, integral to analog output
Configuration	Local buttons, or engineering system such as Siemens SIMATIC PDM (via PC)
Display (local)	Multi-segment alphanumeric liquid crystal, with bar graph (representing Level)

13.4 Outputs

Analog output	<ul style="list-style-type: none"> • 4 to 20 mA
	<ul style="list-style-type: none"> • 800 ohms maximum
	<ul style="list-style-type: none"> • ± 0.02 mA accuracy • Resolution of $< 1 \mu\text{A}$

13.5 Construction

Process connections	<ul style="list-style-type: none"> • 2" NPT (ASME B1.20.1) (tapered thread) • R 2" [(BSPT), EN 10226-1] (tapered thread) • G 2" [(BSPP), EN ISO 228-1] (parallel thread) 	
Transducer/nosecone	<ul style="list-style-type: none"> • Buna-N seal • PVDF (polyvinylidene fluoride) • ETFE (ethylene-tetrafluoroethylene) 	
Enclosure	Body material	Plastic (PBT/PC - polybutylene terephthalate/polycarbonate)
	Electrical connections/cable entries	<ul style="list-style-type: none"> • 2 x M20 x 1.5 (one general purpose cable gland and one blocking plug provided) • 1 x 1/2" NPT
	Ingress protection	<ul style="list-style-type: none"> • IP66, TYPE 4X • IP68, TYPE 6
Clear lid	Plastic (PBT/PC - polybutylene terephthalate/polycarbonate)	
Blind lid	Plastic (PC - polycarbonate)	
Weight	0.93 kg	
Installation torques	Cable gland to enclosure (Siemens supplied, metric)	10 Nm

Note

Specific configuration requirements

Check the ambient and operating temperatures under Operating conditions (Page 182) and Process (Page 182); also check Approvals (Page 183) for the specific configuration you are about to use or install.

Use approved cable gland/conduit seal to maintain Type 4X, Type 6, IP66, IP68 ratings.

For dimensions of parts listed above, see Dimension drawings (Page 185).

13.6 Operating conditions

Location	Indoor/outdoor	
Altitude	5000 m (16,404 ft) maximum	
Vibration resistance	0.5 g at frequencies from 10 Hz to 100 Hz	
Bump/shock resistance	25 g	
Ambient temperature	Storage	-40 to +85 °C
	Operating	-40 to +80 °C
Relative humidity	Suitable for outdoor (TYPE 4X, TYPE 6, IP66, IP68 enclosure)	
Installation category	I	
Pollution degree	4	
EMC performance	Emission	EN 55011/CISPR-11
	Immunity	EN/IEC 61326-1 (Industry)

13.7 Process

Temperature (at flange or threads)	-40 to +85 °C (-40 to +185 °F)
Pressure (vessel)	0.5 bar g/7.25 psi g

13.8 Communication

Communication type	<ul style="list-style-type: none"> • HART • 4 to 20 mA
Supported engineering systems	<ul style="list-style-type: none"> • SIMATIC PDM • AMS Device Manager • FC375/FC475 • FDT (such as Pactware, or Fieldcare) • SITRANS library for use with PCS-7

13.9 Approvals

General	FM/cCSA _{US} , CE, RCM		
Hazardous	Intrinsic safety	Europe	ATEX II 1 GD, Ex ia IIC T4 Ga
		International	IECEX SIR 18.0013X, Ex ia IIC T4 Ga
		US/Canada	FM/CSA Class I, Div.1, Groups A, B, C, D Class II, Div.1, Groups E, F, G Class III T4
		Brazil	INMETRO Ex ia IIC T4 Ga
		China	NEPSI Ex ia IIC T4 Ga
		South Africa	SABS Ex ia IIC Tx Ga
		Non-incendive	US

Dimension drawings

14.1 SITRANS Probe LU240 dimensions

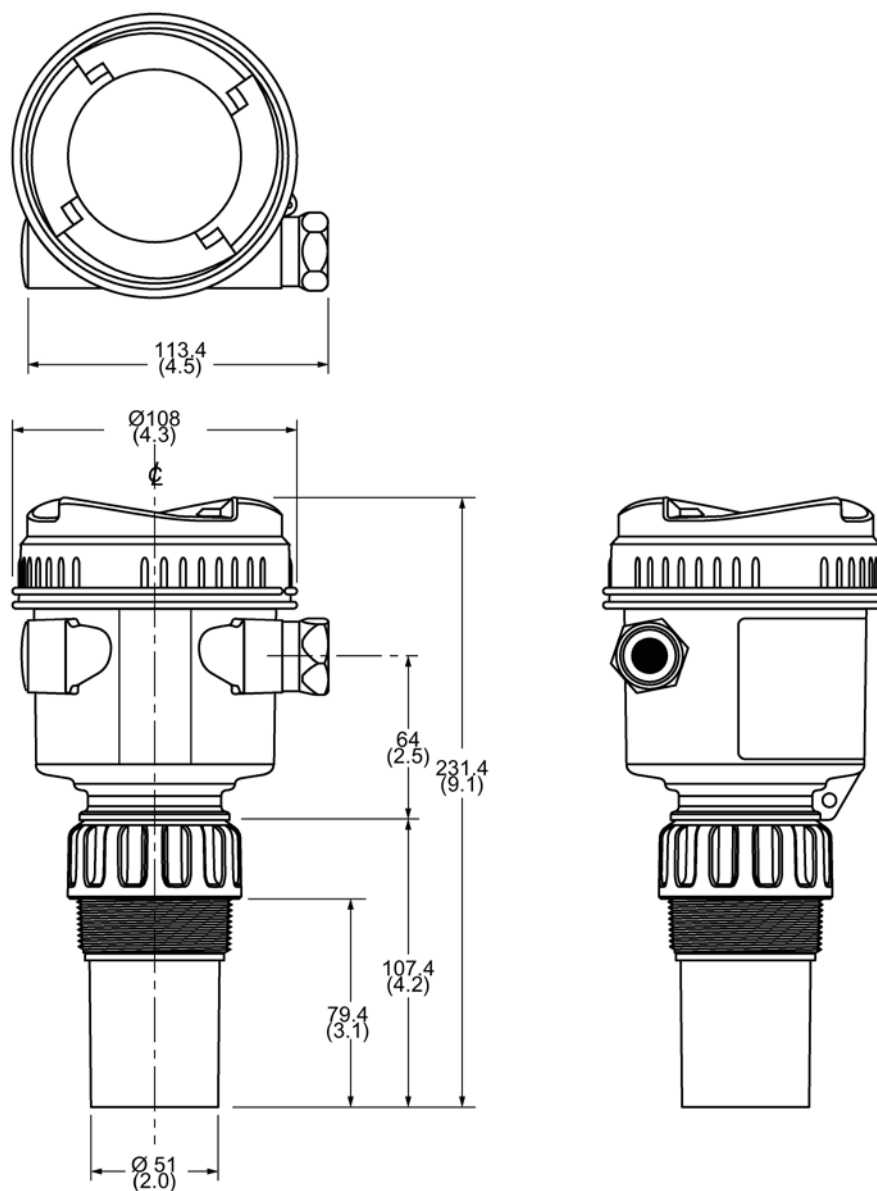

Dimensions in mm (inch)

14.2 Flange adaptor (optional)

SITRANS Probe LU240 can be fitted with the optional 3" (80 mm) flange adaptor for mating to 3" ANSI, DIN 65PN10, and JIS 10K3B flanges.

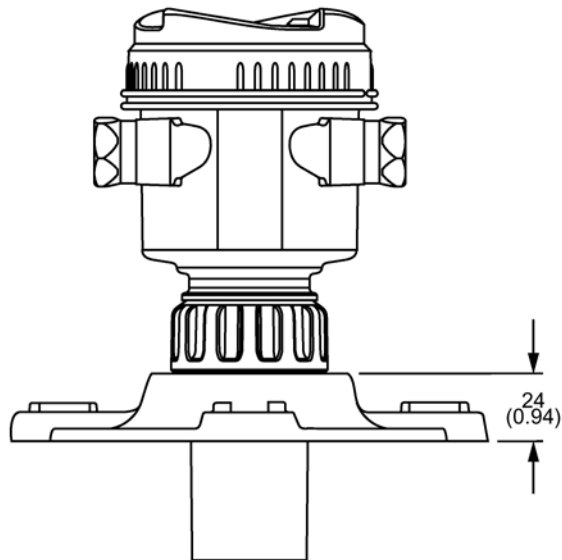
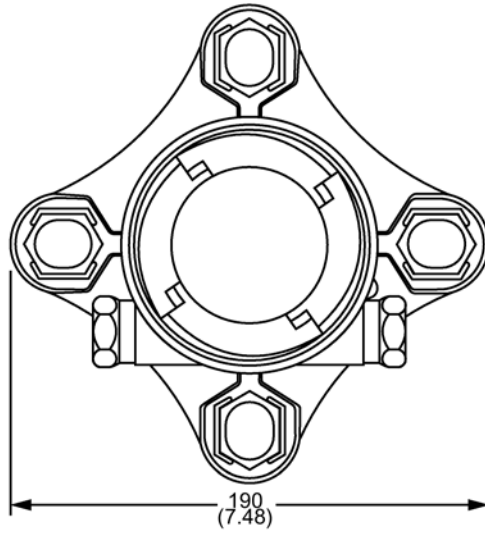

Dimensions in mm (inch)

Technical reference

A.1 Principle of operation

The transducer emits a series of ultrasonic pulses: each pulse is reflected as an echo from the material and sensed by the transducer. The echo is processed by the device using Siemens' proven Process Intelligence techniques. Filtering is applied to help discriminate between the true echo from the material, and false echoes from acoustic and electrical noises and agitator blades in motion.

The time for the pulse to travel to the material and back is temperature compensated and then converted into distance for display and mA output.

A.1.1 Process values

The primary variable (PV) and the secondary variable (SV) (set in PV selection (02-01.01) (Page 110), and SV selection (02-01.02) (Page 112)), can be selected from one of five process values:

- **Level** - difference between material level and lower calibration point
- **Space** - difference between material level and upper calibration point
- **Distance** - difference between material level and sensor reference point
- **Volume** - volume of material based on level
- **Volume flow** - flowrate in an open channel, based on level (open channel level also known as head)
- **Custom**

In addition to the selections above, the secondary variable (SV) can also be set to **Sensor temperature**.

A.1.2 Transmit pulse

The transmit pulse consists of one or more electrical "shot" pulses, which are supplied to the transducer. The transducer fires an acoustic "shot" for each electrical pulse supplied. After each shot is fired, sufficient time is provided for echo (shot reflection) reception before the next shot is fired. After all shots of the transmit pulse are fired, the resultant echoes are processed. The transmit pulse shot number, duration, delay, and associated measurement range are defined by parameters under Setup (M 02) (Page 110).

A.2 Echo processing

Echo processing consists of echo enhancement, true echo selection, and selected echo verification.

Echo enhancement is achieved by filtering ¹⁾ and reforming ²⁾ the echo profile. The true echo (echo reflected by the intended target) is selected when that portion of the echo profile meets the evaluation criteria of Process Intelligence. Insignificant portions of the echo profile outside of the measurement range ³⁾, below the TVT curve ⁴⁾, and less than the confidence threshold ⁵⁾, are automatically disregarded. The remaining portions of the echo profile are evaluated using the selected algorithm ⁶⁾. The echo profile portion providing the best echo confidence ⁷⁾ is selected.

True echo verification is automatic. The position (relation in time after transmit) of the new echo is compared to that of the previously accepted echo. When the new echo is within the echo lock window ⁸⁾, it is accepted, and displays and outputs are updated per the rate parameters ⁹⁾. If the new echo is outside of the window, it is not accepted until echo lock requirements ¹⁰⁾ are satisfied.

¹⁾ Narrow echo filter (03-01-04.01) (Page 135) ⁶⁾ Algorithm (03-01-03.01) (Page 133)

²⁾ Reform echo (03-01-04.02) (Page 135) ⁷⁾ Confidence (03-01-01.02) (Page 132)

³⁾ Lower calibration point (02-03.03) (Page 116) ⁸⁾ Echo lock window (03-01-05.02) (Page 137)

⁴⁾ Custom TVT shaper mode (Page 234) ⁹⁾ Fill rate (02-02.02) (Page 113) and Empty rate (02-02.03) (Page 113)

⁵⁾ Echo threshold (03-01-03.03) (Page 134) ¹⁰⁾ Echo lock (03-01-05.01) (Page 137)

A.2.1 Echo selection

A.2.1.1 TVT (time varying threshold) curves

A TVT curve describes a threshold below which any echoes will be ignored. The default TVT curve is used, until Auto false echo suppression (03-01-06.02) (Page 139) and Auto false echo suppression range (03-01-06.03) (Page 140) are used to create a new 'learned TVT curve'.

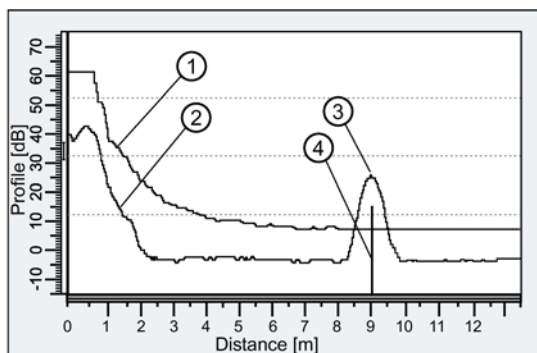

- ① Default TVT
- ② Echo profile
- ③ Material level
- ④ Echo marker

A TVT hovers above the echo profile to screen out unwanted reflections (false echoes). In most cases the material echo is the only one which rises above the default TVT. In a vessel with obstructions, a false echo may occur. For more information, see Auto false echo suppression and Custom TVT (Page 190).

The device characterizes all echoes that rise above the TVT as potential good echoes. Each peak is assigned a rating based on its strength, area, height above the TVT, and reliability, among other characteristics.

A.2.1.2 Algorithm

The true echo is selected based on the setting for the echo selection algorithm. (A full list of supported algorithms can be found at Algorithm (03-01-03.01) (Page 133).) All algorithms ultimately use confidence to select the true echo.

Below are the preferred algorithm types because they provide the best echo selection results in most applications. Other algorithms may produce better results in specialized applications, but they should only be used after consulting an experienced technical expert.

Algorithm		Echo determination	Suggested use
ALF	Area largest first echo	Selects the echo with the highest confidence value based on the three criterion (widest, highest, and first).	Use in mid to long range solids applications where the material return echo is wide and large, and where competing smaller echoes challenge BLF.
L	Largest echo	Selects the largest echo above the TVT curve.	Use in long range liquids applications with large (tall) material return echoes.
AL	Largest echo area	Selects the echo with the largest area.	Use in solids applications with a high angle of repose.

Algorithm		Echo determination	Suggested use
BLF	Best echo of the first and largest echo	Selects the echo (first and highest) with the highest confidence value.	Default and most commonly used. Use in all short to mid range general liquids and solids applications where there is a relatively large (tall), sharp echo.
TF	True first echo	Selects the first echo that crosses TVT curve.	Use in liquids applications free of obstructions when confidence of first echo is high.

A.2.1.3 Confidence

Confidence (03-01-01.02) (Page 132) describes the quality of an echo. Higher values represent higher quality.

A.2.1.4 Echo threshold

Echo threshold (03-01-03.03) (Page 134) defines the minimum confidence value required for an echo to be accepted as valid and evaluated.

A.2.1.5 Auto false echo suppression and Custom TVT

If you have a vessel with known obstructions, use auto false echo suppression to prevent false echo detection. If the device displays a false high level, or the reading is fluctuating between the correct level and a false high level, this typically is the result of obstructions in the vessel.

False echoes can be caused by an obstruction in the transducer shot path (such as pipes, ladders, chains). Such false echoes may rise above the default TVT curve.

The device takes a profile for the whole measurement range and the TVT is shaped around all echoes present at that moment.

Parameter Auto false echo suppression range (03-01-06.03) (Page 140) specifies the range within which the learned TVT is applied. Default TVT is applied over the remainder of the measurement range.

The material level should be below all known obstructions at the moment when the TVT is learned. Ideally the vessel should be empty or almost empty.

AFES range must be set to a distance shorter than the distance to the material level when the environment was learned, to avoid the material echo being screened out.

Note

TVT "Learn"

Although the parameters "Auto false echo suppression" and "Auto false echo suppression range" may be adjusted on their own, the "Auto false echo suppression wizard" must be used to "learn" the TVT.

Note

AFES automatically disabled

The device will automatically reset parameter "Auto false echo suppression" to "Disabled" under the following conditions:

- Parameter "Auto false echo suppression" is manually enabled, and an initial device TVT learn is *never* requested (via AFES wizard)
- Parameter "Auto false echo suppression" is enabled (either manually or automatically based on previous TVT learn using AFES wizard), and a new TVT learn request fails (for example, due to a power failure during the learn process).

To avoid situations where AFES is disabled by the device, use "Auto false echo suppression wizard" initially. The wizard will store a learned TVT and enable AFES.

If AFES is later disabled then re-enabled, the stored TVT will be used.

Note

Persistent false echoes

If, after using AFES, a problem with false echoes persists, ensure that the learned TVT is representative.

- Review settings for other tuning and filter adjustment parameters (such as "Narrow echo filter", "Reform echo", "Hover level", etc.) before readjusting auto false echo suppression.
-

Example before Auto false echo suppression

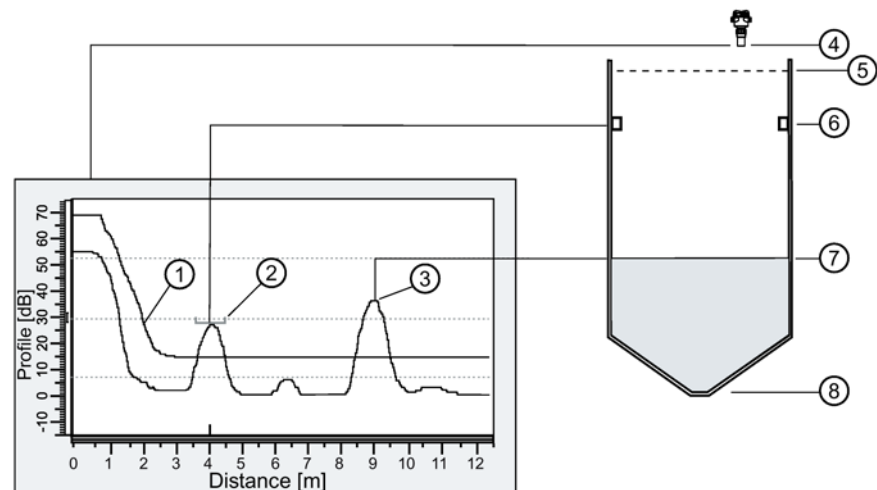

- | | |
|--------------------------|-----------------------------------|
| ① Default TVT | ⑤ Upper calibration point = 0.5 m |
| ② False echo | ⑥ Obstruction at 4 m |
| ③ Material echo | ⑦ Material level at 9 m |
| ④ Sensor reference point | ⑧ Lower calibration point = 12 m |

Example after Auto false echo suppression

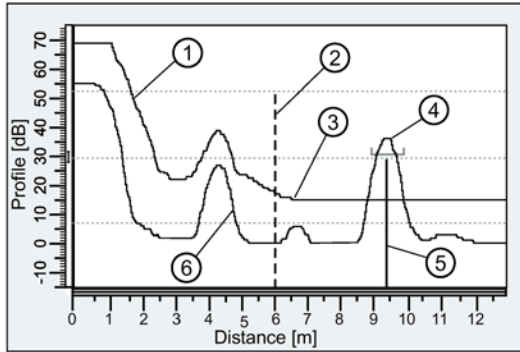

- ① Learned TVT (applied within AFES range)
- ② Auto false echo suppression range (set to 6 m)
- ③ Default TVT (applied outside AFES range)
- ④ Material echo
- ⑤ Echo marker
- ⑥ False echo

Custom TVT breakpoints

This feature allows you to manually adjust the TVT to avoid false echoes caused by obstructions. The feature is available remotely, using an engineering system such as SIMATIC PDM. "Enable" parameter "Custom TVT shaper mode", then customize up to 40 breakpoints. See Custom TVT breakpoints (Page 232).

A.2.2 Measurement range

The crystal which produces the transmit pulse has to stop vibrating before it can receive an echo. The blanking distance (set in Near range (03-01-02.01) (Page 133)) is the space in front of the transducer face where level measurement is not possible, because within that distance, the echo would return before the vibration had ceased. The reference point for measuring the blanking distance is the transducer face (sensor reference point).

Near range (03-01-02.01) (Page 133) programs the device to ignore the area in front of the transducer. The default value is 0.2 m (1 ft) from the sensor reference point. Near range can be increased from its factory default, but it is generally recommended that Auto false echo suppression (Page 190) be used instead.

Far range (03-01-02.02) (Page 133) can be used in applications where the base of the vessel is conical or parabolic. A reliable echo may be available below the vessel empty distance (Lower calibration point (02-03.03) (Page 116)) due to an indirect reflection path. Increasing Far range by 30% or 40% can provide stable empty vessel readings.

A.2.3 Measurement response

Note

Rate parameters

Parameter "Response rate" is set in Quick commissioning (Page 47), and the related fill and empty rate parameters are always defined in meters per minute.

Response rate (Page 52) limits the maximum rate at which the display and output respond to changes in the measurement. There are three preset options: slow (default), medium, and fast. Once the real process fill/empty rate (m/min by default) is established, a response rate can be selected that is slightly higher than the application rate. "Response rate" automatically adjusts the three rate parameters that affect the output response rate.

When "Response rate" set to:	"Fill rate" (02-02.02)/"Empty rate" (02-02.03) automatically adjust to:	"Damping value" (02-04.03) automatically adjusts to:
Slow	0.1 m/min	100.0 s
Medium	1.0 m/min	50.0 s
Fast	10.0 m/min	1.0 s

A.2.3.1 Damping

Damping value (02-04.03) (Page 119) smooths out the response to a sudden change in level. This is an exponential filter and the engineering unit is always in seconds.

In five time constants, the output rises exponentially: from 63.2% of the change in the first time constant, to almost 100% of the change by the end of the fifth time constant.

Damping example

Time constant = 2 seconds

Input (level) change = 2 meters

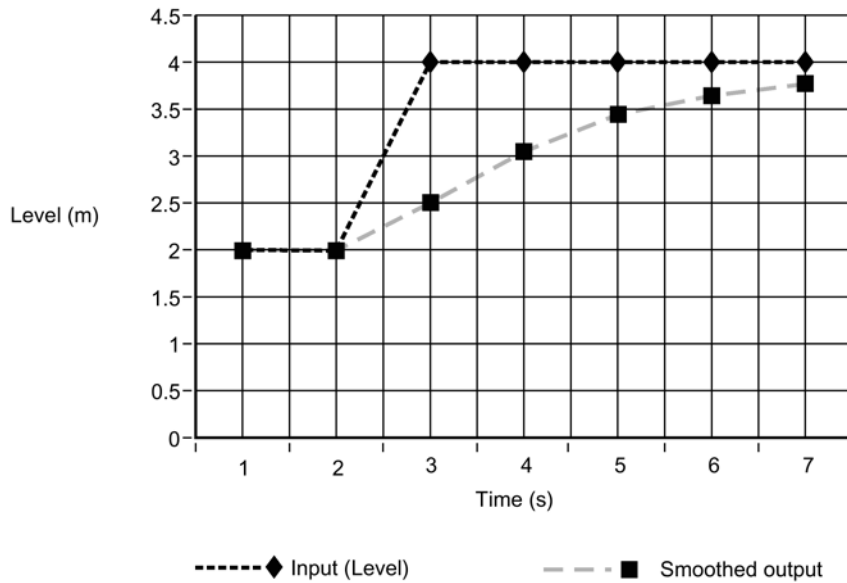

Note

The parameter "Damping value" can be set to zero in order to display measurement readings as fast as fill/empty rates permit. Parameters "Fill rate" and "Empty rate" work in conjunction with parameter "Damping value", therefore if readings are slow to respond to changes, check that fill and empty rates are set to values greater than or equal to the desired response rate.

For more information, see Sensor damping value (03-01-04.06) (Page 136).

A.3 Current output

The current output is proportional to material level in the range 4 to 20 mA. 0% and 100% are percentages of the full-scale reading (m, cm, mm, ft, in). Typically, current output is set so that 4 mA equals 0% and 20 mA equals 100%.

PV selection (02-01.01) (Page 110) controls the current output and applies any relevant scaling. By default it is set to Distance. Other options are Space, Distance, Volume, Volume flow, or Custom. (Use Loop test (M 03-03) (Page 141) to test the functioning of the loop.)

The current output can also be set to report a certain mA value when the device is in an error condition. Set the desired mA value in parameter "Upper fault current" (e.g. 22.5 mA) or "Lower fault current" (e.g. 3.8 mA). Next, go to parameter "Fault current" and select option "Upper fault current" or "Lower fault current" (whichever one includes the desired mA value).

You can also set the mA output to report when the device is in an error condition and the fail-safe timer has expired. Set parameter "Fail-safe loss of echo" to use last valid reading or value in parameter "Fault current".

A.3.1 Fail-safe

Fail-safe settings are used to put the process into a safe mode of operation in the event of a fault or failure. Fault current (02-04.10) (Page 121) sets the value (as displayed in Loop current, in **measurement view** of local display) to be reported in the event of a fault. Set this value so that a loss of signal triggers the same response as an unsafe level.

Loss of echo (LOE)

A loss of echo (LOE) fault occurs when the calculated measurement is considered unreliable because the echo Confidence value has dropped below the Echo threshold.

For an LOE fault, Fail-safe LOE timer (02-04.12) (Page 121) determines the length of time a loss of echo (LOE) condition will persist before a fail-safe state is activated. The default setting is 100 seconds.

Fail-safe loss of echo (02-04.11) (Page 121) determines the mA value (corresponding to the selected PV) to be reported when Fail-safe LOE timer expires. Choose between the last valid reading ("Hold" = default) or the value set in parameter "Fault current".

Upon receiving a reliable echo, the loss of echo condition is aborted, the Maintenance required icon and error message are cleared, and the current output returns to the current material level.

If two faults are present at the same time, the device status indicator and text for the highest priority fault will display. For example, if both loss of echo (PV status: uncertain) and broken cable (Sensor break) faults are present, the broken cable fault will display.

Failure

Sensor break (Fo)



Out of specification

PV status: uncertain (CU)



A.4 Distance calculation

To calculate the transducer to material level (object) distance, the transmission medium (atmosphere) Sound velocity (02-03.08) (Page 117) is multiplied by the acoustic transmission to reception time period. This result is divided by two to calculate the one-way distance.

Distance = Sound velocity x Time / 2

The reading displayed is the result of performing any additional modification to the calculated distance as determined by:

- PV selection (02-01.01) (Page 110)
- Volume units (02-05.04) (Page 123)
- Volume conversion parameters - Volume (M 02-05) (Page 121), and Sensor offset (02-03.07) (Page 116)
- Volume flow parameters - Volume flow (M 02-06) (Page 124)

A.4.1 Sound velocity

The sound velocity of the transmission medium is affected by the type, temperature, and vapor pressure of the gas or vapor present. As preset, the device assumes the vessel atmosphere is air at 20 °C (68 °F). Unless altered, the sound velocity used for the distance calculation is 344.1 m/s (1129 ft/s).

Variable air temperature is automatically compensated by use of a temperature sensor in the transducer of the device. If the transmitter is exposed to direct sunlight, use of a sunshield is recommended.

Atmosphere composition other than air can pose a challenge for ultrasonic level measurement. However, excellent results may be obtained by performing a sound velocity calibration (Auto sound velocity wizard (02-03.01) (Page 114)) if the atmosphere is:

- Homogenous (well-mixed)
- At a fixed temperature
- Under constant vapor pressure

The device automatic temperature compensation is based on the sound velocity/temperature characteristics of "air" and may not be suitable for the atmosphere present. If the atmosphere temperature is variable, perform frequent sound velocity calibrations to optimize measurement accuracy.

Sound velocity calibration frequency may be determined with experience. If the Sound velocity (02-03.08) (Page 117) in two or more vessels is always similar, future calibrations may be performed on one vessel and the resultant sound velocity entered directly for the other vessel(s).

When the sound velocity of a vessel atmosphere is found to be repeatable at specific temperatures, a chart or curve may be developed. Then, rather than performing a sound velocity calibration each time the vessel temperature changes significantly, the anticipated sound velocity may be entered directly.

Note

Changing sound velocity

Sound velocity can be changed via remote engineering system. In PDM, the parameter "Sound velocity (20 °C)" can be found in "**Setup > Calibration**".

A.5 Volume calculation

The device provides a variety of volume calculation features such as:

- Vessel shape (02-05.01) (Page 121)
- Upper scaling point (02-05.05) (Page 124)
- Vessel dimension A (02-05.02) (Page 123)
- Vessel dimension L (02-05.03) (Page 123)

If the vessel does not match any of the preset vessel shapes, a custom volume calculation may be used. Use the level/volume graph or chart provided by the vessel fabricator (or create one based on the vessel dimensions). Based on the graph, select the level versus volume breakpoints (X-value, Y-value) to be entered (maximum of 32) under menu Customized characteristic curve (M 02-07.02) (Page 130). Generally, the more breakpoints entered, the greater the accuracy.

Note

Custom application

The "Customized characteristic curve" menu is only visible when parameter "Operation" (via the quick commissioning wizard), or "PV selection" in the **navigation view**) is set to 'Custom'.

Creating a customized characteristic curve

Breakpoint number	Level breakpoint (X-value n)	Volume breakpoint (Y-value n)
1	0 m	0
2	1 m	200
3	2 m	1200
4	6 m	2600

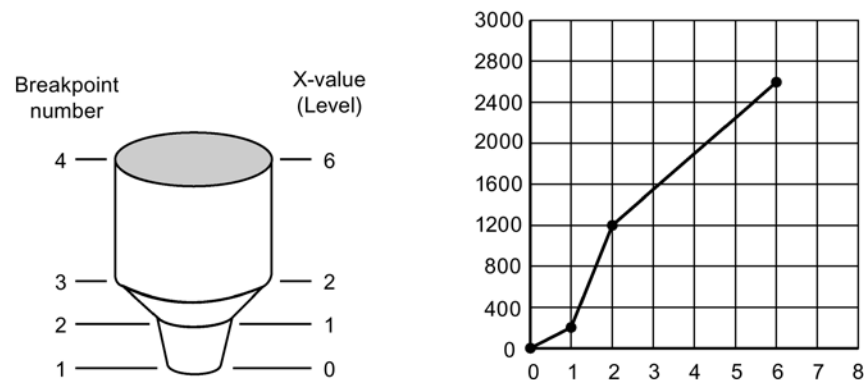

This volume calculation creates a piece-wise linear approximation of the level/volume curve, providing best results if the curve has sharp angles joining relatively linear sections.

Enter a level breakpoint (X-value) at each point where the vessel shape bends sharply (minimum of two). For shapes that are mostly linear but include one or more arcs, enter numerous breakpoints along the arc for best volume calculation accuracy.

A.6 Volume flow calculation

Special emphasis has been placed on providing the most accurate flow calculations possible. To this end, specific routines have been written to comply with the British Standards Institute's Specifications BS-3680. These routines calculate correction factors taking into account second order effects, such as approach velocity and boundary layer.

If the PMD does not match any of the preset PMD calculations, or if a PMD is not used, a custom flow calculation may be used. Use the level/volume flow graph or chart provided by the PMD fabricator (or create one based on the PMD or channel dimensions). Based on the graph, select the level versus volume flow breakpoints (X-value, Y-value) to be entered (maximum of 32) under menu Custom (M 02-07) (Page 129). Generally, the more breakpoints entered, the greater the accuracy.

Note

Custom application

The "Customized characteristic curve" menu is only visible when parameter "Operation" (via "Quick commissioning wizard"), or "PV selection" in the **navigation view**) is set to 'Custom'.

Creating a customized characteristic curve

Example: V-notch weir

Breakpoint number	Level breakpoint (X-value n)	Volume flow breakpoint (Y-value n)
4	0.4 m	113.5
3	0.3 m	55.3
2	0.2 m	20.07
1	0 m	0

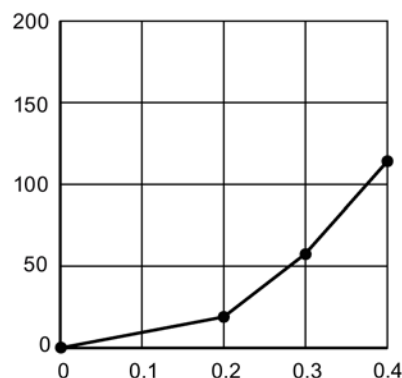
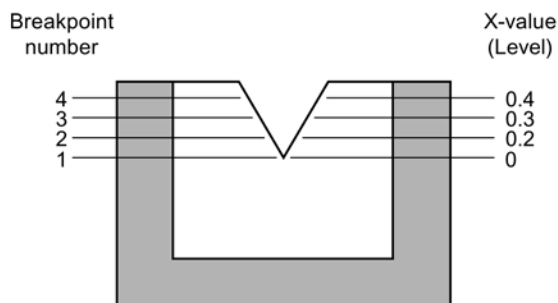

This calculation creates a piece-wise linear approximation of the level/flow curve, providing best results if the curve is non-linear and there are no sharp angles.

Select at least enough breakpoints from the curve to satisfy the following:

- Two breakpoints very near the minimum level
- Minimum two breakpoints near mid-section of PMD
- Two breakpoints very near the maximum level

For combination curves, enter at least two breakpoints immediately before and after any sharp angle (as well as one breakpoint exactly at the angle) on the curve.

A.6.1 Method of flow calculation

The device can be programmed to use either of two methods for calculating volume flow from the level measurement: absolute or ratiometric. The result is the same regardless of the method used. The main difference is the information that must be entered in order for the device to carry out the calculation. Refer to Primary measuring device (02-06.01) (Page 124) and PMD dimensions (M 02-06-05) (Page 126) for a list of information required.

For the ratiometric method, it is usually sufficient that the user know the volume flow rate (Q_{cal}) which occurs at maximum level (H_{cal}).

On the other hand, absolute calculations require that the user enter information such as the physical dimensions of the PMD and the constant relating to units of measure for both linear dimensions and volume flow rates.

Example:

The general formula for volume flow through a single exponent PMD is:

$$Q = KH^x$$

The specific formula for volume flow through a 45 ° V-notch weir is:

$$cfs = 1.03H^{2.5}$$

Thus: Q = flow in cubic feet per second

K = constant of 1.03

H = head in feet ('Head' also referred to as 'Level'. For maximum level, see Upper scaling point (02-06.04) (Page 125).)

The absolute method is not applicable to the following:

- Palmer-Bowlus flume
- H-flume

Note

Accurate flow calculation

In a volume flow application using **exponential** device, and **absolute** method of flow calculation, the following must be consistent for flow calculation to be valid:

- Engineering units for level (parameter "Units")
 - Engineering units for volume flow (parameter "Volume flow units")
 - Constant factor (parameter "K-factor").
-

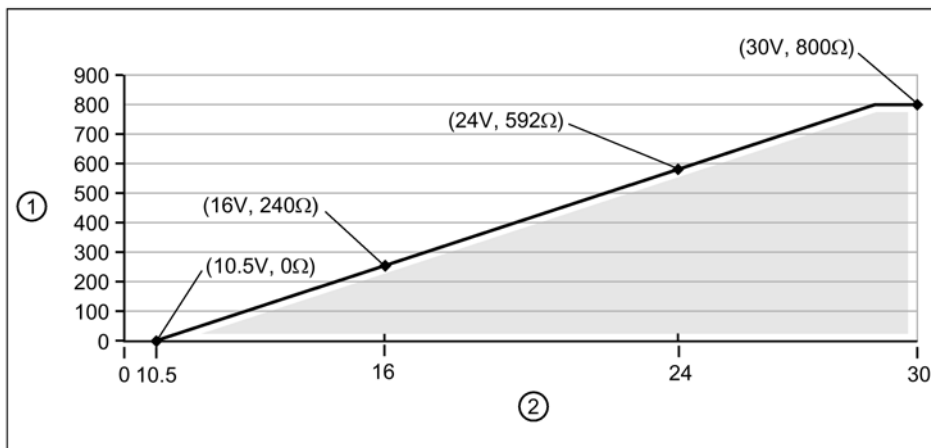

- ① Loop resistance - R_L
- ② Loop voltage - V_L

Note

HART communication

For example as per graph, when using HART communication with 240 Ohms of Loop resistance (R_L), the minimum Loop voltage (V_L) is 16 V DC.

A.10 Hazardous area installations

A.10.1 Intrinsically safe model

Under the entity evaluation concept, SITRANS Probe LU240 has the following characteristics:

(input voltage) U_i	= 30 V DC (maximum)
(input current) I_i	= 120 mA DC (maximum)
(input power) P_i	= 0.8 W

Definition:

The Entity Concept allows interconnection of intrinsically safe apparatus to associated apparatus not specifically examined in such combination. The criteria for interconnection is that the voltage and current which intrinsically safe apparatus can receive and remain intrinsically safe, considering faults, must be equal to or greater than the output voltage (U_o) and output current (I_o) levels which can be delivered by the associated apparatus, considering faults and applicable factors. In addition, the maximum unprotected capacitance (C_i) and Inductance (L_i) of the intrinsically safe apparatus, including interconnecting wiring, must be equal to or less than the capacitance and inductance which can be safely connected to associated apparatus.

FM/CSA

- Approved dust-tight and water-tight conduit seals are required for outdoor IP66 (TYPE 4X), and/or IP68 (TYPE 6) locations.
- The maximum voltage of the non-intrinsically safe apparatus must not exceed 250 V rms.

Hazardous area
Zone 0,1, or 2

Non-hazardous area

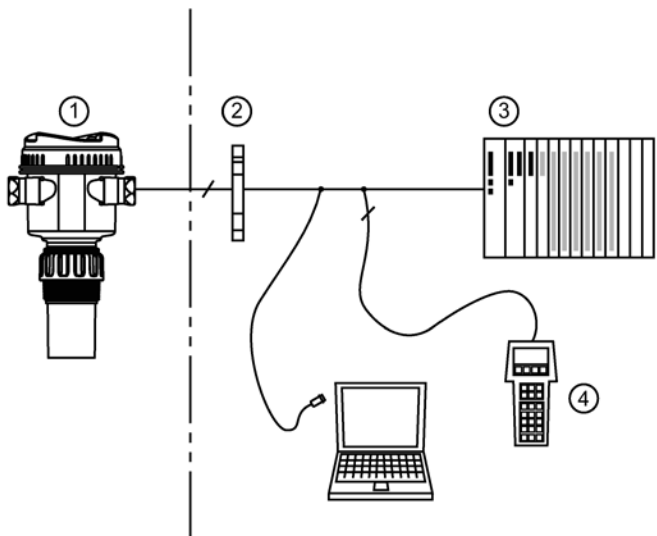

- ① Load 4...20 mA
- ② Certified barrier
- ③ PLC (active)
- ④ HART handheld communicator

EU equivalency

Any zener diode safety barrier, certified by an EU approved certification body to [EEx ia] IIC, its output voltage (U_o) not exceeding 30 V and its output current (I_o) limited by load resistance (R_o); such that $I_o = U_o / R_o$, does not exceed 120 mA.

IS safety barrier selection

Selecting a suitable barrier or power supply requires knowledge about Intrinsic Safety and the application. It is the responsibility of the installer to ensure that the intrinsically safe installation complies with both the apparatus approval requirements and the relevant national code of practice.

How to select a passive barrier for SITRANS Probe LU240

1. Make sure that the barrier safety description is suitable for the SITRANS Probe LU240 Intrinsically Safe (IS) input parameters.
2. Determine the maximum end-to-end resistance of the barrier (R_{e-e}) from the data sheet.

3. Determine other loop resistance (R_{loop}): for example, sense resistance, displays, and/or PLC inputs.
4. Calculate $R_{working} = R_{e-e} + R_{loop}$.
5. Determine any non-linear voltage drops due to the barrier ($V_{barrier}$) from the barrier data sheet (for example, voltage drops due to diodes).
6. Calculate $V_{working} = V_{supply} - V_{barrier}$.
7. Using $V_{working}$ and $R_{working}$, confirm that operation is within the shaded area of the graph showing loop resistance versus loop voltage, under Loop power (Page 200).

HART communication

Highway Addressable Remote Transducer (HART) is an industrial protocol that is superimposed on the 4 to 20 mA signal. It is an open standard and full details about HART can be obtained from:

- HART Communication Foundation (<https://fieldcommgroup.org/>)

SITRANS Probe LU240 can be configured over the HART network using the HART Communicator 375/475 by Emerson, or a software package. The recommended software package is the SIMATIC Process Device Manager (PDM) by Siemens.

HART version

SITRANS Probe LU240 conforms to HART revision 7.6.

HART multi-drop mode

HART multi-drop mode allows the connection of multiple field devices via HART. To setup multi-drop mode via a HART network, the polling address must be set.

To set up multi-drop mode via the HMI:

1. Set the polling address (Polling address (04.01) (Page 144))
2. Set the device mode (Loop current mode (02-04.01) (Page 118))
3. Set the mA value for multi-drop mode (Loop current value in multidrop mode (02-04.02) (Page 119))

SIMATIC PDM

This software package is designed to permit easy configuration, monitoring, and troubleshooting of HART devices. The HART EDD for SITRANS Probe LU240 was written with SIMATIC PDM in mind and has been extensively tested with this software. For more information, see SIMATIC PDM (Page 209).

HART Electronic Device Description (EDD)

In order to configure a HART device, the configuration software requires the HART Electronic Device Description specific to the device. Download the HART EDD for SITRANS Probe LU240 from the product page of our website:

- Product page (www.siemens.com/sitransprobelu240)

Click "**Support > Software Downloads**". Older versions of the library will have to be updated in order to use all the features of SITRANS Probe LU240.

HART status

Information on HART status is outlined in an application guide **Working with HART networks**, which can be downloaded from the product page of our website:

- Product page (www.siemens.com/sitransprobelu240)

Under **More information**, click **Application guides**.

B.2 Configuring communication ports

Note

HART modem

It is recommended that only HCF registered modems be used.

Polling address

Polling address (04.01) (Page 144) (or poll ID) is a unique identifier for the device on a HART network.

Setting	0 to 63 (Set within range of 0 to 15 if HART 5 master used.)
Default	0

Prior to HART 6, the polling address was set to 0 for point to point operation. For HART multidrop mode, the device was set to any value other than 0 within the range. (Setting a non-zero address forced the device into fixed current mode.)

With HART 6 and above (version 7.6 supported by SITRANS Probe LU240), multidrop mode no longer depends on the polling address. However, it is recommended that a non-zero address be set to avoid confusion based on previous HART requirements.

To put SITRANS Probe LU240 into multidrop mode, disable Loop current mode (02-04.01) (Page 118). When Loop current mode is disabled, a low fixed current is used, allowing for multiple devices to be connected. (A custom fixed current value can be entered in Loop current value in multidrop mode (02-04.02) (Page 119).)

B.3 Communication troubleshooting

For more information, refer to Communication troubleshooting (Page 161).

Remote operation

C.1 SIMATIC PDM

SIMATIC PDM is a software package used to commission and maintain process devices. Please consult the operating instructions or online help for details on using SIMATIC PDM.

Check the support page of our website to make sure you have the latest version of SIMATIC PDM, the most recent Service Pack (SP) and the most recent hot fix (HF). Go to:

Software downloads (<http://www.siemens.com/processinstrumentation/downloads>)

In the Product tree, navigate to: "**Automation Technology > Process control systems > SIMATIC PCS 7 > System components > Plant Device Management > SIMATIC PDM**".

C.1.1 Initial setup

To ensure that SIMATIC PDM connects properly, complete the following two processes:

1. Deactivate buffers
2. Update the Electronic Device Description (EDD)

C.1.1.1 Deactivating buffers

This deactivation is required to align SIMATIC PDM with the HART modem when using a Windows® operating systems. Windows® is a registered trademark of the Microsoft Corporation.

Note

Connecting via serial port

- Deactivating buffers is only necessary when connecting via RS232 (COM1) as opposed to USB.
 - You will need administrative rights on your operating system to deactivate buffers.
 - SIMATIC PDM operates only in the Windows XP Professional version, not in the Home version.
-

1. From the computer desktop, click "**Start > Control Panel**" to begin configuration.
2. Click "**System and Security**", then select "**Device Manager**" under "**System**".
3. Open folder "**Ports**" and double click the COM Port used by the system to open the properties window.
4. Select the tab "**Port Settings**" tab and click the "**Advanced**" button.

5. If the "Use FIFO buffers" radio box is selected, click to deselect.

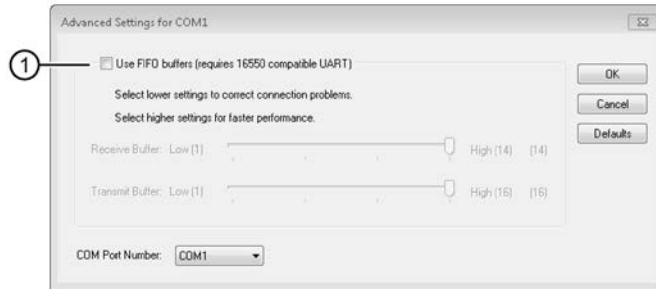

- ① Deselect **Use FIFO buffers** radio box

6. Click **OK** to close out. Close all screens and then restart the computer.

C.1.2 Updating Electronic Device Description (EDD)

You can locate the EDD in Device Catalog, under "**Sensors > Level > Echo > Siemens AG > SITRANS Probe LU240**". The EDD revision must match the Firmware revision in the device.

To install a new EDD:

1. Download the most current EDD from our website: Software downloads (<http://www.siemens.com/processinstrumentation/downloads>)
2. Save files to your computer and extract the zipped file to an easily accessed location.
3. Launch **SIMATIC PDM – Device Integration Manager**. From the File menu, click "Read device descriptions from compressed source...".
4. Browse to the unzipped EDD file, select and open it.
5. Use the "Integration" function to integrate the EDD into the device catalog. The EDD is now accessible via **SIMATIC Manager**.

C.1.2.1 Configuring a new device

Note

Configuring device via SIMATIC PDM

- Clicking "Cancel" button during an upload from device to SIMATIC PDM will result in *some* parameters being updated.
- **Application guides** for setting up HART devices with SIMATIC PDM are available. They can be found under **Support**. Go to: Product page (www.siemens.com/sitransprobelu240)

-
1. Check that you have the most recent EDD, and if necessary update it. See Updating Electronic Device Description (EDD) (Page 210).
 2. Launch **SIMATIC Manager** and create a new project for the device.

3. Open the menu "**Device > Reset > Factory reset**". Select "**Yes**" button and click "**OK**" to perform a reset to factory defaults.
4. After the reset is complete upload parameters to the PC/PG.
5. Configure the device via the quick start wizard. (See Wizard - Quick start... (Page 214).)

C.1.3 Changing parameter settings using SIMATIC PDM

SIMATIC PDM monitors the process values, alarms and status signals of the device. It allows you to display, compare, adjust, verify, and simulate process device data; also to set schedules for calibration and maintenance.

Parameters in SIMATIC PDM are identified by name and organized into function groups, similar to the structure of the local display (HMI).

Within SIMATIC PDM, parameters can be found in a structured view (which can be accessed when the device is offline), or in the PDM menus (when device is online): Device, View, Diagnostics.

See:

- Parameters via PDM structure view (Page 212)
- Parameters and methods via PDM menus (Page 212)

Note

- Clicking button "Cancel" during an upload from device to SIMATIC PDM will result in *some* parameters being updated.
 - While the device is in **Edit view** the output remains active and continues to respond to changes in the device.
-

1. Launch SIMATIC PDM, connect to device, and upload data from device.
2. Adjust parameter values in the parameter value field then press "Enter" key. The status fields read "Changed".
3. Open the Device menu, click "Download to device...". When complete, use "**File > Save**" to save settings offline. The status fields are cleared.

C.1.4 Parameters via PDM structure view

Many parameters accessible via SIMATIC PDM **Structure view** are also accessible via local operation. Others are accessible only via PDM.

Note

Parameters accessible via HMI vs PDM

- For details on parameters accessible via HMI see Parameter assignment - Local (Page 109).
- For details on parameters accessible via PDM only see Parameter assignment - Remote (Page 147).

If a parameter is not available in PDM **Structure view**, refer to the PDM menus: Parameters and methods via PDM menus (Page 212).

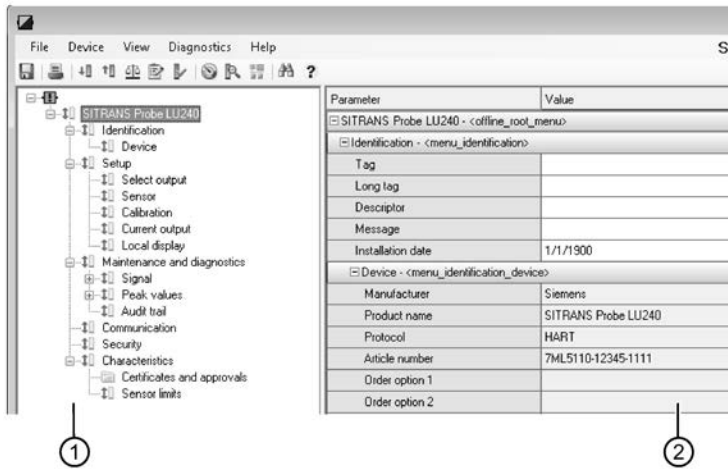

- ① Structure view (offline table)
- ② Value fields

C.1.5 Parameters and methods via PDM menus

Click on **Device**, **View**, or **Diagnostics** to open the associated PDM menu.

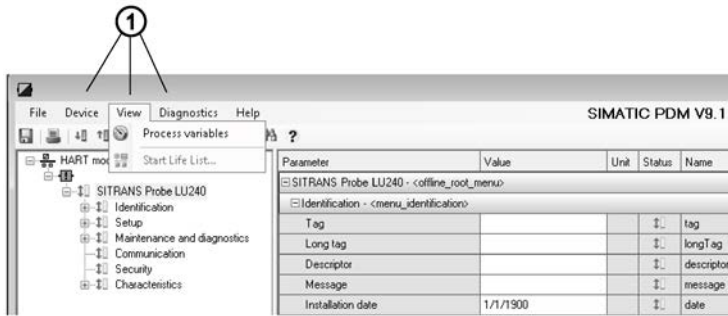

- ① PDM menus

PDM menus

Device	View	Diagnostics
Download to device Upload to PC/PG	Process values (Page 237)	Update diagnostics
Assign address and Tag... Value comparison... Object properties... Calibration log... Change Log...	Start Life List...	Diagnostics (Page 238) Device status (Page 238)
Check configuration... Templates		Parameter change log (Page 238) Diagnostic log (Page 238) Trend log (Page 238)
Set Address... HART communication Squawk		
Wizard - Quick start... (Page 214) Wizard - Auto false echo suppression (Page 214)		
Sensor offset wizard (Page 214) Auto sound velocity wizard (Page 215)		
DAC trim (Page 215)		
Simulation (Page 216) Loop test (Page 218)		
Scheduled maintenance (Page 218) Limit monitoring and event counter (Page 224) Trend log settings (Page 228) Echo profile utilities (Page 231)		
Security (Page 236)		
Reset (Page 236) Reset peak values (Page 237) Reset configuration flag (Page 237)		
Device restart (Page 237)		

C.1.5.1 Device menu

Wizard - Quick start...

Provides step-by-step procedure to set up common applications easily.

A quick commissioning wizard is available in SIMATIC PDM.

Launch PDM, open the menu "**Device > Wizard - Quick start...**", and follow the steps in the wizard.

Note

Update of process value on display when commissioning wizard run via EDD

Process values shown in **measurement view** on local display will not automatically update to reflect a change made remotely via "Wizard - Quick start...".

- To have device process values update when configured remotely, use local buttons to take device in and out of **measurement view** (i.e. go to **parameter view** then back to **measurement view**).
-

Wizard - Auto false echo suppression

Used to prevent false echo detection over a specified range.

The Auto false echo suppression (AFES) wizard is available in SIMATIC PDM.

Launch PDM, open the menu "**Device > Wizard - Auto false echo suppression**".

Enter the auto false echo suppression range, then click "Apply" to run the wizard.

Sensor offset wizard

Used to calculate sensor offset, based on an actual measurement, to change the distance value.

Note

Wizard operation requires 22.5 mA

Device output will read 22.5 mA during wizard operation. When wizard completes, device output will return to normal behavior.

Via SIMATIC PDM, go to menu "**Device > Sensor offset wizard**".

The Sensor offset wizard can be found in PDM, in the menu "**Device > Sensor offset wizard**".

Enter value for the parameter "Sensor offset", then click "Apply" to run the wizard.

Auto sound velocity wizard

Used to adjust the speed of sound, based on an actual measurement, to change the distance value.

Note

Wizard operation requires 22.5 mA

Device output will read 22.5 mA during wizard operation. When wizard completes, device output will return to normal behavior.

Via SIMATIC PDM, go to menu "**Device > Auto sound velocity wizard**".

Conditions for use of this feature:

- The acoustic beam atmosphere is other than air
- The acoustic temperature is unknown
- The reading accuracy is acceptable at higher material levels only

For best results, calibrate with the level at a known value near low calibration point.

Using Auto sound velocity

Start with a steady distance at a known high distance value (high distance value equates to a low level value).

1. Review the distance measurement via local display for approximately 30 seconds to verify repeatability.
2. Measure the actual distance (for example, with a tape measure).
3. Enter the actual distance, defined in parameter "Units".

Repeat this procedure if the atmosphere type, concentration, or temperature conditions are different from when the last sound velocity calibration was performed.

The Auto sound velocity wizard can be found in PDM, in the menu "**Device > Auto sound velocity wizard**".

Enter the actual distance measured, then click "Apply" to run the wizard.

DAC trim

Used to calibrate the 4 mA and 20 mA end points of the analog output with an external reference (e.g. current measurement device).

Open menu "**Device > DAC trim**".

Connect the external device when prompted. Enter a new mA value and click button "Ok", or "Cancel" to exit without saving.

Simulation

Both process values and diagnostics can be simulated in SIMATIC PDM. For more details, see Simulation (Page 103).

Process values

Simulation of a process value is an iterative process whereby parameters are adjusted and corresponding results are displayed.

Parameter assignment

Simulation mode

Displays status of simulation.

Setting	Disabled
	Enabled
	Ramp
Default	Disabled

Set to "Enabled" to hold the simulation at a specific value. Set to "Ramp" to have the simulation continuously sweep through the measurement range.

Simulation value

Sets starting value for ramp or fixed simulation.

Setting	No limits
Default	Not applicable

PV status

Sets status of the PV to simulate.

Setting	Good
	Bad
	Uncertain
Default	Good

Ramp end

Sets end value for ramp simulation.

Setting	No limits
Default	Not applicable

Ramp steps

Sets number of stair steps between ramp start (parameter "Simulation value") and end of ramp simulation.

Setting	0 to 65535
Default	10

Ramp duration

Sets total time from ramp start (parameter "Simulation value") to end of ramp simulation.

Setting	0 to 65535
Default	5

Diagnostics

Diagnostics can be simulated via SIMATIC PDM.

For more information, see Simulation (Page 103).

Parameter assignment

Diagnostics

Sets diagnostic from select list to simulate.

Setting	All available Device and HART status codes, and all process alarms and warnings available to "Limit monitoring" function.
Default	Not applicable

Action

Enables/disables simulation for a specific diagnostic value.

Setting	On
	Off
Default	Not applicable

Loop test

Provides step-by-step procedure to simulate the loop current.

A loop test can be initiated via local operation (with any errors reported through diagnostic icons on the local display), or remotely, using an engineering system such as SIMATIC PDM.

Note

Simulated current output

The simulated current output value influences output to the control system.

A simulated value can be set to test the functioning of the mA connections during commissioning or maintenance of the device.

Setting	4.0 mA
	20.0 mA
	Other (set any mA value between 3.55 and 22.8)
	End
Default	4.0 mA

Select a preset mA value, or enter a custom value (under option "Other") to run the wizard. Select option "End" to stop the loop test.

For more information, see mA control (Page 77).

Scheduled maintenance

Three sets of parameters allow you to monitor the Device lifetimes and set up Service and Calibration schedules, based on operating hours instead of a calendar-based schedule. See Device (Page 219), Service (Page 220), and Calibration (Page 222).

The Scheduled maintenance feature is available through HART communications. This information can be integrated into an Asset Management system. For optimal use, we recommend that you use SIMATIC PCS7 Asset Management Software in conjunction with SIMATIC PDM.

Note

Maintenance reminders

- Any active maintenance reminders can be seen in "**Diagnostics > Device status**".
 - Click button **Reset elapsed time** to reset the elapsed time to zero, and clear any active diagnostic alarms.
-

Note

Factory reset

Performing a reset to factory defaults will reset all Scheduled maintenance parameters to their factory defaults.

Device

The device tracks itself based on operating time and monitors its predicted life expectancy. Operating time can be modified, Elapsed time can be reset, and schedules can be set up for maintenance reminders.

Via PDM: Go to menu "**Device > Scheduled maintenance**", and select the tab "Device maintenance".

Parameter assignment

Time units

Sets units for maintenance parameters.

Setting	Years
	Days
	Hours
Default	Years

If time units are changed after device has been in operation, values for parameters "Operating time", "Maintenance required", and "Maintenance demanded" must also be adjusted to reflect the new time units.

Operating time

Shows Operating time of device since last power up.

Can be modified after performing a service. If device Operating time is modified, Elapsed time and Remaining time will automatically recalculate.

Setting	No limits
Default	10.000 years

Elapsed time

Displays elapsed time since timer was reset. Parameter "Monitoring" must be enabled.

If value for parameter "Elapsed time" reaches limits set in parameters "Maintenance demanded" or "Maintenance required", a diagnostic message is generated.

Remaining time

Displays remaining hours of operation.

Monitoring

Sets operation mode for timer function.

The setting "Off" stops timer. When set to "Only timer on", elapsed time runs, but when thresholds are reached no diagnostic message is generated.

Setting	Off
	Only timer on
	Maintenance required
	Maintenance demanded
	Maintenance required and demanded
Default	Off

1. First, set values in **Maintenance required** and/or **Maintenance demanded**.
2. Set **Monitoring** to the desired option.

Maintenance required

Sets Maintenance required reminder if Elapsed time is equal to or greater than this value.

Setting	No limits
Default	9.836 years (Default value for parameter "Operating time" less 8 weeks)

1. Modify values as required.
2. Set **Monitoring** to the desired option.

Maintenance demanded

Sets Maintenance demanded reminder if Elapsed time is equal to or greater than this value.

Setting	No limits
Default	9.981 years (Default value for parameter "Operating time" less 1 week)

1. Modify values as required.
2. Set **Monitoring** to the desired option.

Service

The device tracks service intervals based on operating hours and monitors the predicted time until the next service. Service interval can be modified, Elapsed time can be reset, and schedules can be set up for maintenance reminders.

Via PDM: Go to menu "**Device > Scheduled maintenance**", and select the tab "**Service**".

Parameter assignment

Time units

Sets units for maintenance parameters.

Setting	Years
	Days
	Hours
Default	Years

If time units are changed after device has been in operation, values for parameters "Service interval", "Maintenance required", and "Maintenance demanded" must also be adjusted to reflect the new time units.

Service interval

Sets time between device inspections.

Can be modified after performing a service. If Service interval is modified, Elapsed time and Remaining time will automatically recalculate.

Setting	No limits
Default	1.000 year

Elapsed time

Displays elapsed time since timer was reset. Parameter "Monitoring" must be enabled.

If value for parameter "Elapsed time" reaches limits set in parameters "Maintenance demanded" or "Maintenance required", a diagnostic message is generated.

Remaining time

Displays remaining hours of operation.

Monitoring

Sets operation mode for timer function.

The setting "Off" stops timer. When set to "Only timer on", elapsed time runs, but when thresholds are reached no diagnostic message is generated.

Setting	Off
	Only timer on
	Maintenance required
	Maintenance demanded
	Maintenance required and demanded
Default	Off

1. First, set values in **Maintenance required** and/or **Maintenance demanded**.
2. Set **Monitoring** to the desired option.

Maintenance required

Sets Maintenance required reminder if Elapsed time is equal to or greater than this value.

Setting	No limits
Default	0.836 years (Default value for parameter "Service interval" less 8 weeks)

1. Modify values as required.
2. Set **Monitoring** to the desired option.

Maintenance demanded

Sets Maintenance demanded reminder if Elapsed time is equal to or greater than this value.

Setting	No limits
Default	0.981 years (Default value for parameter "Service interval" less 1 week)

1. Modify values as required.
2. Set **Monitoring** to the desired option.

Calibration

The device tracks calibration intervals based on operating hours and monitors the predicted time until the next calibration. Calibration interval can be modified, Elapsed time can be reset, and schedules can be set up for maintenance reminders.

Via PDM: Go to menu "**Device > Scheduled maintenance**", and select the "Calibration" tab.

Parameter assignment

Time units

Sets units for maintenance parameters.

Setting	Years
	Days
	Hours
Default	Years

If time units are changed after device has been in operation, values for parameters "Calibration interval", "Maintenance required", and "Maintenance demanded" must also be adjusted to reflect the new time units.

Calibration interval

Sets time between device calibrations.

Can be modified after performing a calibration. If "Calibration interval" is modified, "Elapsed time" and "Remaining time" will automatically recalculate.

Setting	No limits
Default	1.000 year

Elapsed time

Displays elapsed time since timer was reset. Parameter "Monitoring" must be enabled.

If value for parameter "Elapsed time" reaches limits set in parameters "Maintenance demanded" or "Maintenance required", a diagnostic message is generated.

Remaining time

Displays remaining hours of operation.

Monitoring

Sets operation mode for timer function.

The setting "Off" stops timer. When set to "Only timer on", elapsed time runs, but when thresholds are reached no diagnostic message is generated.

Setting	Off
	Only timer on
	Maintenance required
	Maintenance demanded
	Maintenance required and demanded
Default	Off

1. First, set values in **Maintenance required** and/or **Maintenance demanded**.
2. Set **Monitoring** to the desired option.

Maintenance required

Sets Maintenance required reminder if Elapsed time is equal to or greater than this value.

Setting	No limits
Default	0.836 years (Default value for parameter "Calibration interval" less 8 weeks)

1. Modify values as required.
2. Set **Monitoring** to the desired option.

Maintenance demanded

Sets Maintenance demanded reminder if Elapsed time is equal to or greater than this value.

Setting	No limits
Default	0.981 years (Default value for parameter "Calibration interval" less 1 week)

1. Modify values as required.
2. Set **Monitoring** to the desired option.

Limit monitoring and event counter

Used to monitor select process values, count associated events based on configured limits, and trigger, acknowledge, and reset process alarms and warnings.

Configure variables for monitoring

Configure one process value per Limit monitoring tab. Select the process value to monitor from the Monitored value drop-down list. Enter Upper limit, Lower limit, and Hysteresis values that will trigger an event.

Limits

Limits are assigned to each process value (Monitored value). The following limit parameters are available:

- Upper limit
- Lower limit
- Hysteresis

Hysteresis

Hysteresis functions as follows:

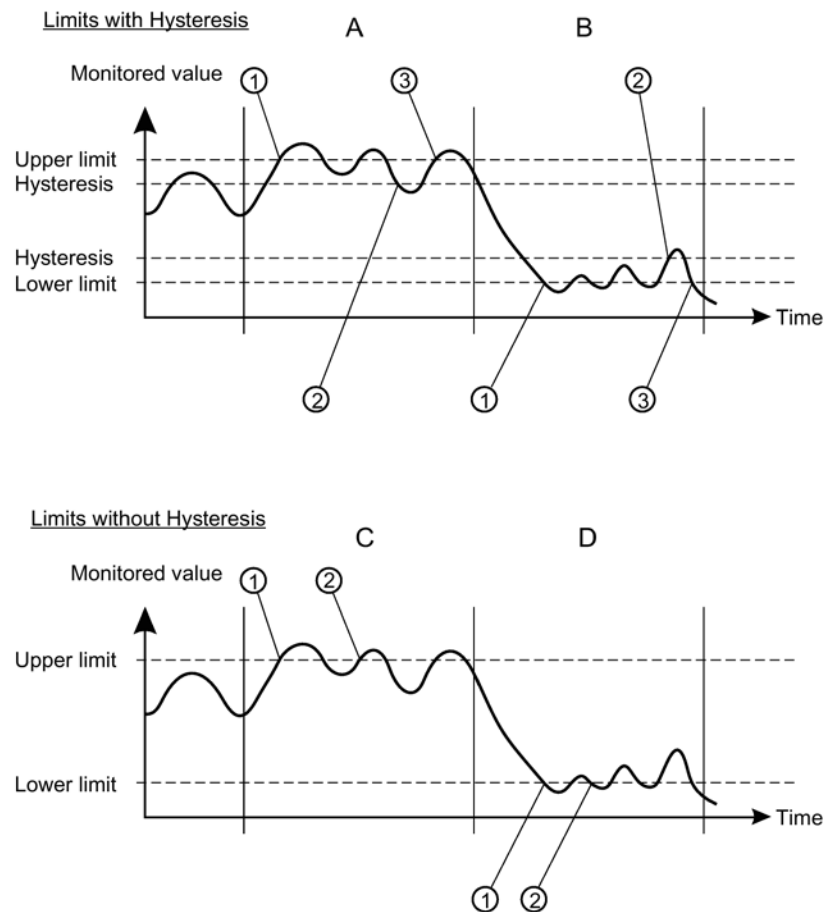

A: Upper limit with Hysteresis

An Overrun event is counted when the process value rises above the Upper limit (1). The next Overrun event is counted when the process value first falls below the Upper limit minus Hysteresis (2), then rises above the Upper limit (3).
With Hysteresis enabled (non-zero value entered), two events will be counted within the timeframe depicted by 'A'.

B: Lower limit with Hysteresis

An Underrun event is counted when the process value falls below the Lower limit (1). The next Underrun event is counted when the process value first rises above the Lower limit plus Hysteresis (2), then falls below the Lower limit (3).

C: Lower limit without Hysteresis

An Underrun event is counted when the process value falls below the Lower limit (1). The next Underrun event is counted when the process value rises above the Lower limit (2) by any amount (as Hysteresis is set to zero), then falls below the Lower limit (2).

With Hysteresis disabled (zero value entered), three events will be counted within the timeframe depicted by 'C'.

D: Upper limit without Hysteresis

An Overrun event is counted when the process value rises above the Upper limit (1). The next Overrun event is counted when the process value falls below the Upper limit (2) by any amount (as Hysteresis is set to zero), then rises above the Upper limit (2).

Events and actions

When the process value exceeds the Upper limit (Overrun) or falls below the Lower limit (Underrun), adjusting for any Hysteresis, an event is counted.

Set a Threshold value for the number of Underrun and Overrun events that must occur for the selected Action to trigger. (Setting either threshold to a non-zero value will automatically set Limit monitoring to Enabled. Conversely, when Limit monitoring is set to Disabled, threshold values will be reset to zero.)

The Action can be disabled, or set to trigger process alarms, or warnings such as Maintenance demanded and Maintenance required. Process alarms and warnings are displayed on the Device status dialogue in the engineering system, and on the device display as status symbols.

Any alarms or warnings triggered prior to setting Action to Disabled will remain present until the event counter is reset. Disabling the Action means no new alarms or warnings will be triggered for the set limits, although the counter remains in operation.

Actions and Fail-safe mode

Process alarms can trigger fail-safe behavior on the signal output, whereas process warnings are only used as information, available through local operation and in the engineering system. Process values will bring the signal output to fail-safe mode if:

- Specific fault (designed to put mA output into fail-safe mode) occurs. (See Fault codes and corrective actions (Page 165).)
- Maintenance alarm occurs on a process value selected on the output.

Enable monitoring

Once monitored variable is configured, ensure Limit monitoring is set to Enabled, and Transfer to device. Repeat steps on separate limit monitoring tab to monitor another process value.

View and reset event counter

If process alarms or warnings are triggered during device operation, return to this dialogue to Reset and acknowledge. The event counter is reset, and process alarms and warnings are acknowledged and cleared.

Parameter assignment

Limit monitoring

Used to monitor select process values, count associated events based on configured limits, and trigger, acknowledge, and reset process alarms and warnings.

Note

Number of monitored values

In SITRANS LU240, up to three values can individually monitored.

Setting	Enabled
	Disabled
Default	Disabled

Monitored value

Sets process value to monitor.

Setting	Distance
	Space
	Level
	Volume
	Volume flow
	Custom
	Sensor temperature
Default	Limit monitoring 1 = Primary variable
	Limit monitoring 2 = Distance
	Limit monitoring 3 = Sensor temperature

Upper limit

Sets Upper limit for a select process value being monitored.

Setting	-999999.0 to 999999.0
Default	999999.0

Lower limit

Sets Lower limit for a select process value being monitored.

Setting	-999999.0 to 999999.0
Default	-999999.0

Hysteresis

Sets difference between Upper Limit and Lower Limit for a select process value being monitored, that must occur before an Event is counted.

The Action state (enabled/disabled) lags behind the measurement. If the measurement is larger than the limit, the configured Action is raised. The Action is only cleared if the measurement falls below the limit minus the hysteresis.

Setting	-999999.0 to 999999.0
Default	Limit monitoring 1 = 0.25 m
	Limit monitoring 2 = 0.25 m
	Limit monitoring 3 = 5 °C

Action

Sets the diagnostic state reported when threshold is reached. For error (NE107) or maintenance alarm (PCS7), fault current is generated.

Setting	Disabled
	Process alarms
	Maintenance required
	Maintenance alarm
Default	Maintenance alarm

Events

Displays number of times the monitored value reaches the upper limit and/or the lower limit (overrun and/or underrun events).

Threshold

Sets number of times the value passes the threshold before the diagnostic message configured in parameter "Action" is generated.

Setting	0 to 65535
Default	3

Trend log settings

The trend log can be configured in SIMATIC PDM, under menu "**Device > Trend log settings**".

1. Enable logging by setting a number of values to log in parameter "Number of logging values".
2. Enter the number of points to log in parameter "Number of logged points".
3. Set the interval in seconds between log entries in parameter "Logging interval".
4. Define the buffer behavior when log is full in parameter "Logging behavior".

5. Set specific process value to log in parameters "Logging value 1", "Logging value 2", and "Logging value 3".
 6. Click "Transfer" button to write log settings to device.
- View the trend log under menu "**Diagnostics > Trend log**".

Parameter assignment

Number of logging values

Sets number of process values to log.

Setting	Disabled
	1
	2
	3
Default	Disabled

Number of logged points

Sets number of data points to capture.

Setting	10 to 2010
Default	300

A minimum of 10 points must be logged. The maximum number of points that can be logged is based on the number of inputs (parameters "Logging value 1", "Logging value 2", "Logging value 3"), i.e. 2010 points can be logged for one input, 1005 points for two inputs, and 670 points for three inputs.

Logging interval

Sets interval in seconds between log entries.

Setting	10 to 600
Default	60

Logging behavior

Defines behavior when log is full.

Setting	Overwrite oldest
	Fill and stop
Default	Overwrite oldest

Logging value 1

Sets value to log.

Setting	Distance
	Space
	Level
	Volume
	Volume flow
	Custom
	Sensor temperature
Default	Distance

Logging value 2

Sets value to log.

Setting	Distance
	Space
	Level
	Volume
	Volume flow
	Custom
	Sensor temperature
Default	Distance

Logging value 3

Sets value to log.

Setting	Distance
	Space
	Level
	Volume
	Volume flow
	Custom
	Sensor temperature
Default	Distance

Echo profile utilities

Open the menu "**Device > Echo profile utilities**" and click on the appropriate tab for easy access to:

- Echo profile (Page 231)
- View saved echo profiles (Page 232)
- Custom TVT breakpoints (Page 232)
- Auto false echo suppression (Page 235)
- Echo profile setup (Page 235)

Echo profile

1. In the **Echo profile utilities** window, click the "Echo profile" tab.
2. Click "Measure" to update the profile. (The Initial profile graph is blank upon entry to dialog.)
3. Use the **Detailed** resolution view of the echo profile for troubleshooting. For faster and more coarse views, the **Standard** resolution may be used.
4. Edit the profile:
 - To see the X scale and data scale values, double click on each axis.
 - To zoom in to a section of the profile, left-click and drag a marquee around it. Right click inside the window to zoom out.
 - To expand or compress the x and/or y axes
 - Left-click the axis and drag in either direction to reposition the low end of the scale.
 - Right-click the axis and drag in either direction to reposition the high end of the scale.
5. Click the "Save" button and in the new window, enter a name, and click "Yes".
6. Click "OK" button to exit. (Do not click the "x" button to close the **Echo profile utilities** window, the profile will not be saved.)

Parameter assignment

Signal parameters

For details on respective signal parameters, see Parameter assignment - Local (Page 109).

Under the "Echo profile" tab, "Echo confidence" and "Signal strength" will display the corresponding parameter values, dependent on whether a short shot or long shot transmit pulse is used. (Refer to parameters: "Short shot confidence" / "Confidence", "Short shot echo signal strength" / "Echo signal strength".)

Logging interval

Sets interval in minutes between echo profile log entries.

Setting	0 to 60
Default	10 minutes

Number of profiles

Sets number of echo profiles to store.

Setting	1 to 60
Default	5

View saved echo profiles

Echo profile storage

You can store up to 60 profiles at a selected interval (maximum 60 minutes). Within the "Echo profile" tab, in the "Echo profile time based storage" window:

- Enter the desired interval between stored profiles in parameter "Logging interval".
- Enter the maximum number of profiles to be stored (maximum 60) in parameter "Number of profiles".
- Click the "Start" button. A message appears warning of the time delay and warning that all previous saved profiles will be overwritten. Click the "OK" button to proceed. The new profiles will be saved with their date and time.

Within menu "Echo profile utilities", click the tab "View saved echo profiles" to view the stored profiles.

Custom TVT breakpoints

Note

Double click on each axis to see the X scale and data scale values. Right-click or left-click on the axis and drag to reposition the scale.

This feature allows you to manually adjust the TVT to avoid false echoes caused by obstructions. For an explanation see Auto false echo suppression (Page 235).

Open the menu "**Device > Echo profile utilities**" and click the tab "Custom TVT breakpoints".

Before TVT adjusted

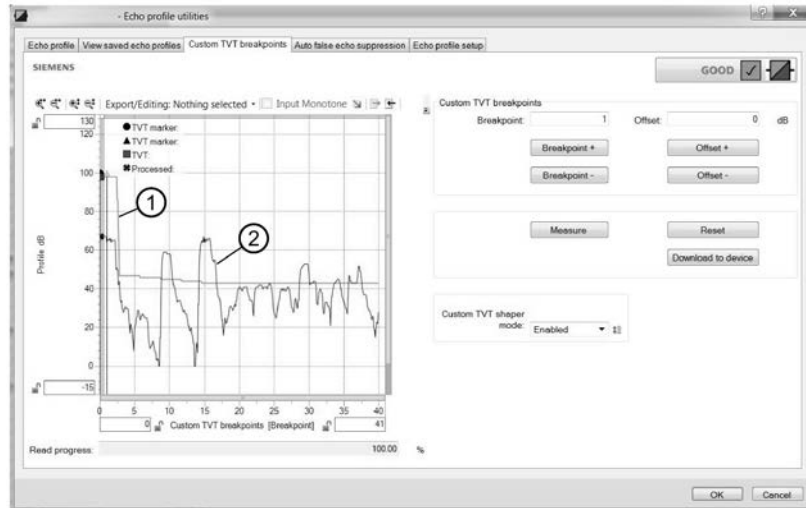

- ① TVT
- ② Echo profile

Note

Profile display

If a communication error exists, the profile will not display.

- Initial profile graph is blank upon entry to dialog. Click the "Measure" button to view and upload the current TVT from device.
- Change the position of the cursor on the TVT using the "TVT Point +" and "TVT Point -" buttons: raise and lower the TVT using the "Offset +" and "Offset -" buttons.
- Alternatively, enter values for "TVT Point" and "Offset" directly into the dialog boxes.
- Click button "Download to device".

After TVT adjusted

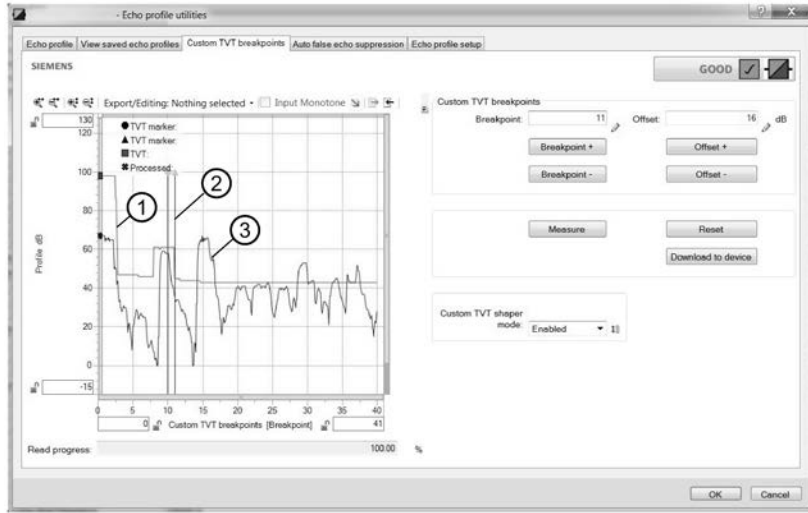

- ① TVT
- ② Cursor
- ③ Echo profile

Note

Download to device

If steps are repeated (measurement taken a second time) without first downloading shaping adjustments to the device, initial shaping will be lost.

Parameter assignment

Custom TVT shaper mode

Sets operation mode of custom TVT shaper.

Setting	Enabled
	Disabled
Default	Disabled

Breakpoint 1 to Breakpoint 40

Sets TVT offset for breakpoint on TVT. Shaping points can be raised (positive number) or lowered (negative number).

Setting	Offset 1 to 50 dB
Default	0 dB

Auto false echo suppression

For detailed information about auto false echo suppression see Auto false echo suppression and Custom TVT (Page 190).

For respective parameter details, see Parameter assignment - Local (Page 109).

To use this feature in SIMATIC PDM:

1. Ensure the material level is below all known obstructions.
2. Determine the auto false echo suppression range by measuring the actual distance from the sensor reference point to the material surface using a rope or tape measure. Subtract 0.5 m (20") from this distance, and use the resulting value.
3. Open the menu "**Device > Echo profile utilities**" and click the tab "Auto false echo suppression".
4. Set parameter "Auto false echo suppression" to "Enabled".
5. For parameter "Auto false echo suppression range", enter the value determined above.
6. Click button "Wizard - Auto false echo suppression" to learn the TVT. The wizard dialogue will open. Click the button "Apply".
Once the wizard completes successfully, parameter "Auto false echo suppression" is set to "Enabled" and the learned TVT will be used.
7. Click button "Download to device". Click button "OK" to exit.



Echo profile setup

Provides quick access to allow configuration of echo processing related parameters.

Open the menu "**Device > Echo profile utilities**" and click tab "Echo profile setup".

For respective parameter details, see Parameter assignment - Local (Page 109).

Security

From the menu "**Device > Security**" in PDM, you can enable or disable the user PIN used to lock/unlock the device, change the existing user PIN, or set a new user PIN if the existing one is forgotten.

Enable/Disable user PIN

The button "Enable user PIN"/"Disable user PIN" toggles between the two options, based on the current device setting. The device is shipped unlocked (user PIN disabled).

- Click button "Enable user PIN" to lock the device. Message appears that the device is now write protected.
- Click button "Disable user PIN" to unlock the device. If the default user PIN (factory setting) has not been changed (using "Change user PIN" wizard), enter the default PIN (2457) to unlock the device.

Change user PIN

Button appears when user PIN is disabled.

Click button "Change user PIN".

- Enter the existing user PIN.
- Enter a new user PIN (0 to 65535), and repeat entry of new user PIN.

Click button "OK". Message appears that new user PIN is set.

Reset forgotten user PIN

Button appears when user PIN is enabled.

Click button "PIN recovery" if you have forgotten your user PIN.

- A recovery ID and serial number will display. Make note of these entries and contact Siemens Technical Support.
- You will be supplied with a PIN unlock key (PUK).
- Enter the PUK on this dialogue

Click button "OK". Message appears that new user PIN is set.

Reset

Open menu "**Device > Reset**" to access various restore/reset options:

- Restore ordered configuration - restores device to customer-ordered default settings
- Restore to factory DAC calibration - restores DAC trim (digital-to-analog converter trim) to factory default settings
- Factory reset - resets device to factory default settings.

Click button "Yes" to continue with restore/reset, or click button "Abort" to cancel.

After performing a "Factory reset", a complete re-programming is required.

A "Restore to factory DAC calibration" is available only over remote operation.

Reset peak values

Resets all recorded Peak values.

Open menu **Device > Reset peak values** to reset recorded peak values to zero. Choose from various reset options:

- Primary variable - reset minimum and maximum values for PV
- Distance - reset minimum and maximum values for distance
- Sensor temperature - reset minimum and maximum values for sensor temperature
- Peak values - reset minimum and maximum values for PV, distance, and sensor temperature

Click button "Ok" to continue with reset, or click button "Cancel" to exit without a reset.

Reset configuration flag

Open menu "**Device > Reset configuration flag**" to reset the configuration flag to zero.

Device restart

Open menu "**Device > Device restart**" to restart device without disconnecting power.

Simulation will be terminated. Stored configurations are not reset.

C.1.5.2 View menu

Process values

Open the menu "**View > Process values**" to view and compare outputs in real time, and view trend lines.

- Click the "Overview" tab to see measurements (distance, level, loop current), device status, and data quality.
- Click the "Dashboard" to display respective PV and SV measurements, range, loop current, and sensor temperature. (PV is set in parameter "PV selection". SV is set in parameter "SV selection".)
- Click the "Trend" tab to view trend lines. Four trend lines can be monitored (distinguished by color in PDM).

Trend

Displays Trend line.

C.1.5.3 Diagnostics menu

Diagnostics

Open the menu "**Diagnostics > Diagnostics**" to view communication status and device status.
Click the "Update diagnostics" button to update the diagnostic information and refresh the related status symbols.

Device status

Open the menu "**Diagnostics > Device status**" to view standard and device-specific status.
Device "Operating time" is also shown.

Parameter change log

Open the menu "**Diagnostics > Parameter change log**" to view log of parameter changes made to device.

Up to 100 entries can be logged with the oldest entry being overwritten when log becomes full.

Click the "Read" button to update the log, then select the number of entries to read (10 to 100).

Diagnostic log

Open the menu "**Diagnostics > Diagnostic log**" to view log of diagnostics events and when they occurred.

Up to 250 entries can be logged with the oldest entry being overwritten when log becomes full.

Click the "Read" button to update the log.

Trend log

Open the menu "**Diagnostics > Trend log**" to view trends. (The trend log must first be configured and enabled. See Trend log settings (Page 228).)

The PV and SV (set in parameter "PV selection" and parameter "SV selection") are logged at a specified interval, and the trend log displays up to 670 data points since last device power up.

The number of points already collected, and the start time are shown. (Click the "Reset" button to reset the log in the device.)

Click the "Read" button to update the log. A dialogue appears on which you can set the number of points to read, the point density, and the start time to read. (An example setting for point density: if point density is set to 2, every second value will show.)

When settings are complete, click the "Transfer" button.

Trend lines can be viewed in menu "**View > Process values**", on the "Trend" tab.

C.2 AMS device manager

AMS Device Manager is a software package used to commission and maintain SITRANS Probe LU240 and other process devices. AMS Device Manager monitors the process values, alarms and status signals of the device. It allows you to display, compare, adjust, verify, and simulate process device data. Please consult the operating instructions or online help for details on using AMS Device Manager. (You can find more information at: Emerson (<http://www.emersonprocess.com/AMS/>))

AMS Device Manager features a Quick start wizard to easily configure the SITRANS Probe LU240. Other features include Echo profile viewing, Custom TVT setup, Process values monitoring, and Security.

Parameters organized into three main function groups allow you to configure and monitor the device:

- Configure/Setup
- Device diagnostics (read only)
- Process values (read only)

The menu structure for AMS Device Manager is almost identical to that for SIMATIC PDM.

Startup and configuration

To start up the SITRANS ProbeLU240 using AMS Device Manager, you must first install the EDD (see below). You can then configure the device using the Quick start wizard in AMS.

Electronic device description (EDD)

SITRANS Probe LU240 requires the EDD for AMS Device Manager version 13.5.

You can locate the EDD in Device Catalog, under "**Sensors > Level > Echo > Siemens AG > SITRANS Probe LU240**". Check the product page of our website:

Product page (www.siemens.com/sitransprobelu240)

Look under "**Support > Software Downloads**", to make sure you have the latest version of the EDD for AMS Device Manager.

Configuring a new device

1. Check that you have the most recent EDD, and if necessary download it from the product page listed above.
2. Save the files to your computer, and extract the zipped file to an easily accessed location.
3. Launch "**AMS Device Manager – Add Device Type**", browse to the unzipped EDD file, select and open it.
4. Launch **AMS Device Manager**.
(Application guides for setting up HART devices with AMS Device Manager can be downloaded from product page of our website.)
5. In **Device Connection View**, right-click on the device icon and select **Scan Device** to upload parameters from the device.

6. Double click the device icon to open the startup screen. The startup screen shows device identification details, and a navigation window on the left-hand side of the screen.
7. Configure the device using the Quick start wizard.

C.3 Field Communicator (FC) 375/475

The FC375/FC475 HART Communicator is a handheld communication device that is easy to use, and provides universal support for other HART devices, such as SITRANS Probe LU240.

The menu structure for FC375/FC475 is almost identical to that for AMS Device Manager.

Startup and configuration

In order to configure this HART device, just as with AMS, the configuration software requires the HART Electronic Device Description (EDD) for the instrument. Once the EDD is installed, you can configure the device using the Quick start wizard within FC375/475.

Electronic device description (EDD)

You can locate the EDD in Device Catalog, under "**Sensors > Level > Echo > Siemens AG > SITRANS Probe LU240**". Check the product page of our website:

Product page (www.siemens.com/sitransprobelu240)

Look under "**Support > Software Downloads**", to make sure you have the latest version of the EDD for FC375/FC475.

Configuring a new device

1. Check that you have the most recent EDD, and if necessary download it from the product page listed above.
2. Save the files to your computer, and extract the zipped file to an easily accessed location.
3. To install the EDD, run Emerson's *Field Communicator Easy Upgrade Utility*.
4. Configure the device using the Quick start wizard.

C.4 FDT (Field Device Tool)

FDT is a standard used in several software packages designed to commission and maintain field devices such as SITRANS Probe LU240. Two commercially available FDTs are PACTware and Fieldcare.

FDT is very similar to PDM:

- To configure a field device via FDT, you need the DTM (Device Type Manager) for the device.
- To configure a field device via SIMATIC PDM, you need the EDD (Electronic Data Description) for the device.

Setup and configuration

To start up the SITRANS Probe LU240 using an FDT, you must first install the DTM (see below). You can then configure the device using the parameters available with the FDT.

Device Type Manager (DTM)

A DTM is a type of software that *plugs into* FDT. It contains the same information as an EDD but an EDD is independent of the operating system.

SITRANS DTM version 3.1

- SITRANS DTM is an EDDL interpreter developed by Siemens to interpret the EDD for that device.
- To use SITRANS DTM to connect to a device, you must first install SITRANS DTM on your system and then install the device EDD written for SITRANS DTM.
- You can download SITRANS DTM from our website. Go to website (<http://www.siemens.com/sitransdtm>) and click "**Support > Software downloads**".

Electronic Device Description (EDD)

The SITRANS Probe LU240 HART EDD for SITRANS DTM can be downloaded from the product page of our website. Go to Product page (www.siemens.com/sitransprobelu240) and click "**Support > Software downloads**".

Configuring a new device

The full process to configure a field device via FDT is outlined in an application guide for SITRANS DTM, which can be downloaded from the product page of our website. Go to Product page (www.siemens.com/sitransprobelu240) and click "**Support > Application guides**".

Certificates and support

D.1 Certificates

You can find certificates on the Internet at Certificates (<http://www.siemens.com/processinstrumentation/certificates>) or on an included DVD.

D.2 Technical Support

Technical Support

If this documentation does not provide complete answers to any technical questions you may have, contact Technical Support at:

- Support request (<http://www.siemens.com/automation/support-request>)
- More information about our Technical Support is available at Technical Support (<http://www.siemens.com/automation/csi/service>)

Internet Service & Support

In addition to our documentation, Siemens provides a comprehensive support solution at:

- Services & Support (<http://www.siemens.com/automation/service&support>)

Personal contact

If you have additional questions about the device, please contact your Siemens personal contact at:

- Partner (<http://www.automation.siemens.com/partner>)

To find the personal contact for your product, go to "All Products and Branches" and select "Products & Services > Industrial Automation > Process Instrumentation".

Documentation

You can find documentation on various products and systems at:

- Instructions and manuals (<http://www.siemens.com/processinstrumentation/documentation>)

D.3 QR code label

A QR code label can be found on the device. With the use of a smart phone, the QR code provides a direct link to a website with information specific to the device, such as manuals, FAQs, certificates, etc.

Example QR code

The QR code that follows is an example only. The QR code found on your device is unique to that device and serial number.



HMI menu structure

Note

Three-level menu structure

For the purpose of documenting, items in the following menu structure are not exactly as they appear on the device.

- Parameter IDs are a combination of menu number and parameter number, shown in separate fields on the device. See example below.
 - Menus begin with letter "M"
 - Wizards begin with letter "W"
 - Menu levels are separated by a dash (-)
 - Parameter numbers include their respective menu number, and the specific parameter number is prefixed by a period (.)
-



- ① + ② 02-01.01 = Parameter "PV SELECT" (showing current setting of "LEVEL"):
 - the **first parameter** (.01), in the **first menu** "SELECT OUT" (-01),
 under the **second top-level menu** "SETUP" (02)

```
M 02 SETUP
M 02-01 SELECT OUT
02-01.01 PV SELECT
```

Note

Show menu numbers on local display

To view menu numbers on the device, parameter "Service view" must be enabled. (Go to menu "**Setup > Local display**".)

- The item number of the current selection appears in the **info field**.
- The menu number in which the current selection resides, appears on the **title line** (thus no menu numbers appear for top-level menu items, such as "QUICK START", "SETUP", etc.).

Refer to full device menu that follows.

Note

Parameter visibility on device

All available device menus and parameters are included in the following HMI menu structure, each with its own identifying number. The menu/parameter number shown in the HMI menu structure will match the menu/parameter number that appears on the device. However, note that some menus and parameters are only visible on the device based on configuration settings.

- M 01 QUICK START
 - W 01-01 COMMISSION
 - .01 OPERATION
 - .02 MATERIAL TYP
 - .03 UNITS
 - .04 VESSEL SHAPE
 - .05 VESSEL DIM A
 - .06 VESSEL DIM L
 - .07 PRIM MEASDEV
 - .08 METHD FLCALC
 - .09 FLO EXPONENT
 - .10 K FACTOR
 - .11 V NOTCH ANGL
 - .12 SLOPE
 - .13 ROUGHNSSCOEF
 - .14 OCM DIMENS 1
 - .15 OCM DIMENS 2
 - .16 OCM DIMENS 3
 - .17 OCM DIMENS 4
 - .18 LOWER CAL PT
 - .19 UPPER CAL PT
 - .20 RESP RATE
 - .21 VOL UNITS
 - .22 VFLOW UNITS
 - .23 UPPER RANGE (Volume)
 - .24 UPPER RANGE (Volume flow)
 - .25 UPPER RANGE (Custom)
 - .26 CONFIRM
 - W 01-02 AFES
 - .01 AFES RANGE
 - .02 CONFIRM
- M 02 SETUP
 - M 02-01 SELECT OUT
 - 02-01.01 PV SELECT
 - 02-01.02 SV SELECT
 - 02-01.03 LINEARIZTYPE
 - M 02-02 SENSOR
 - 02-02.01 UNITS
 - 02-02.02 FILL RATE
 - 02-02.03 EMPTY RATE
 - M 02-03 CALIBRATION
 - W 02-03.01 AUTO SND VEL
 - .01 ACTUAL DIST
 - .02 CONFIRM
 - W 02-03.02 SENSR OFFSET
 - .01 ACTUAL DIST
 - .02 CONFIRM
 - 02-03.03 LOWER CAL PT
 - 02-03.04 UPPER CAL PT
 - 02-03.05 LOWER LVL PT
 - 02-03.06 UPPER LVL PT
 - 02-03.07 SENSR OFFSET
 - 02-03.08 SOUND VELOC
 - 02-03.09 SND VEL 20°C
 - 02-03.10 SHRTSHOT FRQ
 - 02-03.11 LONGSHOT FRQ
 - 02-03.12 LOWLVLCUTOFF
 - M 02-04 CURRENT OUT
 - 02-04.01 LOOP CUR MDE
 - 02-04.02 MULTIDROP CUR
 - 02-04.03 DAMPING
 - 02-04.04 LOWER RANGE
 - 02-04.05 UPPER RANGE
 - 02-04.06 SATURAT LOW
 - 02-04.07 SATURAT HIGH
 - 02-04.08 LO FAULT CUR
 - 02-04.09 UP FAULT CUR
 - 02-04.10 FAULT CUR
 - 02-04.11 FAILSAFE LOE
 - 02-04.12 LOE TIMER
 - M 02-05 VOLUME
 - 02-05.01 VESSEL SHAPE
 - 02-05.02 VESSEL DIM A
 - 02-05.03 VESSEL DIM L
 - 02-05.04 VOL UNITS
 - 02-05.05 UPPER SCALNG

- M 02-06 VOLUME FLOW
 - 02-06.01 PRIM MEASDEV
 - 02-06.02 METHD FLCALC
 - 02-06.03 VFLOW UNITS
 - 02-06.04 UPPER SCALNG
 - M 02-06-05 PMD DIMS
 - 02-06-05.01 FLO EXPONENT
 - 02-06-05.02 K FACTOR
 - 02-06-05.03 V NOTCH ANGL
 - 02-06-05.04 SLOPE
 - 02-06-05.05 ROUGHNSSCOEF
 - 02-06-05.06 OCM DIMENS 1
 - 02-06-05.07 OCM DIMENS 2
 - 02-06-05.08 OCM DIMENS 3
 - 02-06-05.09 OCM DIMENS 4
- M 02-07 CUSTOM
 - 02-07.01 UPPER SCALNG
 - M 02-07.02 CUSTOM CURVE
 - 02-07-02.01 X VALUE 1
 - 02-07-02.02 Y VALUE 1
 - 02-07-02.03 X VALUE 2
 - 02-07-02.04 Y VALUE 2
 -
 - 02-07-02.63 X VALUE 32
 - 02-07-02.64 Y VALUE 32
- M 02-08 LOCL DISPLAY
 - 02-08.01 START VIEW
 - 02-08.02 SERVICE VIEW
 - W 02-08.03 DISPLAY TEST
- M 03 MAINT/DIAGS
 - M 03-01 SIGNAL
 - M 03-01-01 SIG QUALITY
 - 03-01-01.01 SHRTSHOTCONF
 - 03-01-01.02 CONFIDENCE
 - 03-01-01.03 SHRTSHOT STR
 - 03-01-01.04 ECHO SIG STR
 - 03-01-01.05 NOISE AVG
 - 03-01-01.06 NOISE PEAK
 - M 03-01-02 ECHO CONFIG
 - 03-01-02.01 NEAR RANGE
 - 03-01-02.02 FAR RANGE
 - M 03-01-03 ECHO SELECT
 - 03-01-03.01 ALGORITHM
 - 03-01-03.02 SHRTSHOTTHLD
 - 03-01-03.03 ECHO THOLD
 - 03-01-03.04 POS DETECT
 - 03-01-03.05 ECHO MARKER
 - M 03-01-04 FILTERING
 - 03-01-04.01 NRRW FILTER
 - 03-01-04.02 REFORM ECHO
 - 03-01-04.03 GAIN CONTROL
 - 03-01-04.04 GAINLO THOLD
 - 03-01-04.05 GAINUP THOLD
 - 03-01-04.06 SNSR DAMPING
 - M 03-01-05 SAMPLING
 - 03-01-05.01 ECHO LOCK
 - 03-01-05.02 ECHOLOCK WIN
 - 03-01-05.03 NUM SHRTSHOT
 - 03-01-05.04 NUM LONGSHOT
 - 03-01-05.05 SHRTSHOT DUR
 - 03-01-05.06 LONGSHOT DUR
 - M 03-01-06 TVT CONFIG
 - 03-01-06.01 HOVER LEVEL
 - 03-01-06.02 AFES
 - 03-01-06.03 AFES RANGE
- M 03-02 PEAK VALUES
 - 03-02.01 MIN PV
 - 03-02.02 MAX PV
 - 03-02.03 MIN DISTANCE
 - 03-02.04 MAX DISTANCE
 - 03-02.05 MIN SENS TMP
 - 03-02.06 MAX SENS TMP
- M 03-03 LOOP TEST
 - W 03-03.01 LOOP TEST
- M 03-04 RESETS
 - 03-04.01 DEVICE RSTRT
 - 03-04.02 RESET
 - 03-04.03 RESET PEAK
- M 04 COMMUNICATE
 - 04.01 POLLING ADDR
 - 04.02 IDENTIFY
- M 05 SECURITY
 - W 05.01 CHG USER PIN
 - 05.02 RECOVERY ID
 - 05.03 PIN RECOVERY
 - 05.04 USER PIN
 - 05.05 BUTTON LOCK

F

Abbreviations

Short form	Long form	Description	Units
3-A	3-A Sanitary Standards, Inc.		
AFES	Auto False Echo Suppression		
BS-3680	Flow standards from the British Standards Institute		
CE / FM / CSA	Conformité Européene / Factory Mutual / Canadian Standards Association	safety approval	
C _i	Internal capacitance		F
DAC	Digital to Analog Conversion		
dB	Decibel		dB
DCS	Distributed Control System	control room apparatus	
DC	Direct current		
dK	dielectric constant		
DTM	device type manager		
EDD	Electronic Device Description		
EMC	Electromagnetic compatibility		
FDT	Field Device Tool		
HART	Highway Addressable Remote Transducer		
HFC	HART Communication Foundation		
Hz	Hertz		Hz
I _i	Input current		mA
I _o	Output current		mA
IS	Intrinsically Safe	safety approval	
L _i	Internal inductance		mH
LOE	loss of echo		
mH	milliHenry	10 ⁻³	H
μF	microFarad	10 ⁻⁶	F
μs	microsecond	10 ⁻⁶	s
NE	NAMUR "Empfehlung" (recommendation)		
NPS	Nominal Pipe Size		
OCM	Open channel monitoring		
(SIMATIC) PDM	Process device manager		
pF	pico Farads	10 ⁻¹²	F
PLC	Programmable logic controller		
PMD	Primary measuring device		
ppm	parts per million		
PV	Primary Variable	measured value	

Short form	Long form	Description	Units
PVDF	Polyvinylidene fluoride		
SCADA	Supervisory Control and Data Acquisition		
SV	Secondary Variable	equivalent value	
TVT	Time Varying Threshold	sensitivity threshold	
TFM1600 PTFE	Modified PTFE	polytetrafluoroethylene with perfluoropropyl vinyl ether (PPVE) modifier	
U_i	Input voltage		V
U_o	Output voltage		V

Glossary

accuracy

degree of conformity of a measure to a standard or a true value.

acoustic noise

any undesired audible sound.

agitator

mechanical apparatus for mixing or aerating. A device for creating turbulence.

algorithm

a prescribed set of well-defined rules or processes for the solution of a problem in a finite number of steps.

ambient temperature

the temperature of the surrounding air that comes in contact with the enclosure of the device.

Auto false echo suppression

a technique used to adjust the level of a TVT curve to avoid the reading of false echoes.

Auto false echo suppression range

defines the end point of the TVT distance. This is used in conjunction with auto false echo suppression.

beam angle

the angle diametrically subtended by the one-half power limits (-3 dB) of the sound beam.

beam spreading

the divergence of a beam as it travels through a medium.

blanking

a blind zone extending away from the reference point. The device is programmed to ignore this zone.

confidence

describes the quality of an echo. Higher values represent higher quality. Confidence threshold defines the minimum value.

damping

term applied to the performance of a device to denote the manner in which the measurement settles to its steady indication after a change in the value of the level.

decibel (dB)

a unit used to measure the amplitude of signals.

dielectric

a nonconductor of direct electric current.

display cable connector

male four-pin connector within wiring compartment used to connect display cable.

echo

a signal that has been reflected with sufficient magnitude and delay to be perceived in some manner as a signal distinct from that directly transmitted. Echoes are frequently measured in decibels relative to the directly transmitted signal.

echo confidence

the recognition of the validity of the echo. A measure of echo reliability.

echo lock window

a window centered on an echo in order to locate and display the echo's position and true reading. Echoes outside the window are not immediately processed.

echo marker

a marker that points to the processed echo.

echo processing

the process by which the device determines echoes.

echo profile

a graphical display of a processed echo.

echo strength

describes the strength of the selected echo in dB referred to 1 μ V rms.

electrical noise

unwanted electrical signals that produce undesirable effects in the circuits of the control systems in which they occur.

false echo

any echo which is not the echo from the desired target. Generally, false echoes are created by vessel obstructions.

far range

the distance below the zero percent or empty point in a vessel.

frequency

the number of periods occurring per unit time. Frequency may be stated in cycles per second.

HART

Highway Addressable Remote Transducer. An open communication protocol used to address field devices.

Hertz (Hz)

unit of frequency, one cycle per second. 1 Gigahertz (GHz) is equal to 10^9 Hz.

inductance

the property of an electric circuit by virtue of which a varying current induces an electromotive force in that circuit or in a neighboring circuit. The unit is a Henry.

multiple echoes

secondary echoes that appear as double, triple, or quadruple echoes in the distance from the target echo.

near blanking

see Blanking

nozzle

a length of pipe mounted onto a vessel that supports the flange.

parameters

in programming, variables that are given constant values for specific purposes or processes.

pulse

a wave that departs from an initial level for a limited duration of time, and returns to the initial level.

range

distance between a transducer and a target.

repeatability

the closeness of agreement among repeated measurements of the same variable under the same conditions.

shot

one transmit pulse or measurement.

speed of sound

the speed at which sound is propagated through some medium under specified conditions.

TVT (time varying threshold)

a time-varying curve that determines the threshold level above which echoes are determined to be valid.

ultrasonic

having a frequency above the human ear's audibility limit: about 20,000 hertz.

Index

A

- Abbreviations and identifications list, 249
- Algorithm, 189
- Application example
 - level, 71
 - volume flow, 72
- Approvals, 35
 - specifications, 183
- Auto false echo suppression, 190
 - disabled, 139, 191
 - range, 190
- Auto False Echo Suppression
 - TVT Shaper adjustment, 232
 - via PDM, 231

B

- Breakpoints
 - level, 197
 - volume, 197
 - volume flow, 198

C

- Certificates, 18, 243
- Cleaning, 156
- Communication protocol
 - HART communication foundation, 205
 - HART electronic device description, 205
- Compact Operating Instructions, 243
- conduits
 - requirements, 32
- Configuration
 - HART modem, 23
- Custom TVT shaper mode
 - manual adjustment via PDM, 233
- Customer Support, (Refer to Technical Support)

D

- Damping, 193
- Data logging
 - time-based echo profile storage, 232

- Device Description (DD)
 - see EDD, 210
- Dimensions
 - drawing, 185
 - optional flange adaptor, 186
- Disassembly, 30
- Disposal, 160, 160
- Document history, 13
- Documentation, 243

E

- Echo processing, 188
- Echo profile
 - data logging, 232
 - quick access via PDM, 235
 - view via PDM, 231
- Echo profile utilities
 - auto false echo suppression, 235
 - custom TVT breakpoints, 232
- Electronic Device Description (EDD), 209
 - required for PROFIBUS PA, 210
 - updating, 210

F

- Fail-safe, 195
- Firmware revision, 40
- Flange adaptor, 186
- Flume
 - examples, 100
 - Khafagi Venturi, 87
 - Leopold Lagco, 85
 - Parshall, 84
 - rectangular, 88
 - trapezoidal, 90
 - U-flume, 91
- Flumes
 - cut-throat, 86

H

- HART communication foundation
 - downloading the electronic device description (EDD), 205
- HART modem
 - system configuration, 23

Hazardous area
Laws and directives, 18
Qualified personnel, 19
hazardous area installations device nameplate, 35
HMI
activating, 40
menu structure, 245
operating the display, 40
Hotline, (Refer to Support request)

I

Icons, (see Symbol), (see Symbol)
Identifications and abbreviations
list, 249
Instructions and manuals, 243

L

Loss of echo, 195

M

Maintenance, 155
device information symbols, 165
device status symbols, 163
via SIMATIC PDM, 218
Manuals, 243
Modifications
correct usage, 17
improper, 17

N

Near range (blinking), 192

O

Open channel monitoring (OCM)
primary measuring devices, 80
Operating conditions, 182
Operating Instructions, 243
Output
current output, 194
specifications, 181

P

PDM
see SIMATIC PDM, 209
Performance
specifications, 180
Power
source requirements, 31
specification, 179
Primary measuring devices (PMDs), 80
Process values, 187

Q

QR code label, 244
Qualified personnel, 19

R

Reference conditions, 180
Resets
factory, 142
via HMI, 142
Response rate, 193
Restart, 142
Return procedure, 159

S

Scope of delivery, 15
Security
related parameters, 144
Sensor reference point, 50, 55, 111
Service, 243
Service & Support, 243
Internet, 243
SIMATIC PDM
device maintenance parameters, 218
functions and features, 211
menus, 213
overview, 209
parameters, 212
setup, 209
with HART devices, 205
Sound velocity, 196
Support, 243
Support request, 243
Symbol, 165
configuration, 163
device status, 163, 165
diagnostics, 163, 165

- maintenance, 163, 165
- operating mode, 163
- process value, 163

T

- Technical data, 179
- Technical support
 - Partner, 243
- Technical Support, 243
 - Personal contact, 243
- Test certificates, 18

V

- Velocity, 196
- Volume calculation
 - custom calculation, 196
 - example, 78
 - vessel shape, 57, 121
- Volume flow calculation
 - example, 198

W

- Warranty, 16
- Weir
 - example profiles, 101
 - profiles, 83